

# SPORTS/ART

## 2100 Rower Repair Guide



**SPORTS ART INDUSTRIAL CO., LTD.**

SPORTS ART INDUSTRIAL CO., LTD.

【Table of Contents】

**I. Component Placement Illustrations**

**1-1-1. Rower Illustration**

**1-2-1. Electronic Component Placement Illustration-1**

**1-2-2. Electronic Component Placement Illustration-2**

**1-2-3. Electronic Component Placement Illustration-3**

**1-3-1. Display Illustration**

**1-3-2. Display Board Component Placement**

**1-3-3. Drive Board Component Placement**

**1-3-4. Electronic Part Illustration-Others-1**

**1-3-5. Electronic Part Illustration-Others-2**

SPORTS ART INDUSTRIAL CO., LTD.

**【Table of Contents】**

**II. Introduction**

**2-1-1. Display Functions**

**2-1-2. Key and Program Illustration Placement**

**2-1-3. Key Placement and Functions**

**III. Operating Instructions**

**3-1-1. Stroke/Minute; Mode; Level**

**3-1-2. Manual; Set; Interval (1)**

**3-1-3. Interval (2)**

**3-1-4. Program**

**3-1-5. Enter; Reset**

**IV. Block Diagrams**

**4-1-1. Block Diagram**

**【Table of Contents】**

**V. Board Illustrations and Wire Connections**

**5-1-1. Display Board Component Placement - Back**

**5-1-2. Display Board Component Placement - Front**

**5-1-3. Display Board LEDs**

**5-1-4. Display Board Cable Connectors - 1**

**5-1-5. Display Board Cable Connectors - 2**

**5-2-1. Drive Board Component Illustration**

**5-2-2. Drive Board Connector Placement**

**5-2-3. Drive Board Wire Connections**

SPORTS ART INDUSTRIAL CO., LTD.

**【Table of Contents】**

**VI. Error Messages**

**6-1-1. Unit Does Not Turn On**

**6-2-1. No Resistance**

**6-3-1. Key Malfunction**

**6-4-1. Remote Control Malfunction**

**6-5-1. STROKE/MINUTE Does Not Operate**

SPORTS ART INDUSTRIAL CO., LTD.

**【Table of Contents】**

**VII. Test Configurations**

**7-1-1. Drive Board IGBT Test**

**7-2-1. Drive Board VCC Voltage Test**

**7-3-1. Optic Sensor Test**

**7-4-1. Resistance Voltage Test**

**7-5-1. Display Board VCC Voltage Test**

**7-6-1. Transformer Test**

**7-7-1. Magnet Test**

**7-8-1. Remote Transmitter Test**

**VIII. Blowup Diagram and Part Numbers**

**8-1-1. 2100 Blowup Diagram**

**8-1-2. Part Numbers**

**8-1-3. Part Numbers (Cont.)**

**8-1-4. Part Numbers (Cont.)**

# 2100 Rower

## I. Component Placement Illustrations

**SPORTS ART INDUSTRIAL CO., LTD.**

SPORTS ART INDUSTRIAL CO., LTD.

## 2100 Rower Illustration



SPORTS ART INDUSTRIAL CO., LTD.

## 2100 Rower Electronic Component Placement Illustration - 1

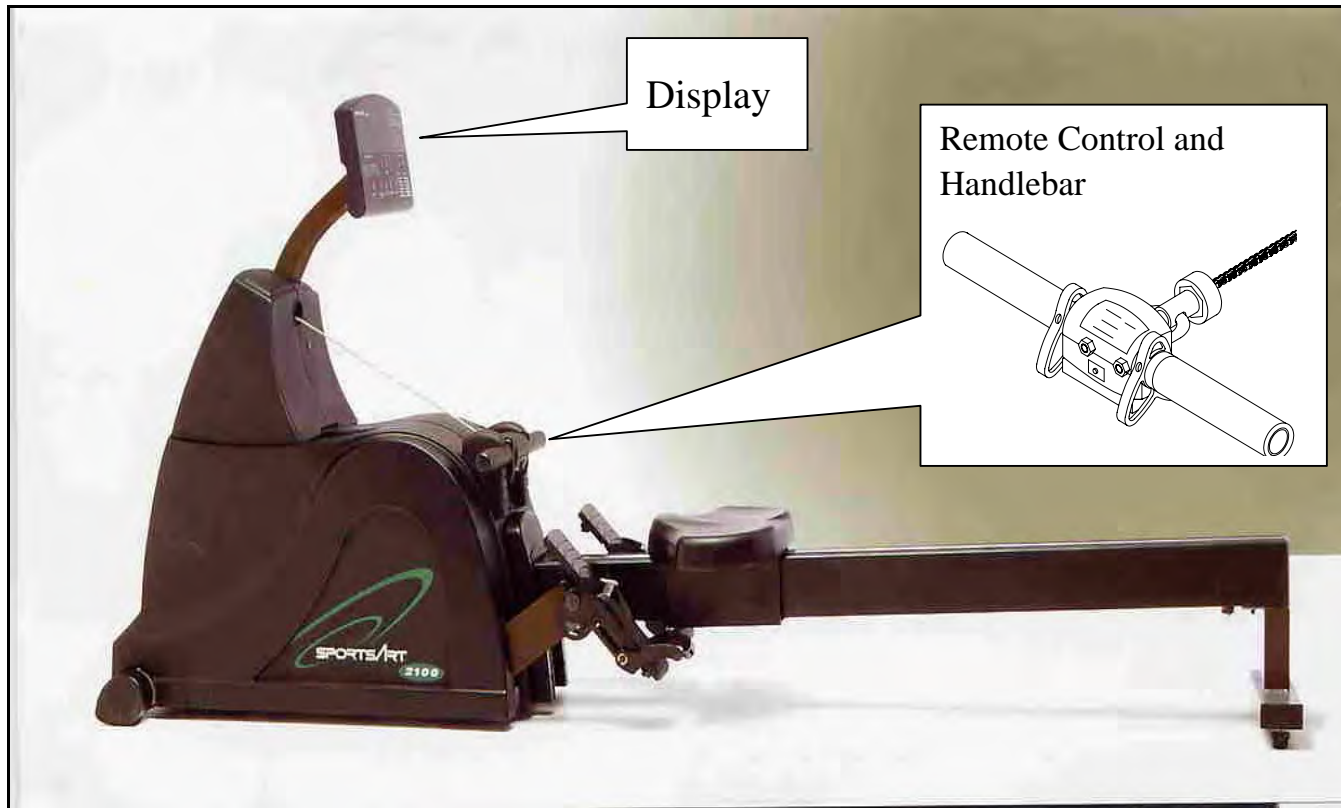

## 2100 Rower Electronic Component Placement Illustration-2

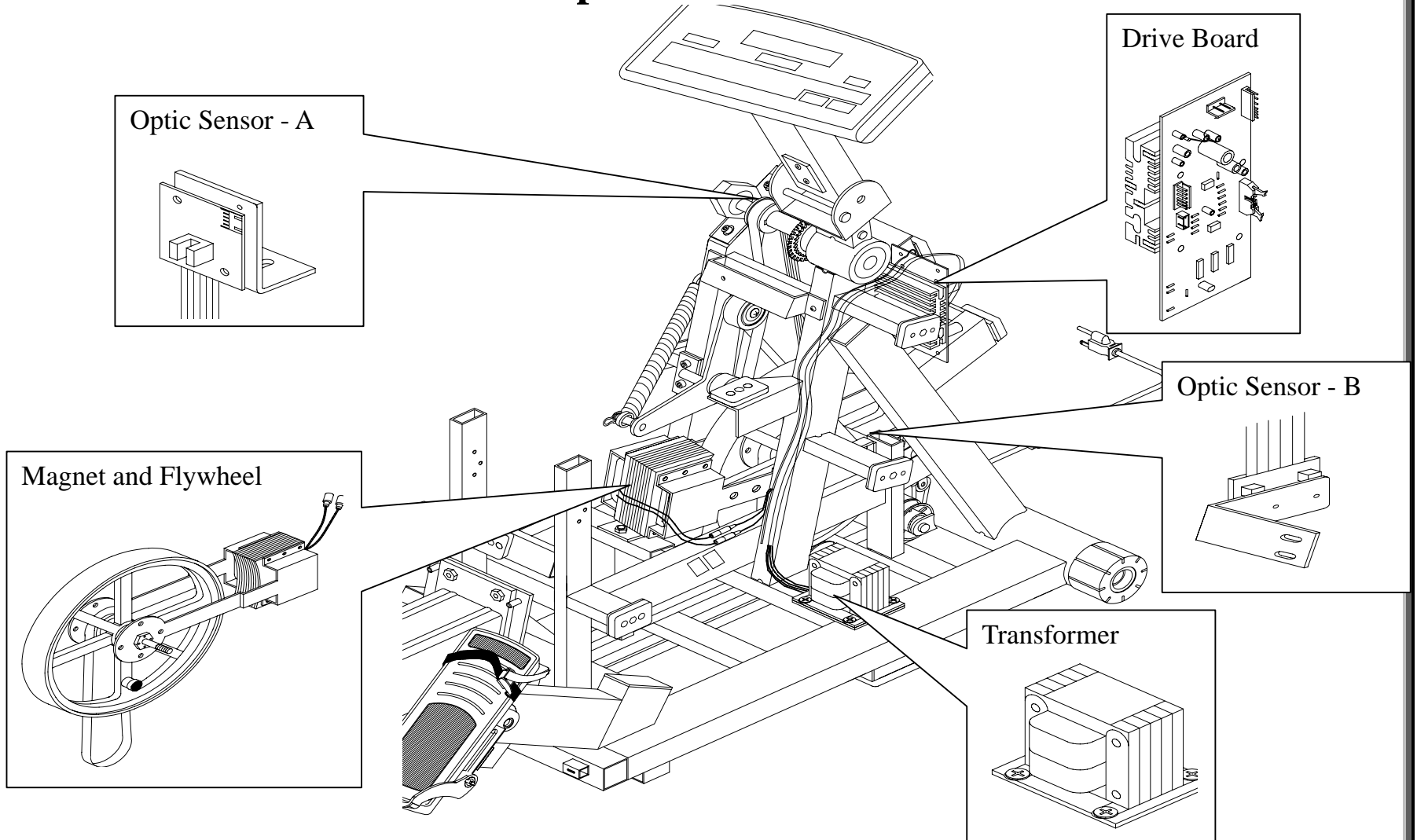

## 2100 Rower Electronic Component Placement Illustration - 3

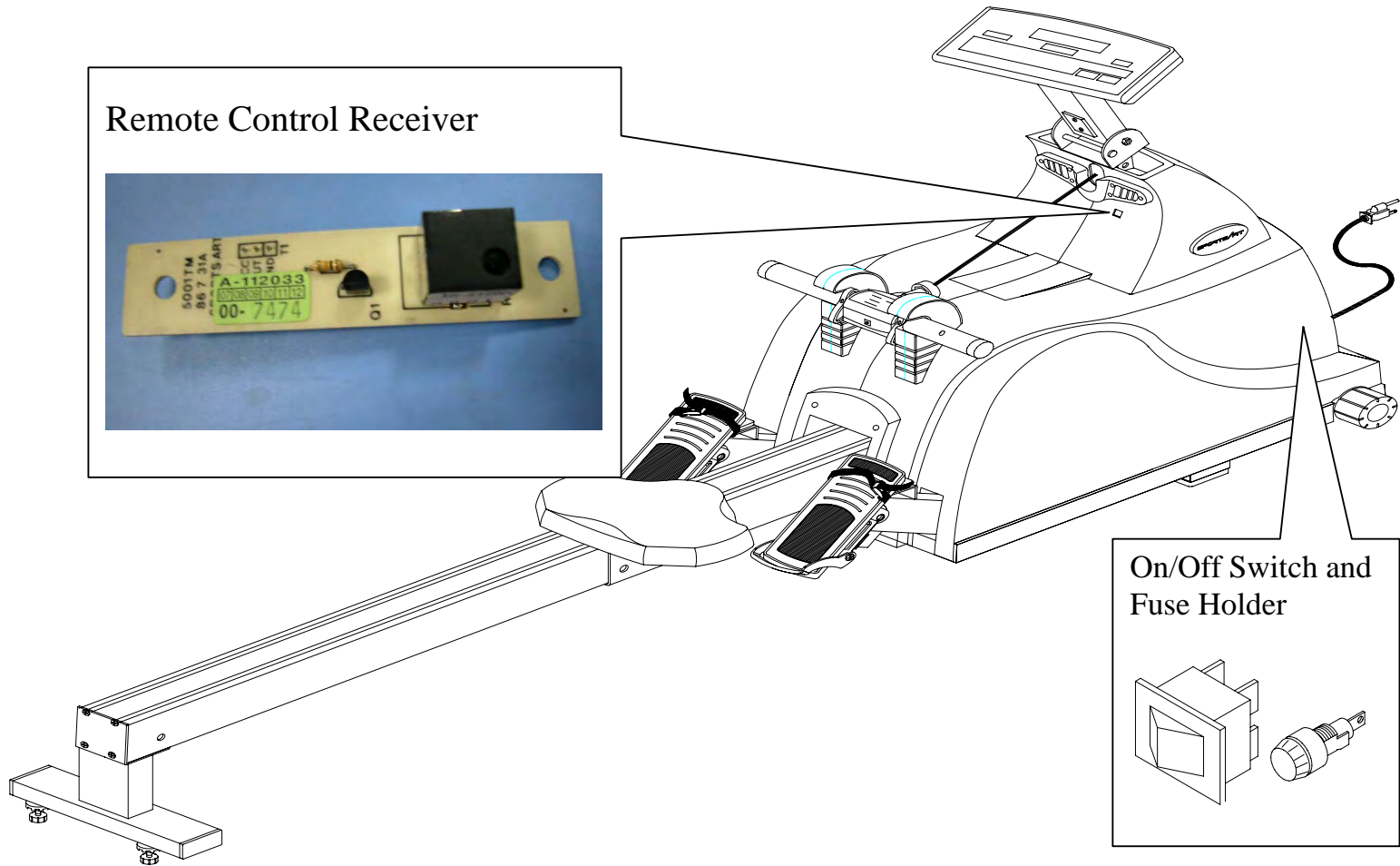

## 2100 Rower Display Illustration

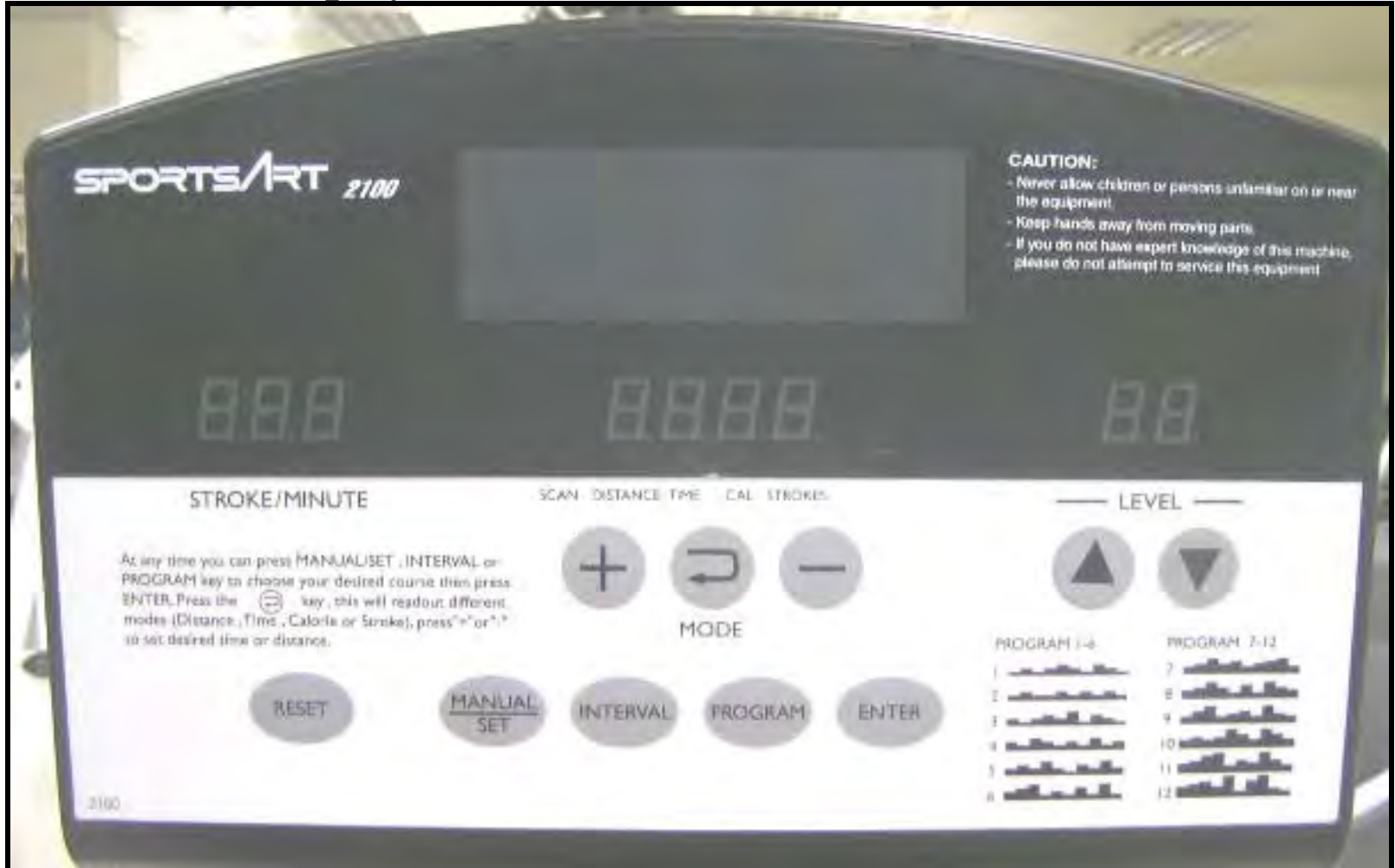

SPORTS ART INDUSTRIAL CO., LTD.

**2100 Rower Display Board Component Placement**

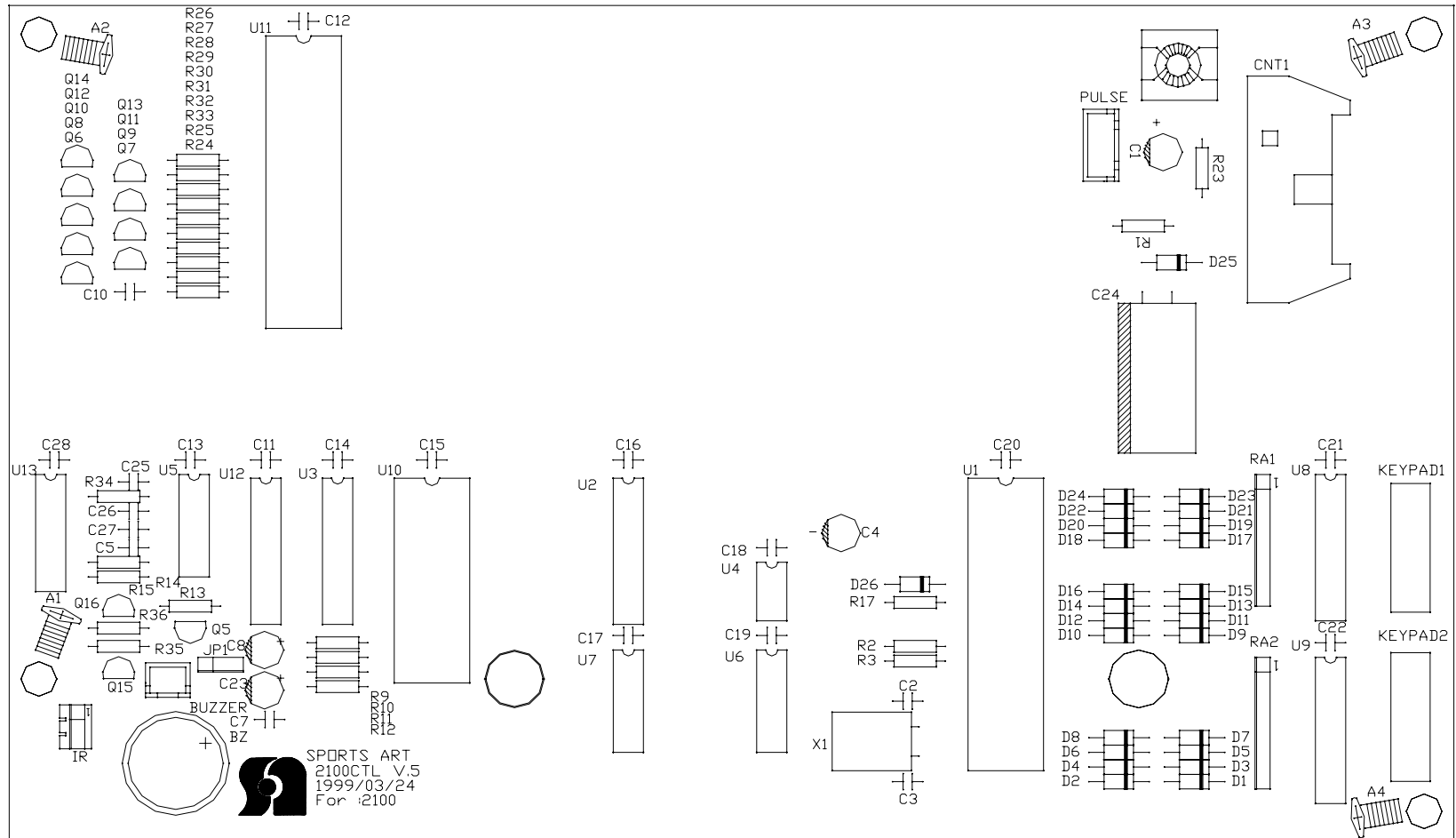

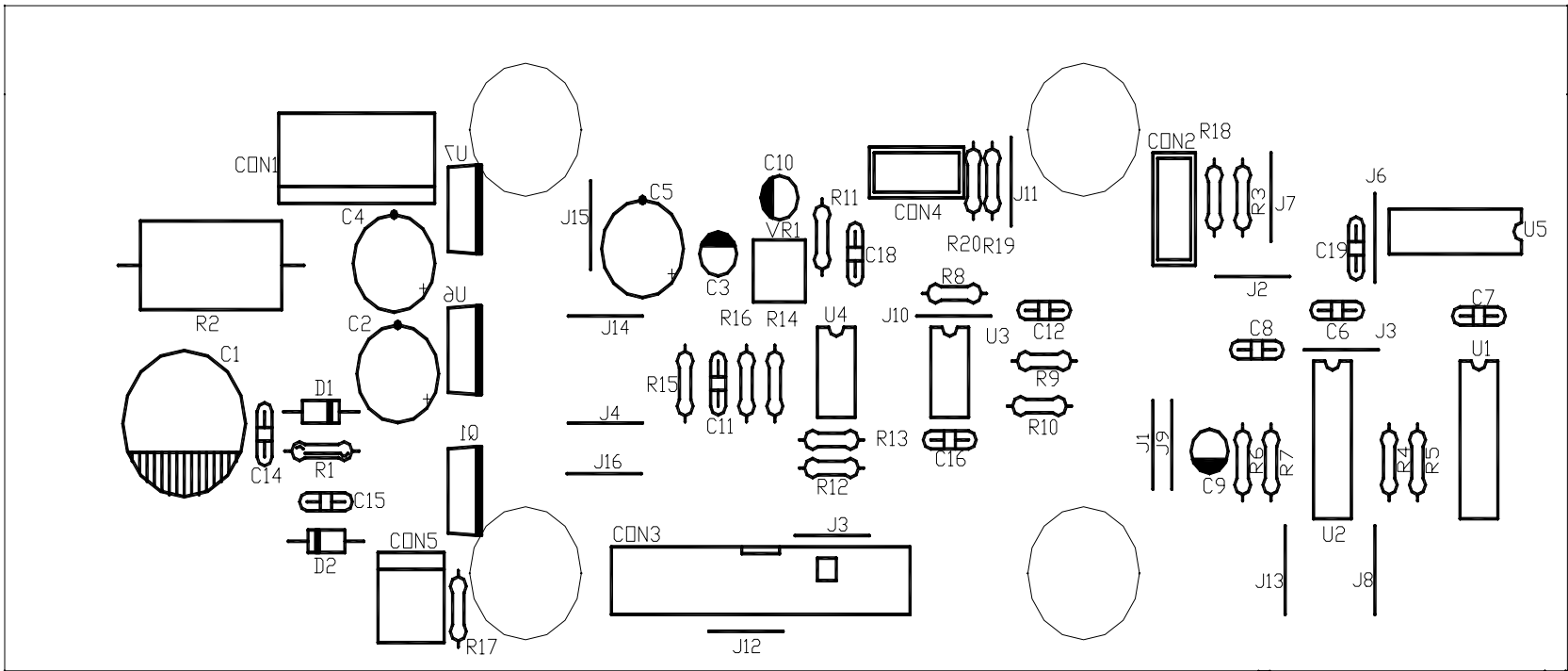

SPORTS ART INDUSTRIAL CO., LTD.

# 2100 Rower Drive Board Component Placement



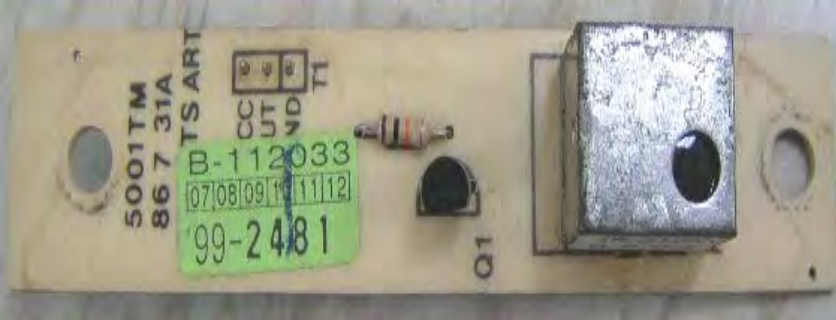

SPORTS ART INDUSTRIAL CO., LTD.

2100 Rower Electronic Part Illustration – Others - 1

Part	Remote Control	Part	Remote Control Receiver
			
Part	Optic Sensor Board – A	Part	Optic Sensor Board - B
			

SPORTS ART INDUSTRIAL CO., LTD.

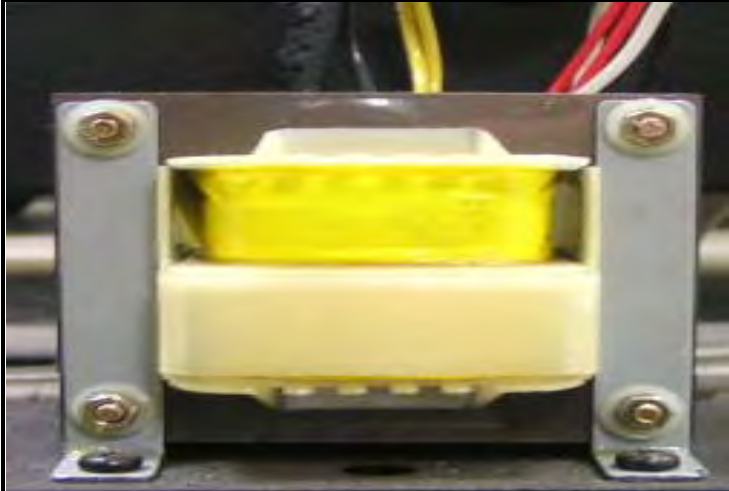
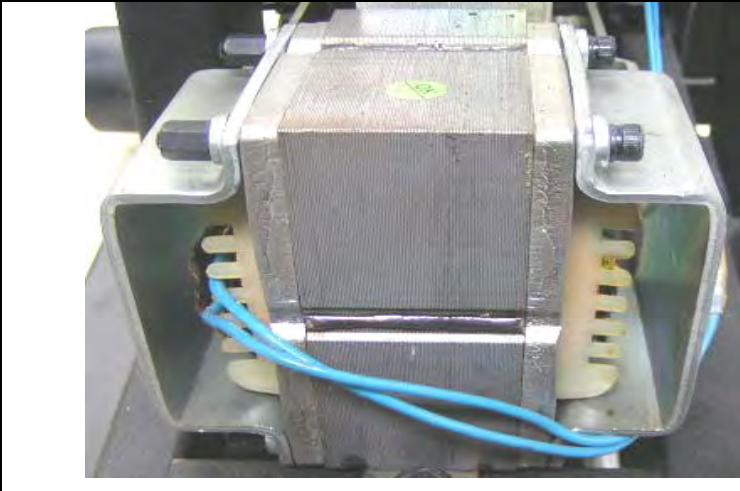
2100 Rower Electronic Part Illustration – Others - 2

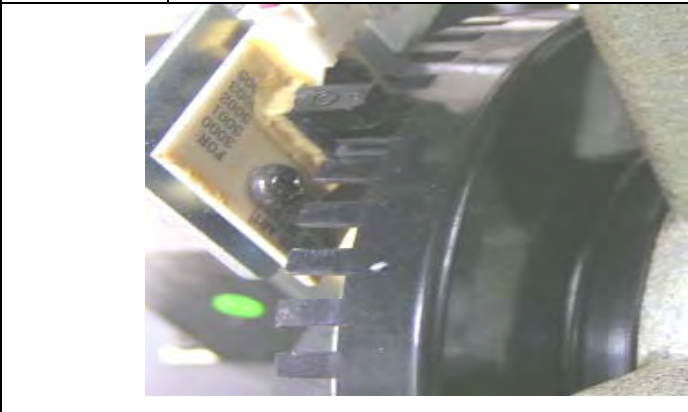
Part	Transformer	Part	Electro-Magnet
 A photograph of a transformer with a yellow primary winding and a white secondary winding, mounted on a metal frame with four screws.		 A photograph of an electro-magnet assembly with a metal core, blue wires, and a green label.	
Part	Optic Sensor Wheel – A (30 Teeth)	Part	Optic Sensor Wheel – B (60 Teeth)
 A close-up photograph of a black gear with 30 teeth, mounted on a metal shaft.		 A close-up photograph of a black gear with 60 teeth, mounted on a metal shaft, with a green light source visible.	

2100 Rower

## II. Introduction

**SPORTS ART INDUSTRIAL CO., LTD.**

## 2100 Rower

### I. Display Functions

#### 1. Windows and Functions

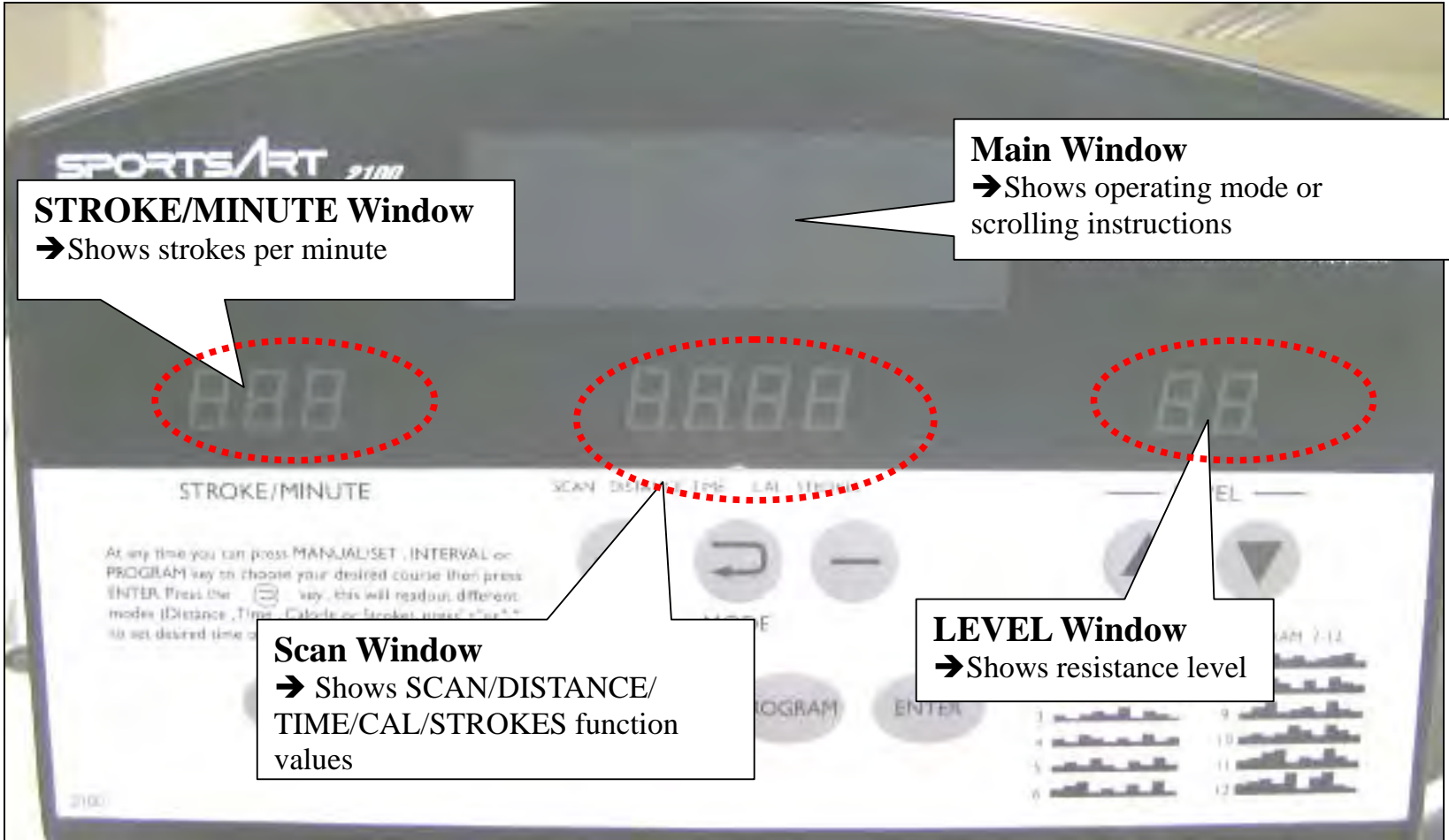

## 2. Key and Program Illustration Placement

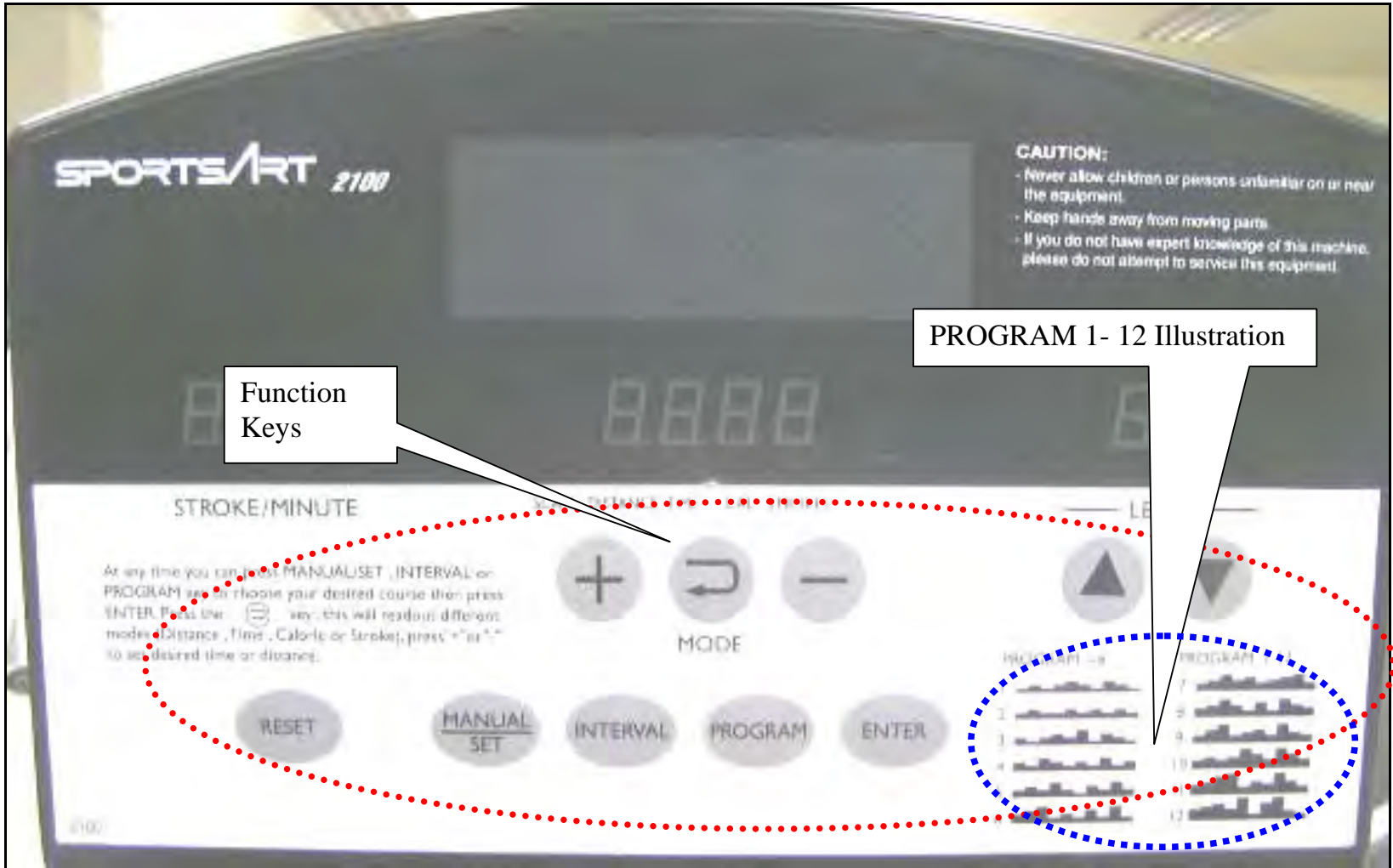

# SPORTS ART INDUSTRIAL CO., LTD.

## 3. Key Placement and Functions

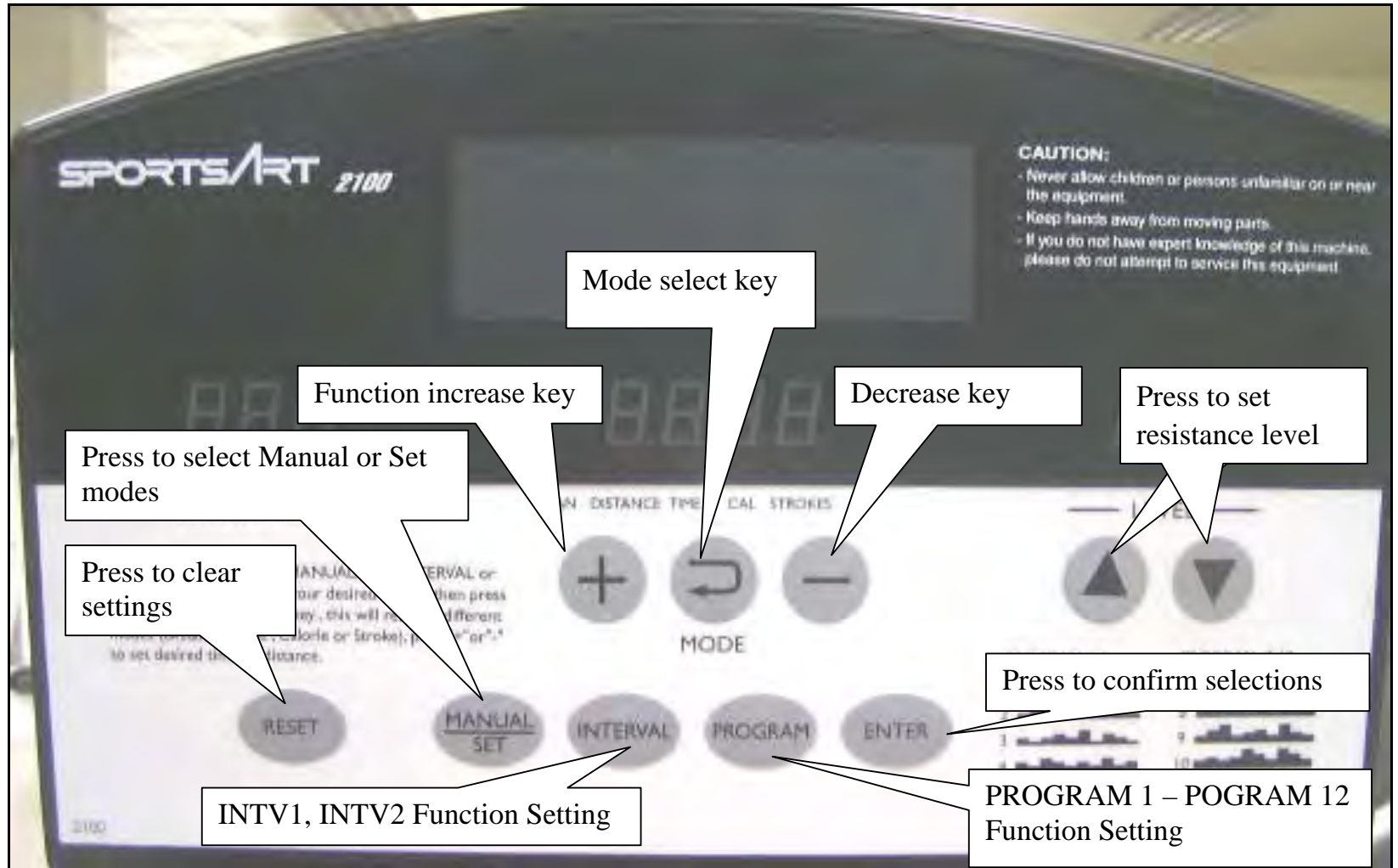

2100 Rower

### III. Operating Instructions

**SPORTS ART INDUSTRIAL CO., LTD.**

## SPORTS ART INDUSTRIAL CO., LTD.

### **1. STROKE/MINUTE Window Function**

Function : 1. Shows the average number of strokes per minute.

Explanation : 1. Strokes per minute changes according to user's stroke speed.

### **2. MODE Window Function**

Function : 1. Shows SCAN/DISTANCE/TIME/CAL/STROKES functions.

Explanation : 1. Press the MODE key until the function you want appears.

Values for that function appear.

Operation : 1. Press the MODE key repetitively to select a function.

2. Press the <▲> or <▼> key to set function values.

### **3. LEVEL Window Function**

Function : 1. Shows the rower resistance.

2. Sets rower resistance.

Explanation : 1. Display controls resistance according to the LEVEL setting.

2. LEVEL value range is from LEVEL 1 – LEVEL 7.

Operation : 1. Press the LEVEL<▲> key until LEVEL 7 appears. Resistance is highest.

2. Press the LEVEL<▼> key until LEVEL 1 appears. Resistance is lowest.

## SPORTS ART INDUSTRIAL CO., LTD.

### 4. MANUAL Function

Function : 1. Sets manual operation. In manual mode, press the function keys for direct control.

Explanation : 1. “MAN’L” on the main window indicates manual mode operation.

2. Directly press keys to operate related functions.

Operation : 1. Press the <MANUAL/SET> key so the main window shows “MAN’L”.

2. Press various keys to directly set related functions.

### 5. SET Function

Function : 1. Determine whether the units appear in metric or American standard mode.

Explanation : 1. When the main window shows “SET”, units can be set to either metric or American standard. For example, speed units would appear as KPH or MPH.

Operation : 1. Press the <MANUAL/SET> key. Display shows “SET”. Press the <ENTER> key to confirm your choice. The display shows “METER” or “FEET”; Press the <UP> or <DOWN> key to make your selection. Press the <ENTER> key to confirm your choice.

### 6. INTERVAL Mode (INTV1)

Function : 1. Provides a user-determined workout under micro-chip memory control.

Explanation : 1. INTV1 has two modes: REST and WORK.

2. In carrying out INTV1, the display automatically alternates between REST and WORK modes.

Operation : 1. Press the <INTV> key. When the display shows “INTV1”, press the < ENTER > key to enter INTV1 mode.

2. Set “REST” and “WORK” modes by pressing <UP>/<DOWN> keys and setting TIME/LEVEL settings. Press <ENTER> to confirm your choice.

## SPORTS ART INDUSTRIAL CO., LTD.

3. The main window shows the following.

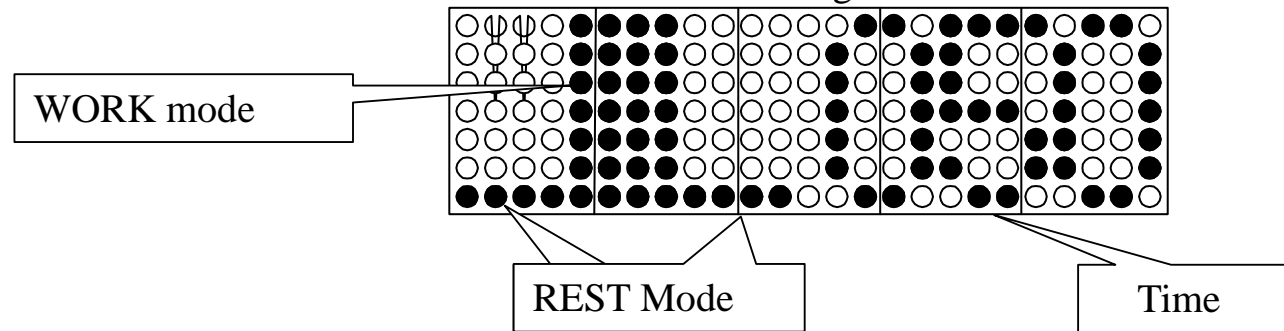

4. Exercise on the unit to start INTV1 operation. When the rest or work segment ends, the REST or WORK flashes on the window.

### 7. INTERVAL Mode (INTV2)

Function : 1. Provides a user determined workout under micro-chip memory function control.

Explanation : 1. INTV2 is made up of eight segments, SEG1-SEG8.

2. The time length and resistance level of each segment can be set.

Operation : 1. Press the <INTV> key to select INTV2. Press the <ENTER> key to confirm your choice.

2. When "SEG1" appears, press the LEVEL and TIME<▲>/<▼> keys to set LEVEL and TIME values. Press the <ENTER> key to confirm your choice. Set other segments in the same way.

3. The window appears as follows.

# SPORTS ART INDUSTRIAL CO., LTD.

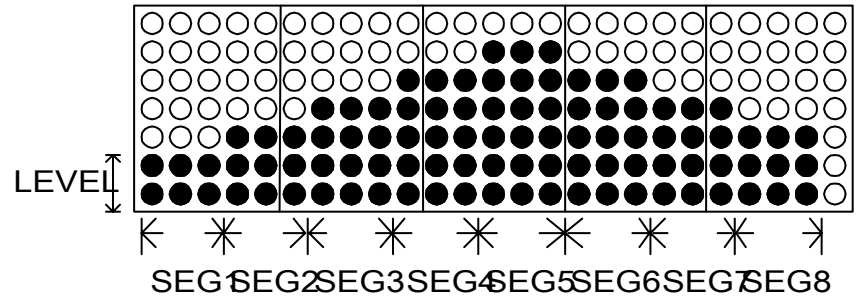

## 8. PROGRAM Function

Function : (1) Press the <PROGRAM> key. The main window shows “PRO 1” through “PRO12”.

Press the <ENTER> key to enter the PROGRAM mode.

(2) In setting the PROGRAM mode, instructions scroll across the unit. Press the <▲>/<▼> keys to set operation in metric or American standard units, “METER” or “FEET”. Press the <ENTER> key to confirm your choice. The main window appears as follows.

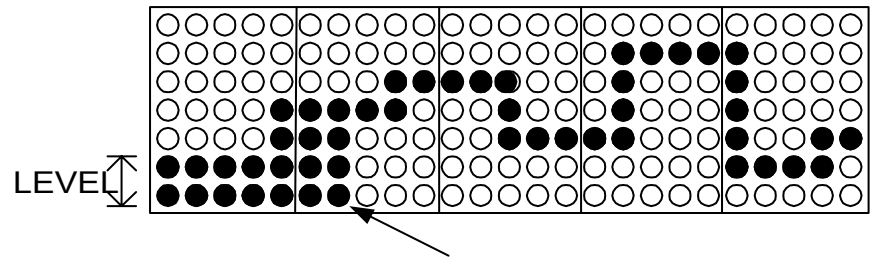

Your location in the exercise program.

(3) In use, press the LEVEL<▲> key. The illustration rises, as shown below.

# SPORTS ART INDUSTRIAL CO., LTD.

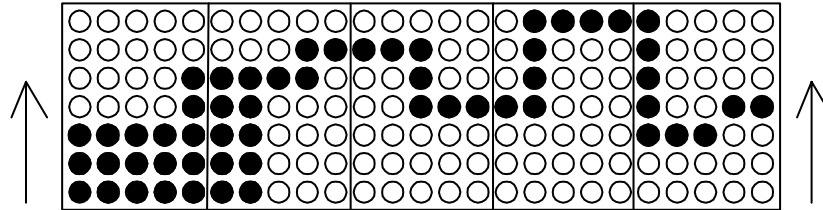

(5) Press the LEVEL <▼> key. The program illustration goes down as shown below.

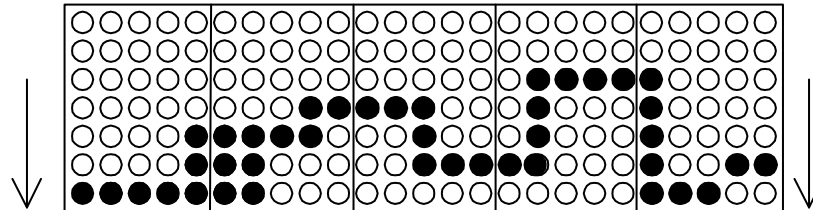

## 9. ENTER Function

Function : 1. Confirms the function command.

Explanation : 1. In setting unit functions, press the <ENTER> key to confirm your selection.

Operation : 1. Press the <ENTER> key. The display beeps once and operates.

## 10. RESET Function

Function : 1. Clears settings, cancels functions.

Explanation : 1. In MANUAL mode, RESET clears all functions.

Operation : 1. In MANUAL mode, press the RESET key. The display STROKE/MINUTE and MODE window clears to “0”.

2. In SET/INTERVAL/PROGRAM modes, press the RESET key to return to the startup

menu.

2100 Rower

## IV. Block Diagrams

**SPORTS ART INDUSTRIAL CO., LTD.**

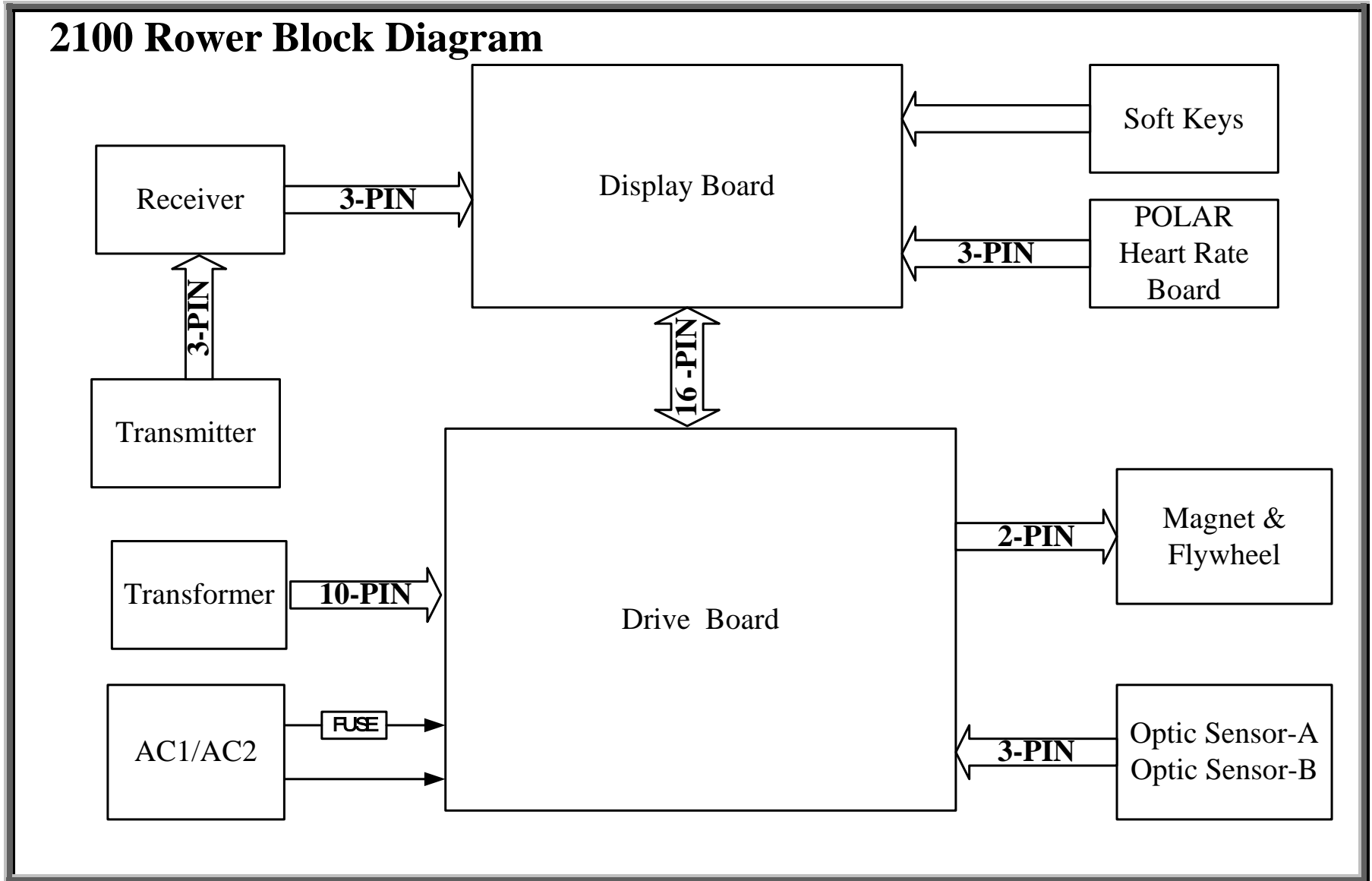

2100 Rower

V. Board Illustrations and Wire Connections

**SPORTS ART INDUSTRIAL CO., LTD.**

SPORTS ART INDUSTRIAL CO., LTD.

**2100 Rower Display Board Component Placement - Back**

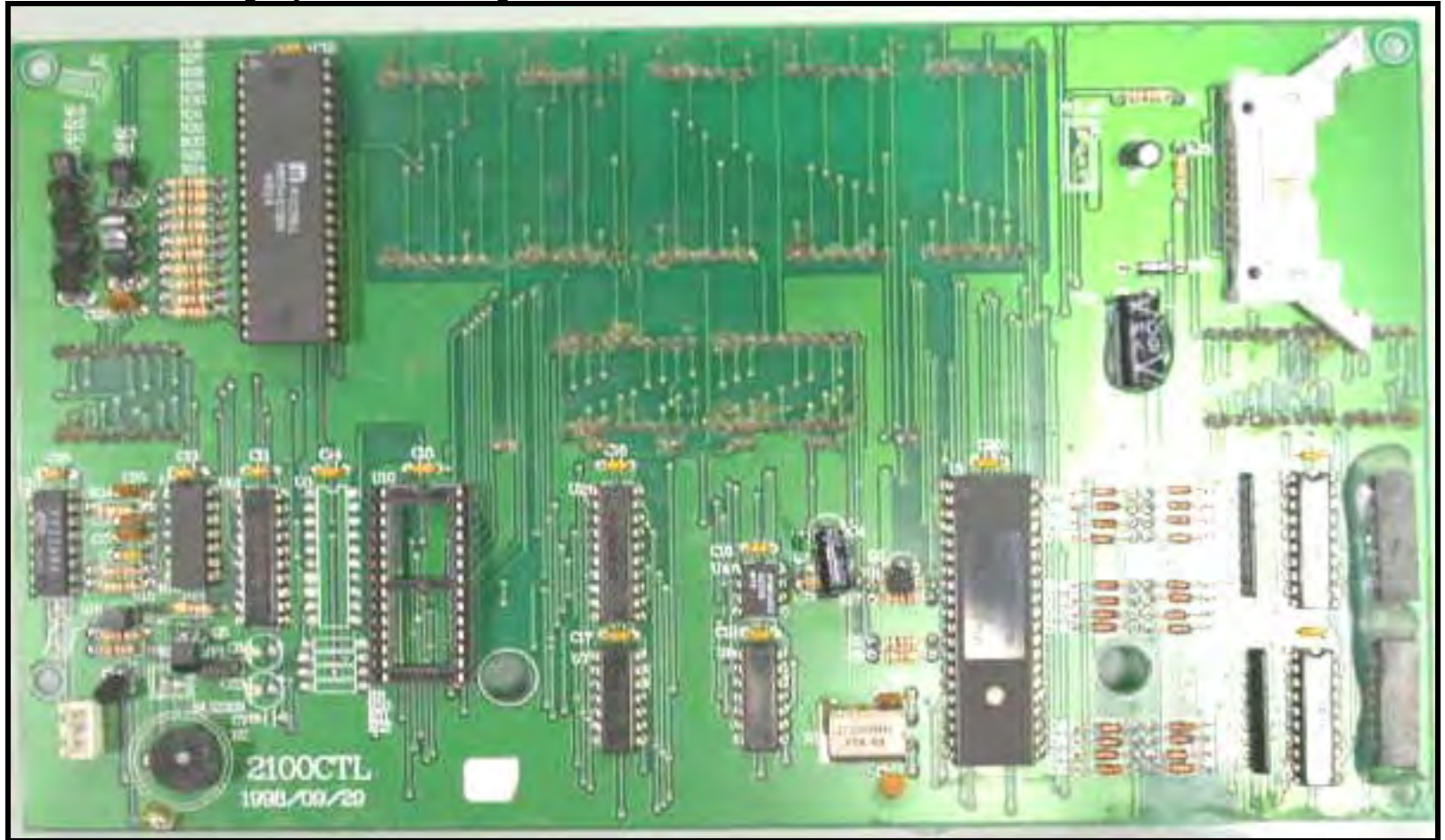

SPORTS ART INDUSTRIAL CO., LTD.

**2100 Rower Display Board Component Placement - Front**

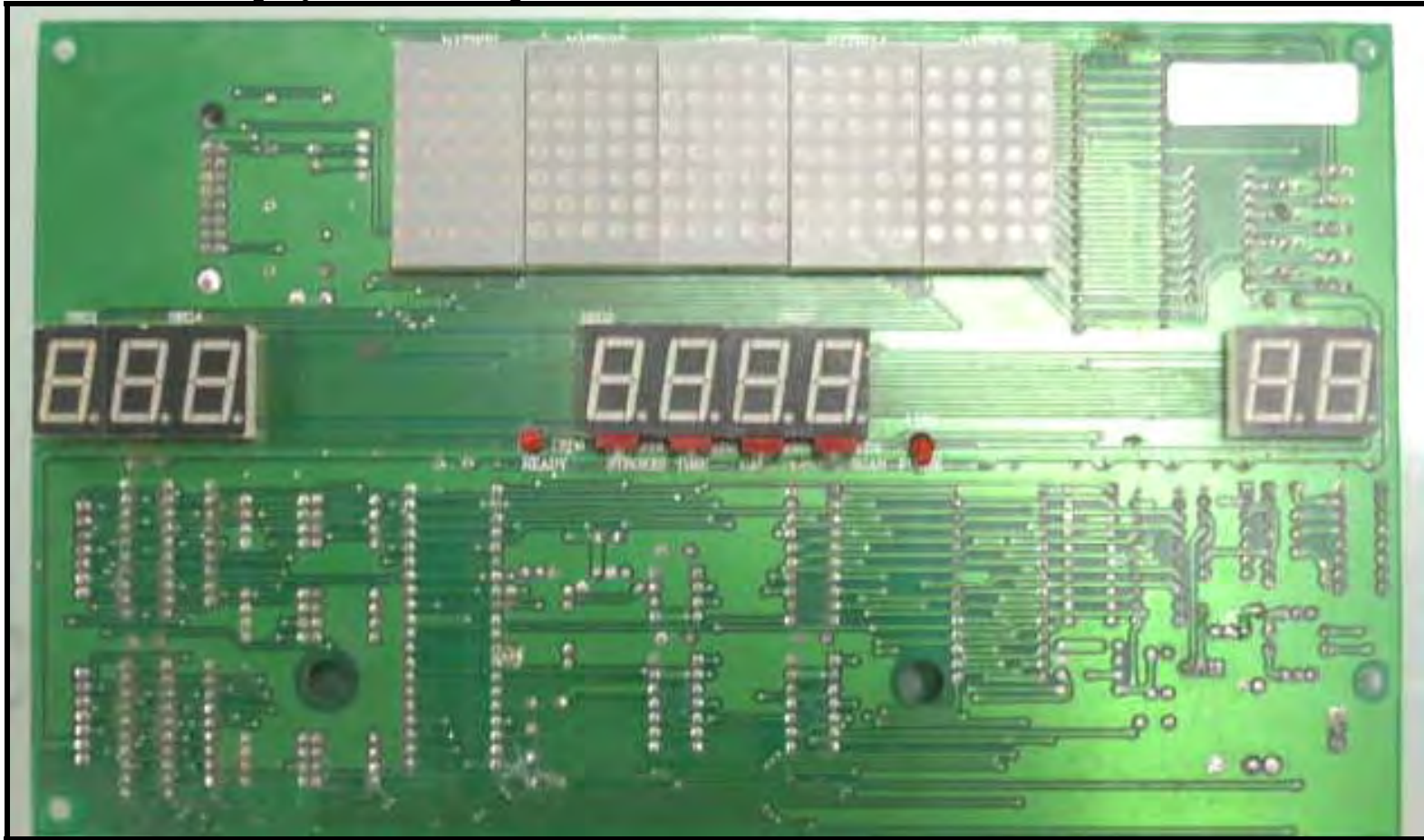

SPORTS ART INDUSTRIAL CO., LTD.

2100 Rower Display Board LEDs

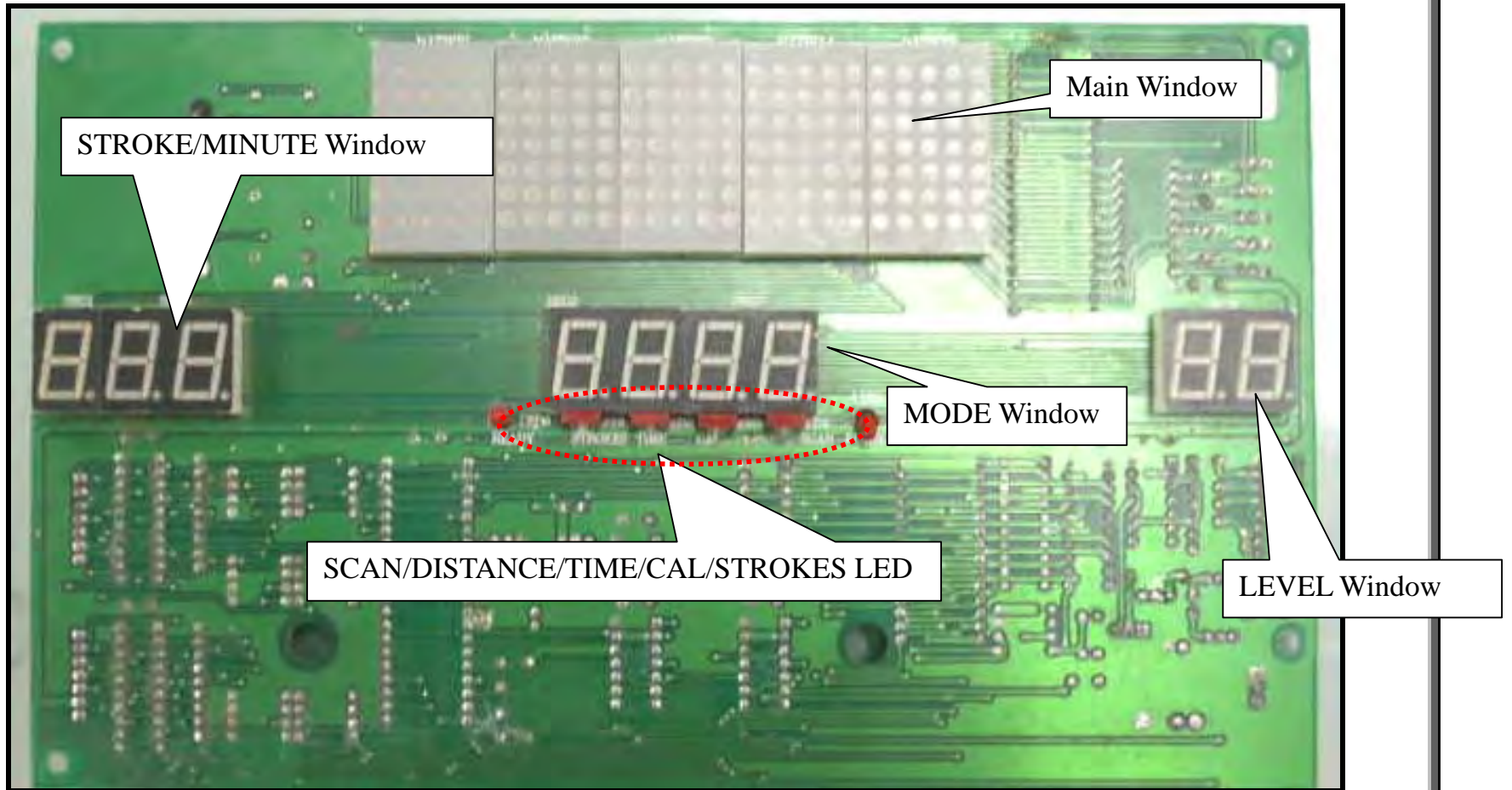

**2100 Rower Display Board Cable Connectors - 1**

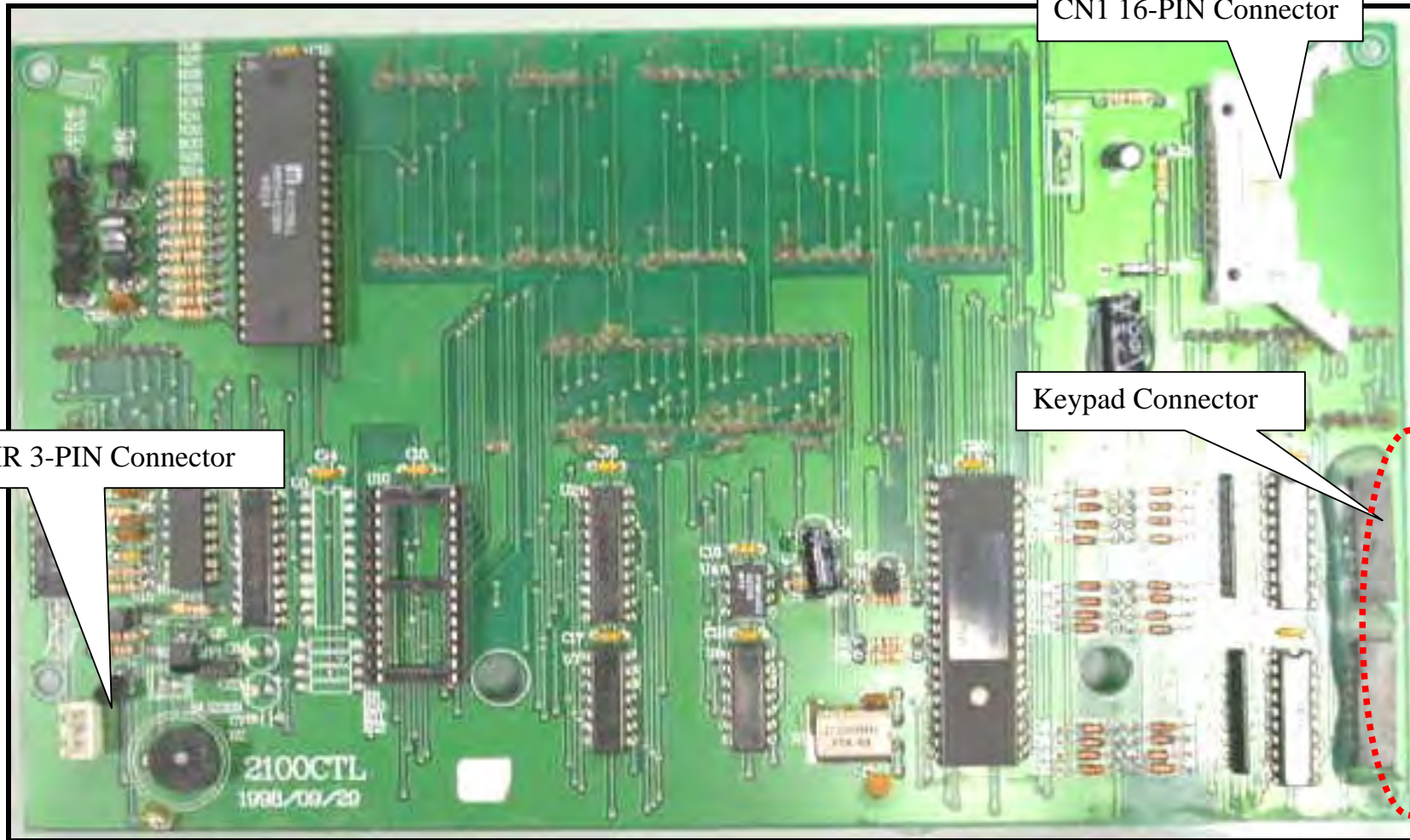

IR 3-PIN Connector

CN1 16-PIN Connector

Keypad Connector

2100 Rower Display Board Cable Connectors - 2

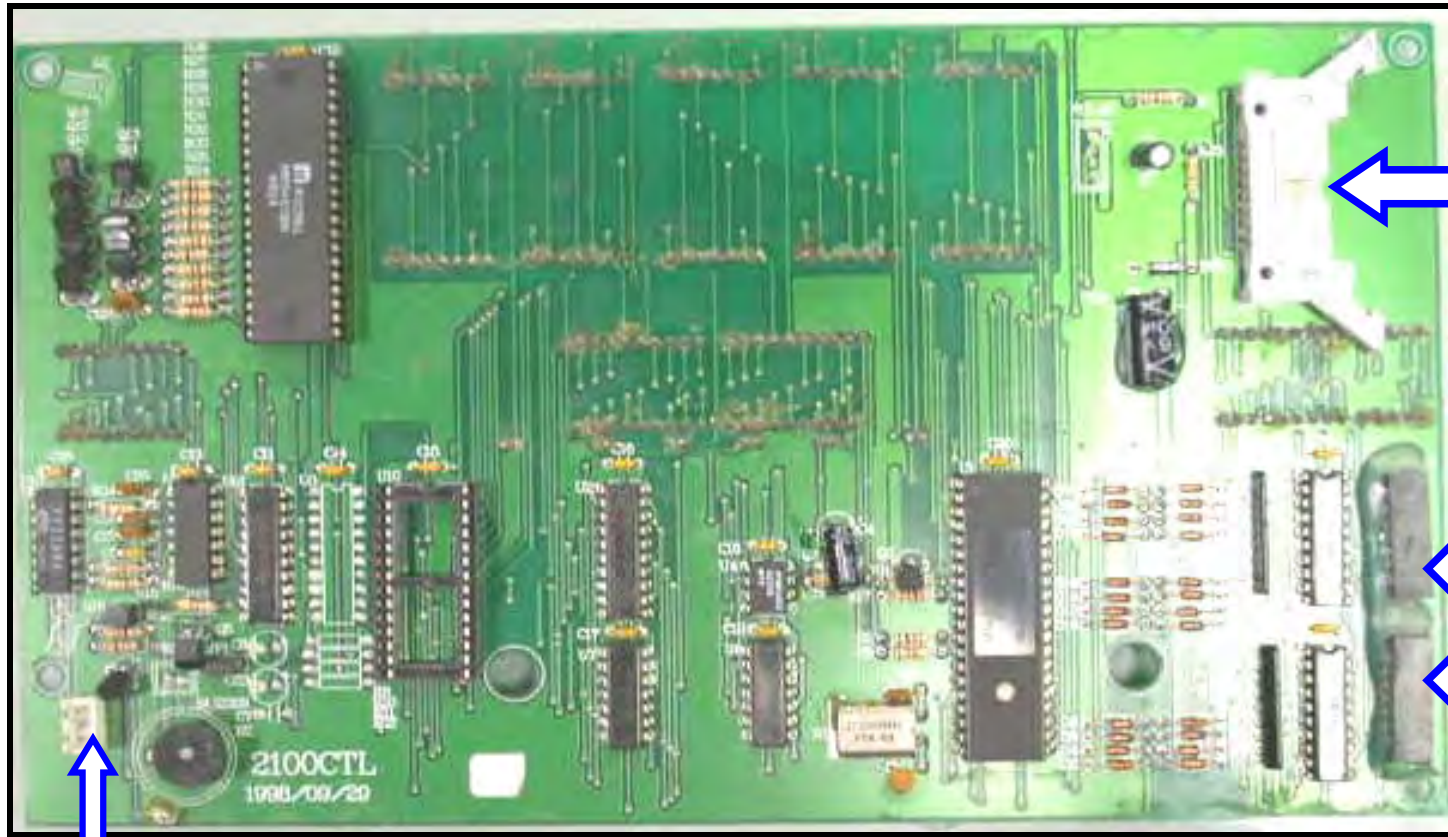

Remote Control

Drive Board

Keys

**2100 Rower Drive Board Component Illustration**

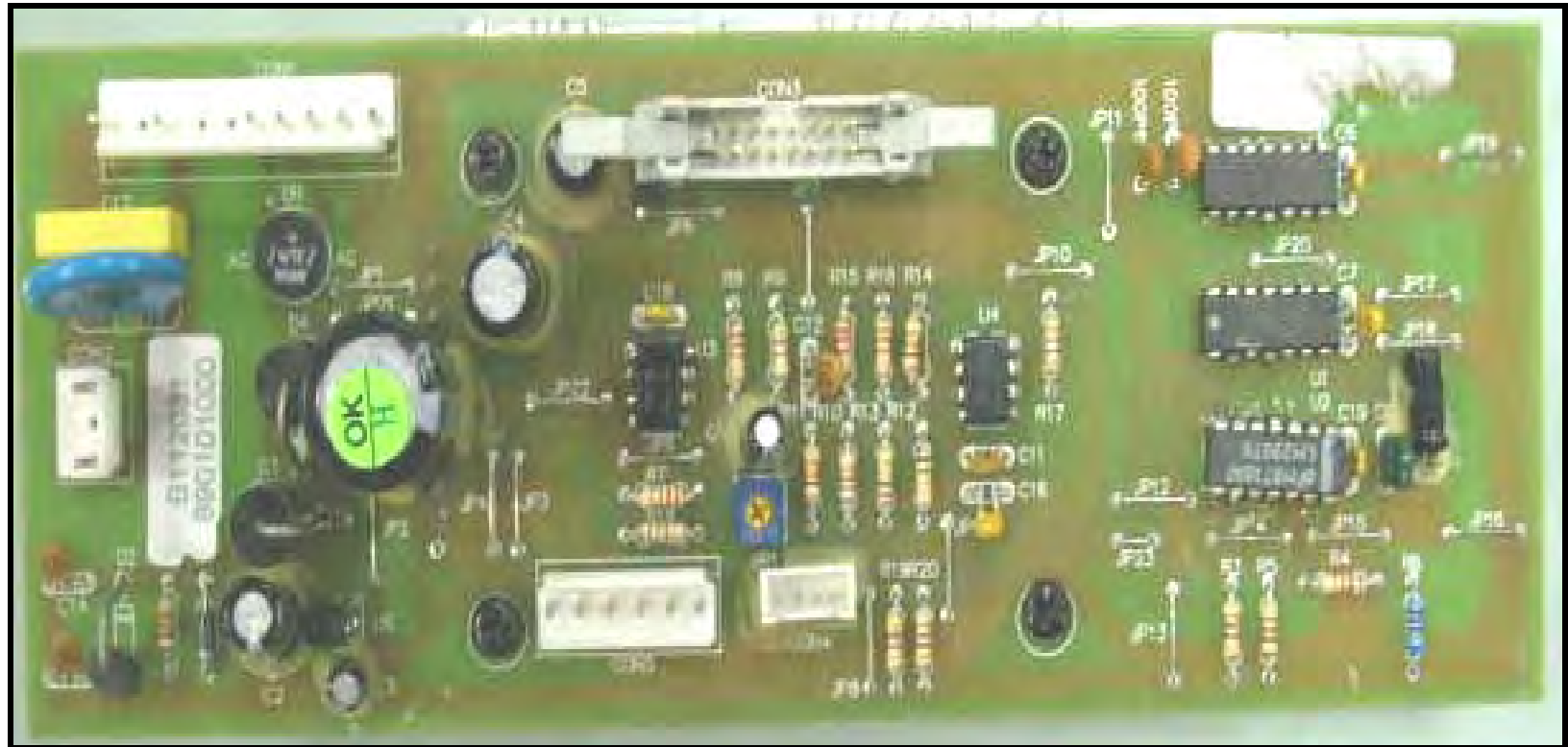

SPORTS ART INDUSTRIAL CO., LTD.

2100 Rower Drive Board Connector Placement

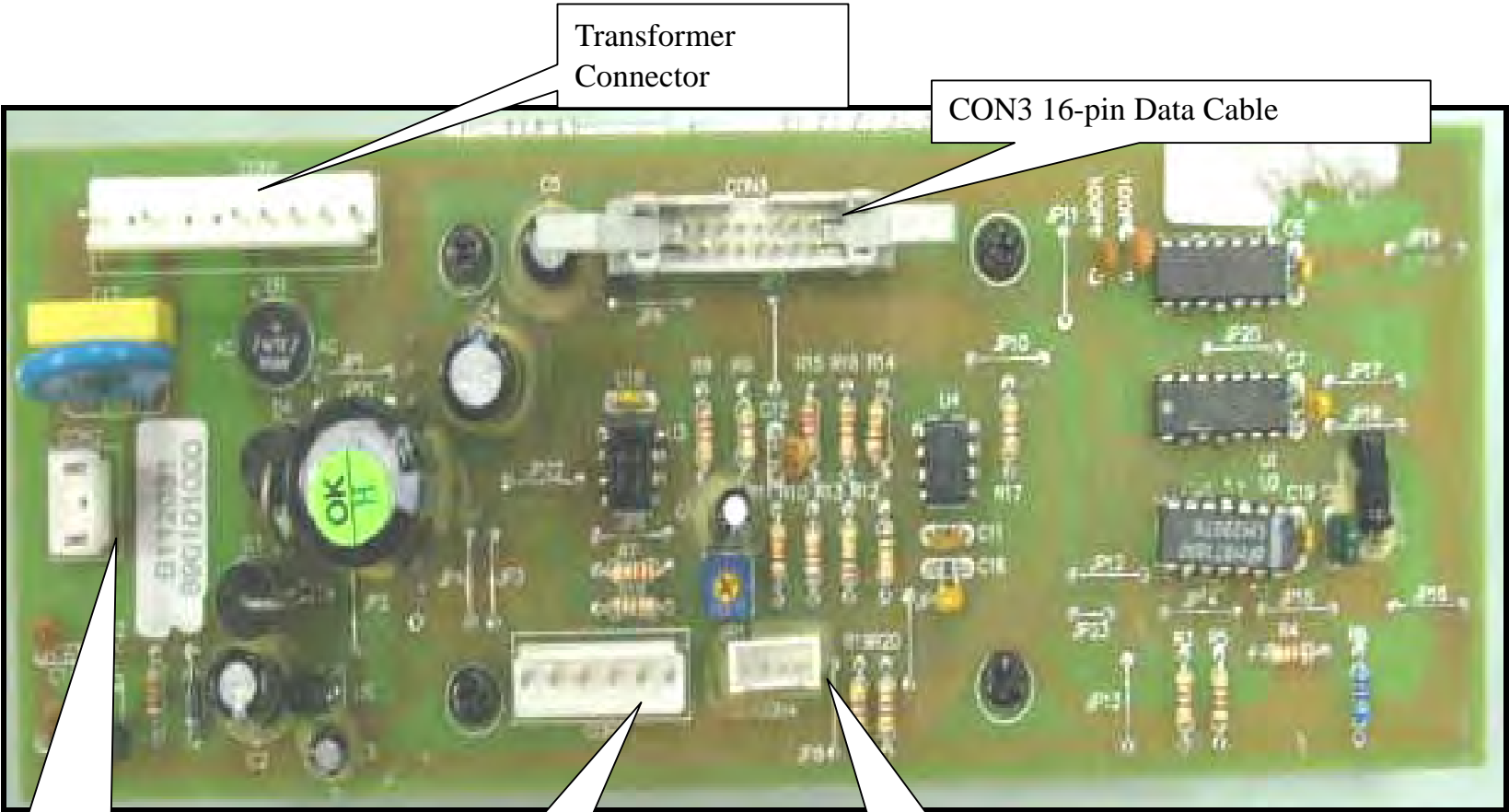

CON2 AC Power Connector

CON5 Magnet / Optic Sensor B

CON4 Optic Sensor A Connector

SPORTS ART INDUSTRIAL CO., LTD.

**2100 Rower Drive Board Wire Connections**

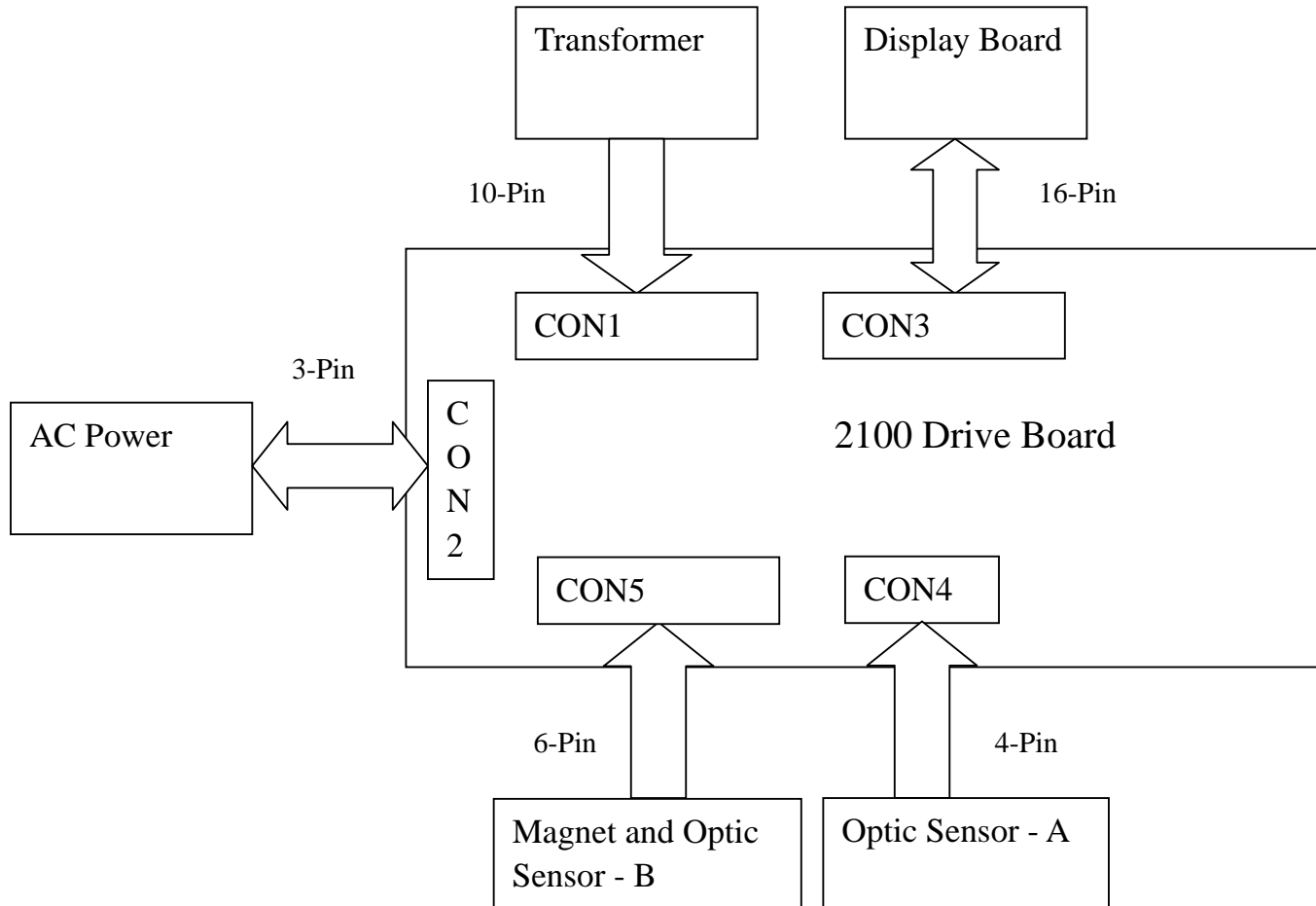

2100 Rower

## VI. Error Messages

**SPORTS ART INDUSTRIAL CO., LTD.**

**2100 Rower Error Message: Press the On/Off Switch; Unit does not light.**

**I. Definition: 1. Turn on unit power. Display does not light.**

**II. Block Diagram**

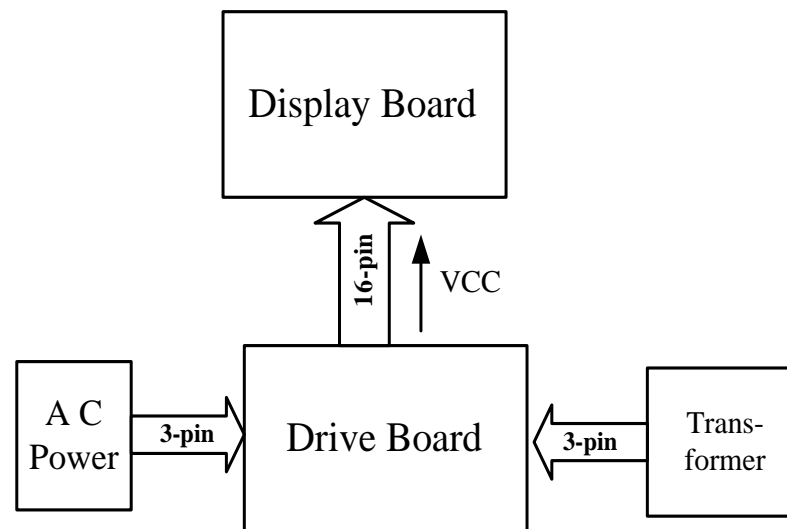

## SPORTS ART INDUSTRIAL CO., LTD.

### III. Operation

Order	Part	Operation
1	On/Off Switch Fuse	1. AC power travels through the on/off switch and fuse to the drive board CON2 connector.
2	Transformer	1. The transformer breaks AC voltage down into small chunks for various functions supplied through the drive board.
3	Drive Board	1. The drive board stabilizes AC voltage and turns it into DC voltage for the display and other components. 2. The drive board sends VCC (DC) voltage to the display.
4	Display Board	1. After receiving VCC voltage, the display lights up. 2. After lighting up, the display windows show values.

### IV. Symptoms of a Malfunction

- (1) After turning on unit power, the display does not light.

### V. Analysis

- (1) Power fuse has blown. Unit will not start.
- (2) Transformer malfunction prevents operation.
- (3) Display did not receive VCC power supply.

SPORTS ART INDUSTRIAL CO., LTD.

**VI. Inspection**

Order	Part	Troubleshooting
1	On/Off Switch	1. Turn on unit power. The On/Off switch should light. 2. Inspect whether the AC power wire is broken or disconnected.
2	Power Fuse	1. Inspect whether the fuse in the exterior fuse holder has blown. 2. Inspect whether the AC power wire is broken or disconnected.
3	Transformer	1. Inspect whether the transformer wires are connected properly. 2. Test whether there is input voltage to and output voltage from the transformer. (See the transformer voltage specifications.)
4	Drive Board	1. Inspect the connection of the AC voltage wire to the drive board. 2. Inspect the connection of the drive board 16-PIN cable. 3. Replace the drive board.
5	Data Cable	1. Inspect the 16-PIN cable connections at the display and drive boards.
6	Display Board	1. Press on the display IC chip. 2. Inspect the wire from the display to the drive board.

## 2100 Error Message: No Resistance

I. Pull the rower handlebar, but there is no resistance.

### II. Block Diagram

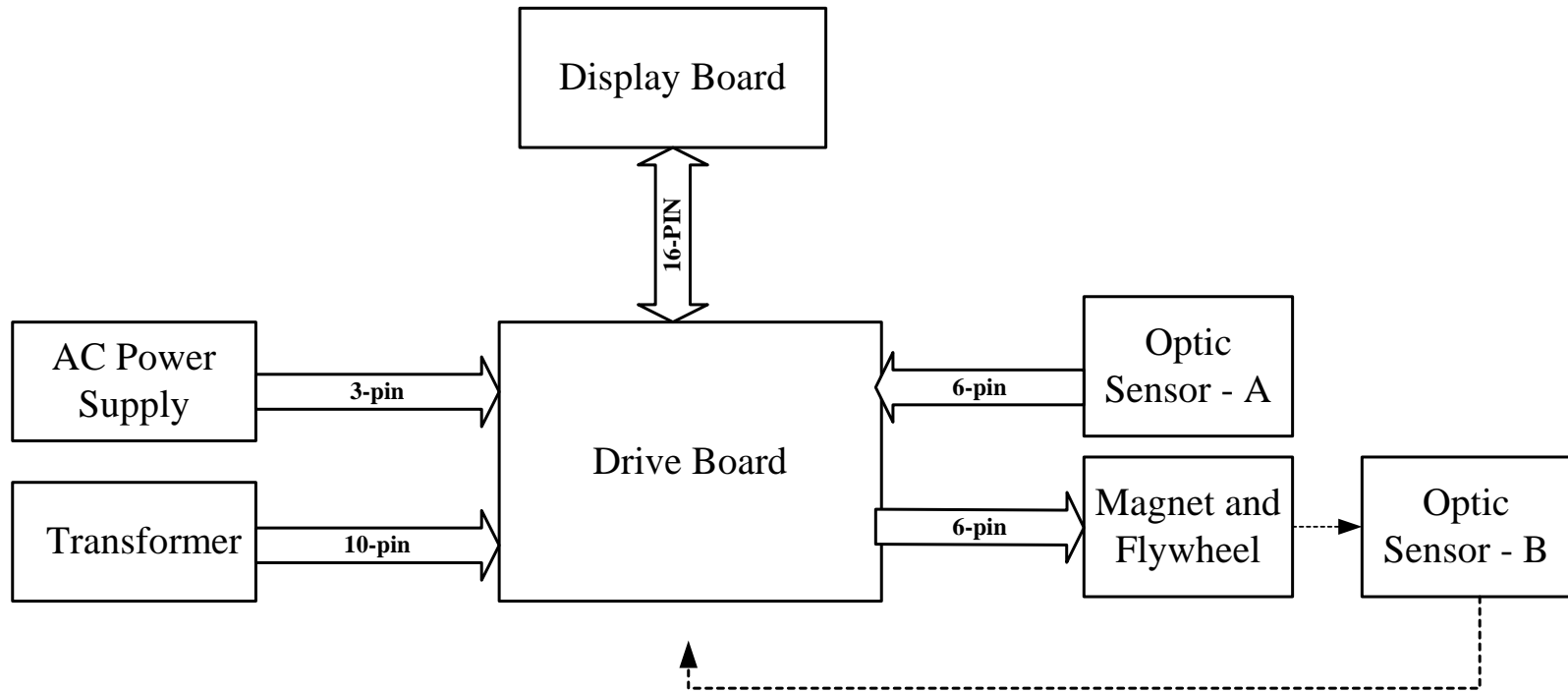

## SPORTS ART INDUSTRIAL CO., LTD.

### III. Operation

Order	Part	Operation
1	Transformer	1. The transformer supplies power for resistance operation.
2	Optic Sensor -A	1. Pulling the handlebar makes the optic sensor wheel move. The sensor detects movement.
3	Optic Sensor - B	1. Flywheel movement makes the optic sensor wheel move. The sensor detects movement.
4	Display Board	1. The CPU reads the optic sensor signals and the speed appears in the RPM window. 2. If there is an optic sensor signal, the display sends the DAC signal to the drive board according to the LEVEL value to control resistance.
5	Drive Board	1. The drive board processes the DAC signal, converting it into voltage for the magnet. 2. The drive board processes optic sensor (B) C signal to accompany the DAC signal, transforming it into voltage which is sent to the magnet to produce resistance. 3. The drive board processes optic sensor (A) and optic sensor (B) signals and then sends them to the display board. 4. The higher the voltage, the stronger the magnetic attraction, the more resistance.
6	Magnet	1. Voltage from the drive board produces magnetic attraction to the flywheel, producing resistance. 2. The higher the voltage, the stronger the magnetic attraction, the more resistance is felt when pulling the handlebar.

### IV. Symptom of a Malfunction

(1) Pull the handle bar of the rower. There is no resistance.

### V. Analysis

(1) The drive board is bad. There is no resistance.

(2) Optic sensor (A) or optic sensor (B) signal does not enter the drive board and display.

(3) Wires are not connected properly.

(4) The magnet is bad. There is no resistance.

SPORTS ART INDUSTRIAL CO., LTD.

**VI. Inspection**

Order	Part	Troubleshooting
1	Display Board	1. Press on the display IC to make sure it is making good contact. 2. Inspect the connections of the data cable from the display to the drive board.
2	Transformer	1. Inspect the transformer wire connection. 2. Inspect output voltage.
3	Optic Sensor-A	1. Inspect whether the teeth on the optic sensor wheel are broken or bent. 2. Inspect the wire connections from the optic sensor to the drive board.
4	Optic Sensor-B	1. Inspect whether the teeth on the optic sensor wheel are broken or bent. 2. Inspect the wire connections from the optic sensor to the drive board.
5	Data Cable	1. Inspect whether the cable connections are secure at the display. 2. Inspect whether cable connections are secure at the drive board. 3. Inspect the connections from the display to the drive board.
6	Drive Board	1. Inspect the drive board wire connections. 2. Inspect IGBTs on the drive board. 3. Replace the drive board.

## 2100 Error Message: Key Malfunction

- I. Definition:**
1. Press any key. The display shows no reaction.
  2. Do not press any key. The display reacts as if a key had been pressed.

### II. Block Diagram

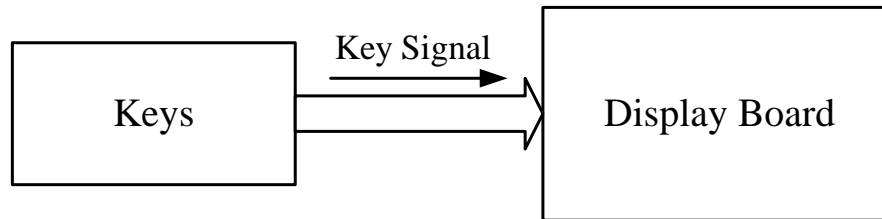

### III. Operation

Order	Part	Operation
1	Keys	1. Press keys on the display. 2. The key signal travels to the display.
2	Display Board	1. The signal is read by the CPU. 2. The CPU carries out key commands according to display settings.

## SPORTS ART INDUSTRIAL CO., LTD.

### IV. Symptom of a Malfunction

(1) Press a key on the display. The display shows no reaction whatsoever.

### V. Analysis

(1) The key has ripped or the key wire connection is bad. The key operation malfunctions.

(2) The display key circuit is bad. The key operation malfunctions.

### VI. Inspection

Order	Part	Troubleshooting
1	Keys	<ol style="list-style-type: none"><li>1. Inspect whether the keys are cracked.</li><li>2. Inspect whether wires are connected properly to the key head.</li><li>3. Replace the keys.</li></ol>
2	Display Board	<ol style="list-style-type: none"><li>1. Inspect whether the keypad connection to the display board is intact.</li><li>2. Press down on the display IC (U8, U9) to make a good connection.</li><li>4. Replace the display resistors RA1 and RA2.</li></ol>

## 2100 Error Message: Remote Control Malfunctions

**I. Definition:** 1. Press the remote control switch repetitively. The display LEVEL window shows no reaction.

2. Do not press the remote control switch. The display LEVEL window changes.

### II. Block Diagram

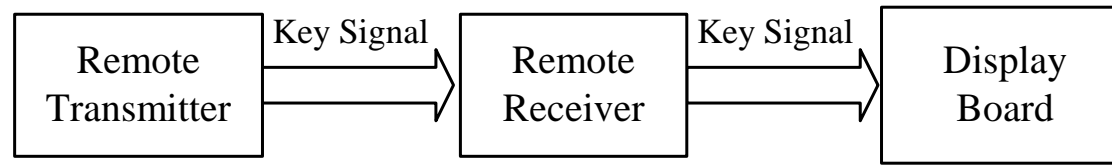

### III. Operation

Order	Part	Operation
1	Remote Transmitter	1. Press the display transmitter switch. 2. The switch signal travels to the remote receiver.
2	Remote Receiver	1. The receiver receives the transmitter signal. 2. The receiver sends the signal to the display board.
3	Display Board	1. The switch signal is sent to the CPU. 2. The CPU processes the signal.

## SPORTS ART INDUSTRIAL CO., LTD.

### IV. Symptom of a Malfunction

(1) Press the remote control switch. The display LEVEL window shows no change.

### V. Analysis

(1) Remote control batteries lack voltage. Or the switch connector is bad.

(2) Remote receiver is bad. Or the connection of the wire from the receiver to the display is bad.

(3) Display malfunction.

### VI. Inspection

Order	Part	Troubleshooting
1	Remote Transmitter	1. Inspect the transmitter batteries for voltage. 2. Inspect the transmitter switch connection. Or replace the switch. 3. Replace the remote transmitter.
2	Remote Receiver	1. Inspect the wire connections from the remote receiver to the display. 2. Replace the remote control receiver.
3	Display Board	1. Inspect the connection of the display IR connector and the remoter receiver. 2. Replace display IC U13(PT2249). 3. Replace display transistors Q15, Q16 (C1815).

## 2100 Rower Error Message: Display STROKE/MINUTE Does Not Operate

- I. Definition:**
1. Optic sensor (A) board does not operate.
  2. Pull the rower handlebar; the **STROKES** value never changes.
  3. Pull the rower handlebar; the **DISTANCE** value never changes.

### II. Block Diagram

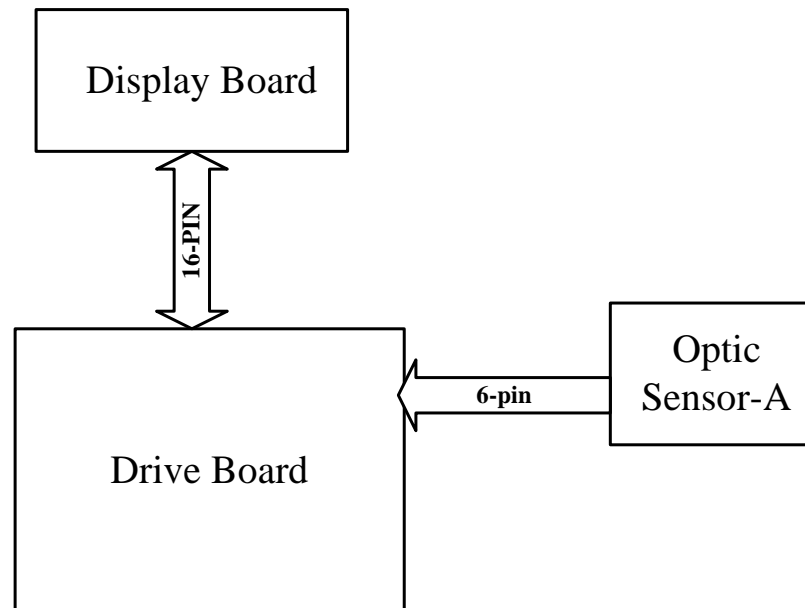

## SPORTS ART INDUSTRIAL CO., LTD.

### III. Operation

Order	Part	Operation
1	Optic Sensor - A	<ol style="list-style-type: none"><li>1. As the user exercises, the optic sensor wheel rotates. Optic sensor (A) board detects wheel movement.</li><li>2. Optic sensor (A) board sends its signal to the drive board. The drive board processes the signal and sends it to the display.</li></ol>
2	Display Board	<ol style="list-style-type: none"><li>1. The CPU reads the optic sensor (A) signal and displays it at the value in the MODE window.</li><li>2. Every time the optic sensor (A) board detects a stroke, the CPU adds one more stroke to the stroke count.</li><li>3. After calculating the signal from optic sensor (A), the CPU shows the DISTANCE value.</li></ol>
3	Drive Board	<ol style="list-style-type: none"><li>1. The drive board supplies VCC voltage to the optic sensor (A).</li><li>2. The drive board converts the optic sensor (A) signal into the MC、C_DIR signal which goes to the display.</li></ol>

### IV. Symptoms of a Malfunction

- (1) Pull the rower handle. The display STROKE/MINUTE window value does not change.
- (2) Pull the rower handle. The display MODE window STROKES count does not increase.
- (3) Pull the rower handle. The display MODE window DISTANCE value does not increase.

### V. Analysis

- (1) Wire from the optic sensor (A) board to the drive board is bad.
- (2) Optic sensor (A) board is bad.
- (3) Data cable from the drive board to the display is bad.
- (4) Optic sensor (A) wheel is bad.
- (5) Drive board is bad.
- (6) Display board is bad.

SPORTS ART INDUSTRIAL CO., LTD.

**VI. Inspection**

Order	Part	Troubleshooting
1	Optic Sensor (A) Board	<ol style="list-style-type: none"> <li>1. Inspect whether the teeth on the optic sensor wheel are broken or bent.</li> <li>2. Inspect the wire connection of the optic sensor (A) board to the drive board. Or replace the wire.</li> <li>3. Replace the optic sensor (A) board.</li> </ol>
2	Data Cable	<ol style="list-style-type: none"> <li>1. Inspect the wire connections on the display.</li> <li>2. Inspect the wire connections on the drive board.</li> <li>3. Inspect the data cable from the display to the drive board. Or replace the cable.</li> </ol>
3	Display Board	<ol style="list-style-type: none"> <li>1. Press down on the display IC chip to make sure that it is seated well.</li> <li>2. Inspect the connections of the data cable from the display to the drive board. Replace the data cable.</li> </ol>
4	Drive Board	<ol style="list-style-type: none"> <li>1. Inspect all connections to the drive board.</li> <li>2. Replace the drive board.</li> </ol>

2100 Rower

## VII. Test Configurations

**SPORTS ART INDUSTRIAL CO., LTD.**

# 2100 Rower Drive Board IGBT Test

## I. Test Configuration

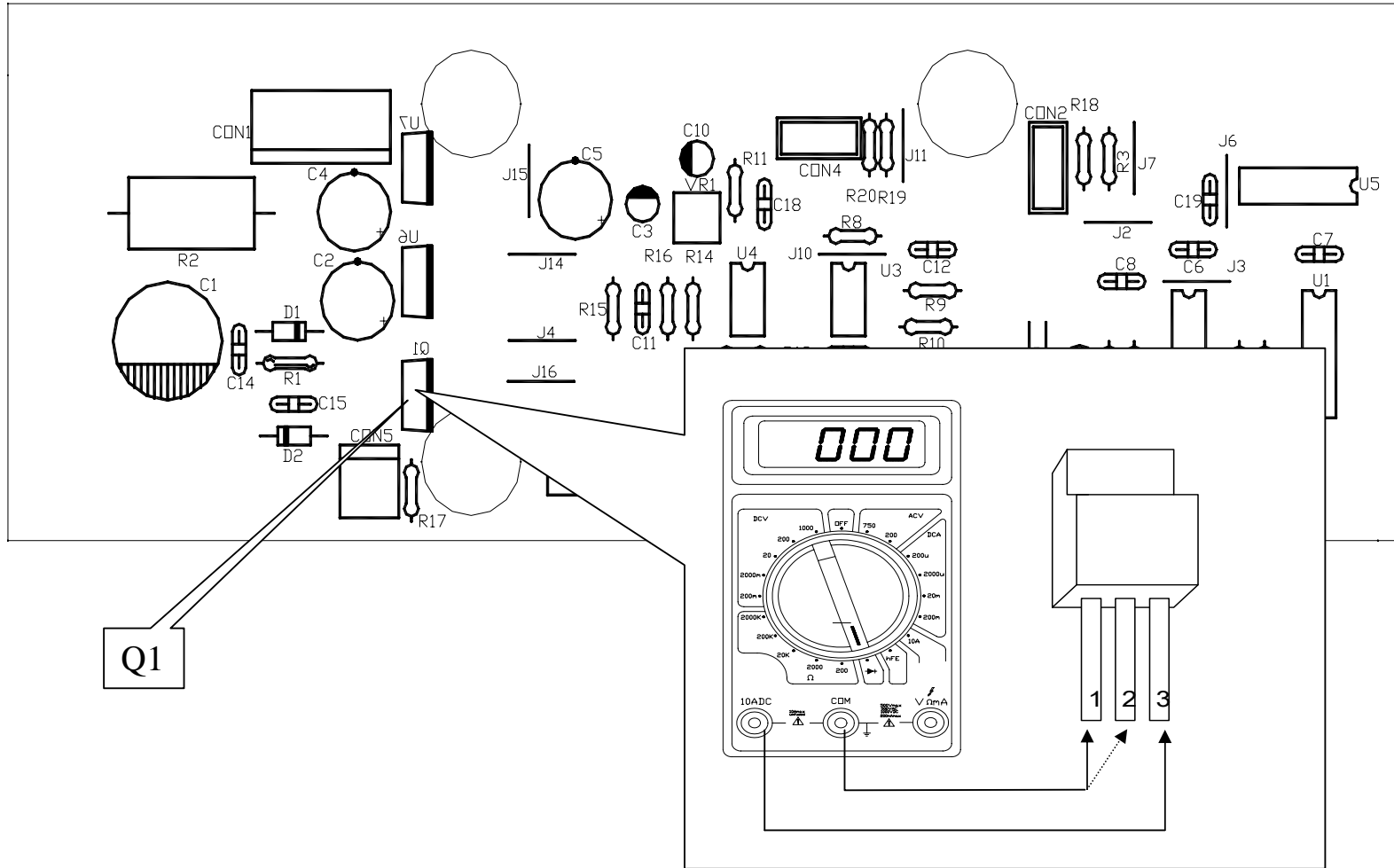

## SPORTS ART INDUSTRIAL CO., LTD.

### **II. Q1 Test Procedure**

- 2-1. Remove the drive board wire connections.
- 2-2. Put the multimeter on the diode setting.
- 2-3. Place the red probe on the first pin of the IGBT. Place the black probe on the third pin.  
Normal reading: not 0.
- 2-4. Place the red probe on the second pin of the IGBT. Place the black probe on the third pin.  
Normal reading: not 0.
- 2-5. If the reading shows 0, the IGBT has a short. Replace the IGBT.

### **III. Symptom of a Malfunction**

- 3-1. Adjust the unit LEVEL value. The resistance does not change.
- 3-2. When Q1 is bad and one pulls the handlebar, resistance will be extremely strong or nonexistent.

## 2100 Rower Drive Board VCC Voltage Test

### I. Drive board VCC voltage test

#### 1. Test Configuration

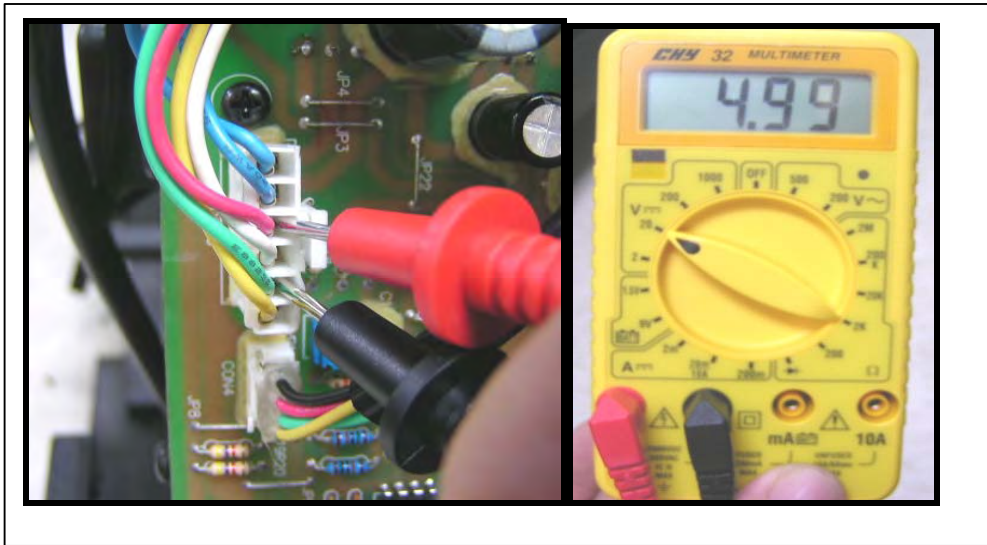

## SPORTS ART INDUSTRIAL CO., LTD.

### **II. Test Procedure**

- 2-1. Put multimeter to the 20 VDC setting. Place probes as shown.
- 2-2. Do not disconnect any wires. Turn on unit power.
- 2-3. Normal reading: 4.8-5.2 VDC.
- 2-4. If not as above, inspect the following:
  - (1) Check the power fuse for continuity.
  - (2) Check whether the transformer has primary and secondary voltages.
  - (3) Drive board.

### **III. Symptom of a Malfunction**

- 3-1. Display does not light. Unit will not operate.

## 2100 Rower Optic Sensor Test

### I. Optic sensor (A) signal test configuration

1. A\_PHASE signal voltage test

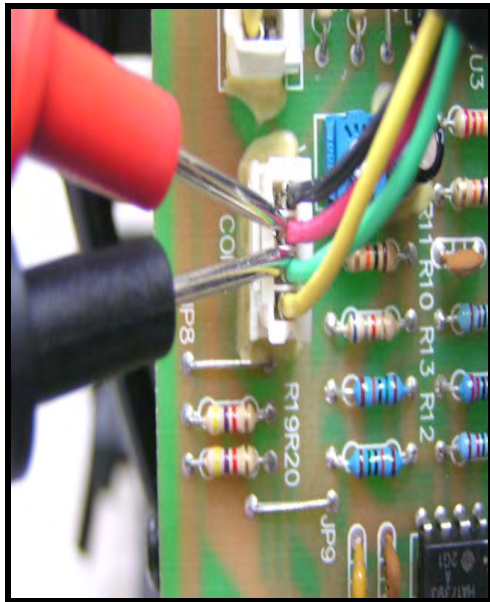

2. B\_PHASE signal voltage test

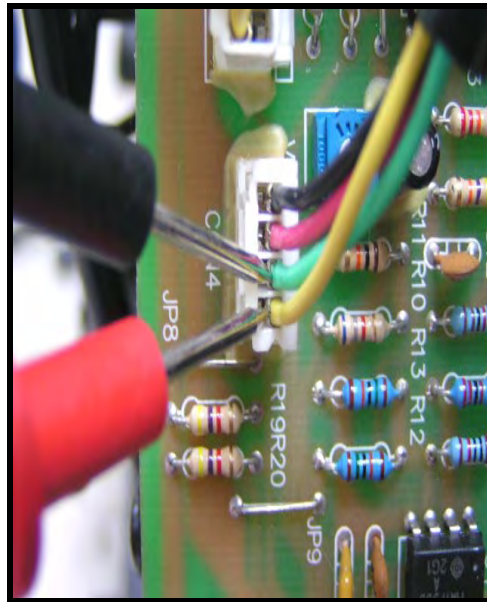

## SPORTS ART INDUSTRIAL CO., LTD.

### **II. Test Procedure**

- 2-1-1. Put multimeter to the 20 VDC setting. Place probes on the red and green wires on the drive board CON4 connector.
- 2-1-2. Do not detach any wires. Have someone exercise on the unit.
- 2-1-3. Normal reading: 1.0~4.5 VDC. The faster the speed, the closer the voltage gets to 2.5 VDC.
- 2-1-4. If the meter shows 5 or 0 VDC, the optic sensor is abnormal. Inspect:
  - (1) the optic sensor signal and the distance between the wheel and the sensor;
  - (2) the optic sensor wire connections.
- 2-2-1. Put the multimeter to the 20 VDC setting. Place probes on the yellow and green wires on the drive board CON4 connector.
- 2-2-2. Do not detach any wires. Have someone exercise on the unit.
- 2-2-3. Normal reading: 1.0~4.5 VDC. The faster the speed, the closer the voltage gets to 2.5 VDC.
- 2-2-4. If the meter shows 5 or 0 VDC, optic sensor is abnormal. Inspect:
  - (1) the optic sensor signal and the distance between the wheel and the sensor;
  - (2) the optic sensor wire connections.

### **III. Symptom of a Malfunction**

- 3-1. Pull the rower handlebar. The display MODE function value does not increase.

## 2100 Rower Optic Sensor Signal Test at the Drive Board

### IV. Optic sensor (B) board signal test configuration

#### 1. C Signal voltage test

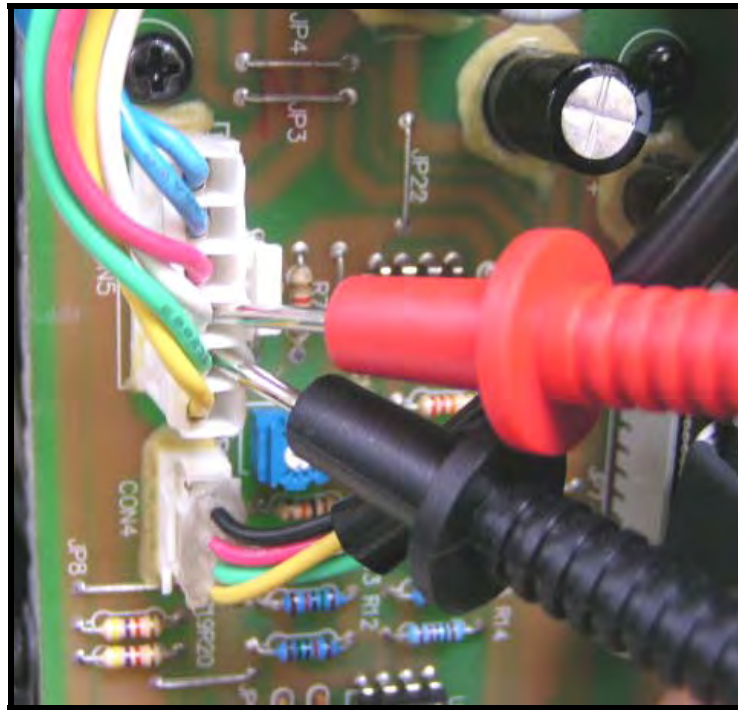

## SPORTS ART INDUSTRIAL CO., LTD.

### **V. Test Procedure**

- 5-1. Put multimeter to the 20 VDC setting. Place probes on the white and green wires of the drive board CON5 connector.
- 5-2. Do not detach any wires. Have someone exercise on the unit.
- 5-3. Normal reading: 1.0~4.5 VDC. The faster the speed, the closer the voltage to 2.5 VDC.
- 5-4. If the voltage is 5 or 0 VDC, the optic sensor is malfunctioning. Inspect:
  - (1) the optic sensor signal and the distance between the sensor and the wheel;
  - (2) the optic sensor wire connections.

### **VI. Symptom of a Malfunction**

- 6-1. Pull the rower handlebar. The display MODE function value does not increase.
- 6-2. Pull the rower handlebar. Resistance varies.

## 2100 Drive Board Resistance Voltage Test

### I. Test Configuration

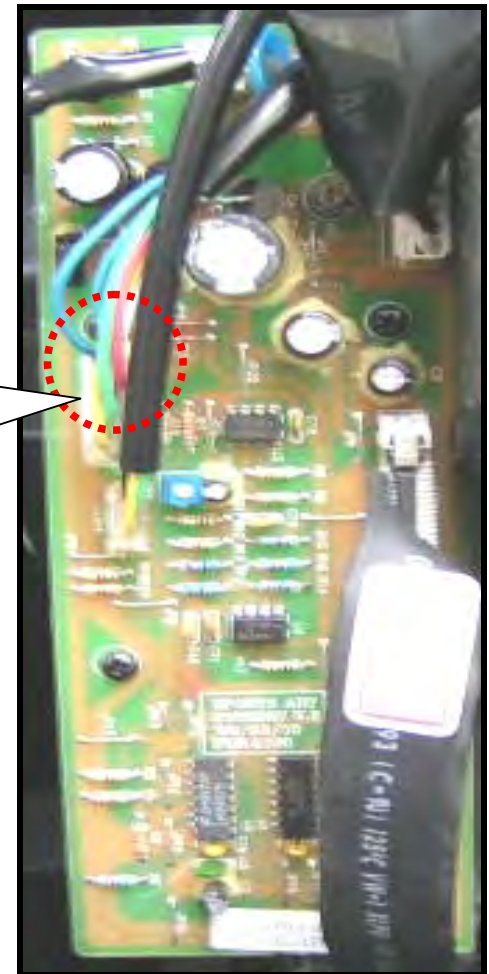
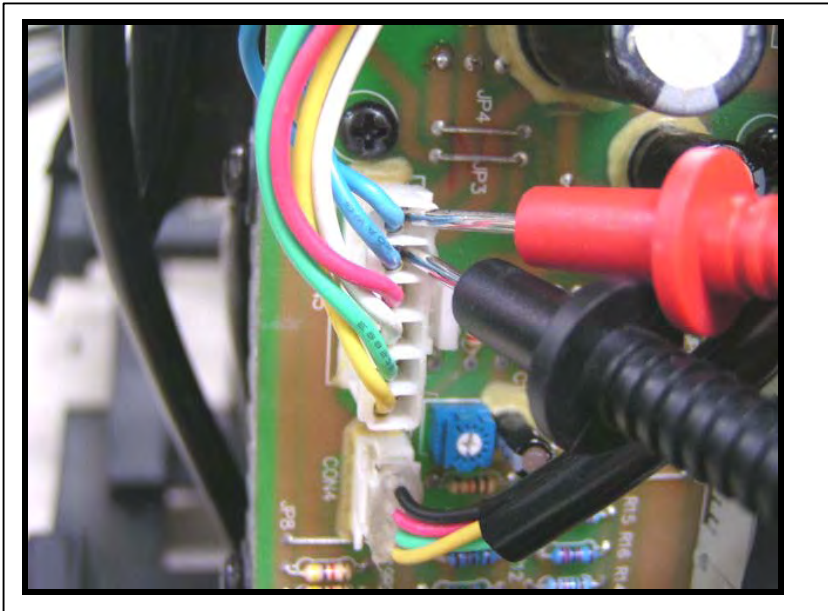

## SPORTS ART INDUSTRIAL CO., LTD.

### **II. Test Procedure**

- 2-1. Put multimeter to the 200 VDC.
- 2-2. Place probes as shown on the two blue wires on the drive board CON5 connector.
- 2-3. Have someone exercise on the unit. Normal reading: 0.5-20 VDC. Unit does have resistance.
- 2-4. If the voltage exceeds 20 VDC and there is no change in resistance, there is full resistance.
- 2-5. If the voltage is 0 VDC and there is no change in resistance, there is no resistance.

### **III. Symptom of a Malfunction**

- 3-1. Pull the rower handlebar, at any LEVEL setting, there is full resistance.
- 3-2. Pull the rower handlebar, at any LEVEL setting, there is no resistance.

## 2100 Rower Display Board VCC Voltage Test

### I. VCC voltage test configuration

Capacitor C24 ends

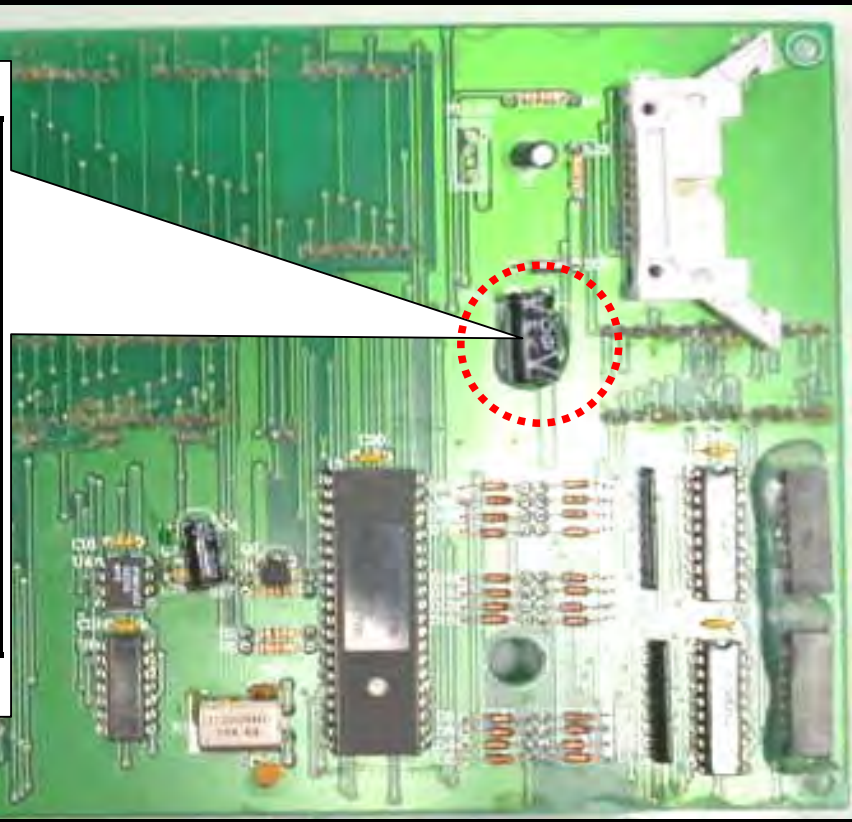
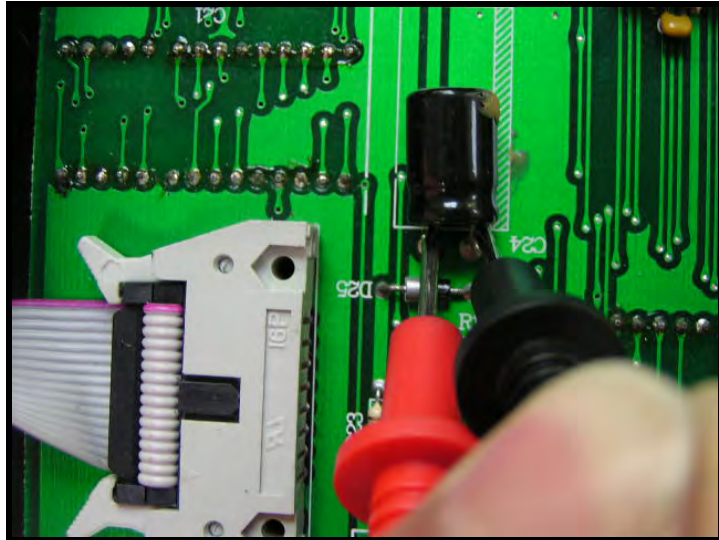

## SPORTS ART INDUSTRIAL CO., LTD.

### **II. Test Procedure**

- 2-1. Put multimeter to the 20 VDC setting.
- 2-2. Place probes on the two pins of capacitor C24 as shown.
- 2-3. Turn on unit power. Normal reading: 4.8-5.2 VDC. The display “beeps” once and lights up.
- 2-4. If the voltage is 5 VDC, but the display does not light, reinstall program (U10) IC and ICMM5451(U11).
- 2-5. If there is no voltage, inspect the drive board for 5 VDC.

### **III. Symptom of a Malfunction**

- 3-1. Turn on unit power. The display does not light up.

## 2100 Rower Transformer Test Configuration

### I. Test Configuration



CON1 Transformer Connector



Drive Board

## SPORTS ART INDUSTRIAL CO., LTD.

### II. Test Procedure

- 2-1. The transformer is connected to the drive board through CON1.
- 2-2. Set the multimeter to the 500 VAC setting.
- 2-3. Turn on unit power. Place probes separately on the primary wires, which are both red (North America) or both blue (Europe) as shown.
- 2-4. Normal reading: 110 VAC (or 220 VAC).
- 2-5. Test secondary wires as shown below. Normal readings follow.

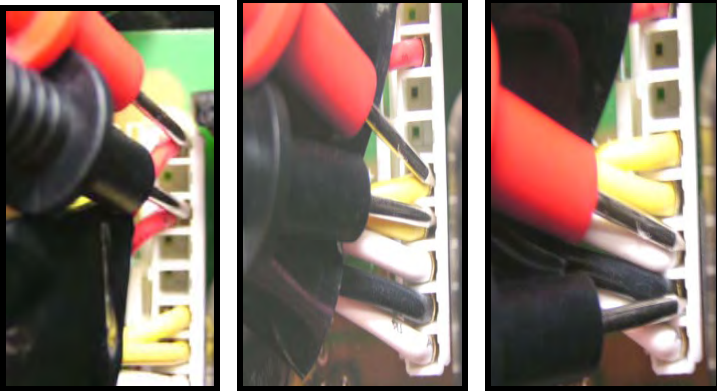

Transformer Wires		Voltage
Red Probe	Black Probe	
Red/(Blue)	Red/(Blue)	110V(Red)/220V(Blue)
Yellow	Yellow	8.5-9.5V
White	Black	17.9-19.1V
White	Black	17.9-19.1V

### III. Symptom of a Malfunction

- 3-1. If there is no voltage across the transformer primary wires:
  - (1) Inspect the drive board CON2 wire connections.
- 3-2. If there is voltage across the primary wires but none across secondary wires, the transformer is bad. Replace it.

## 2100 Rower Magnet Test

### I. Test Configuration

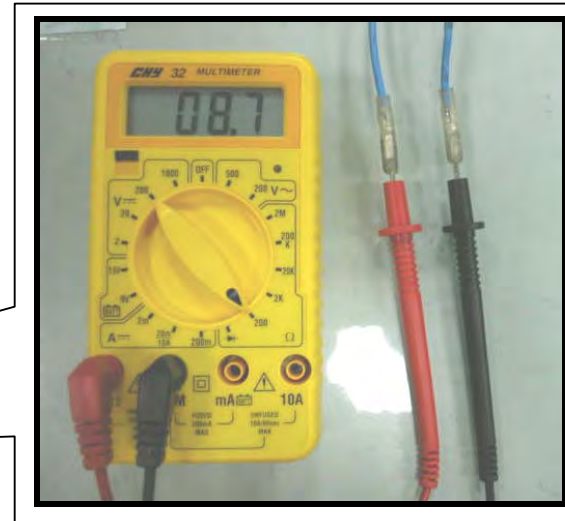
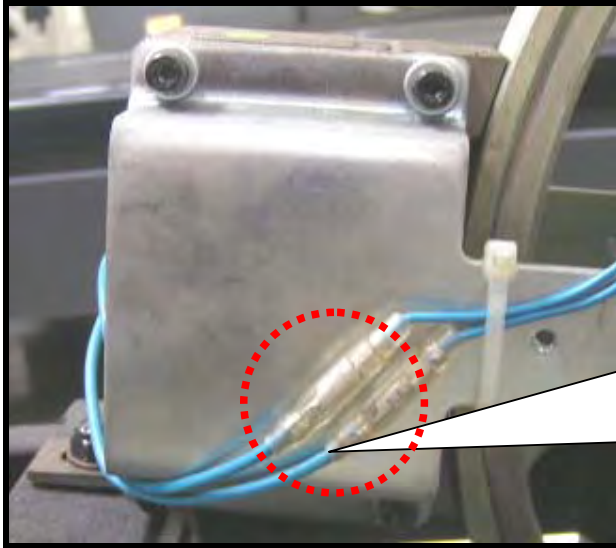

### I. Test Procedure

- 2-1. Detach the magnet wires.
- 2-2. Set multimeter to the OHM setting. Place a probe on each wire of the magnet.
- 2-3. Normal reading: 10 OHM.
- 2-4. If there is no reading whatsoever, the magnet is bad.

## 2100 Rower Remote Transmitter Test

### I. Test Configuration

Remote Transmitter



## SPORTS ART INDUSTRIAL CO., LTD.

### **II. Test Procedure**

- 2-1. Put multimeter on the 20 VDC setting.
- 2-2. Place probes as shown on the battery ends.
- 2-3. Normal reading: 3 VDC. After testing, install batteries into the unit.
- 2-4. Turn on unit power. After the display lights, press the switch on the remote controller to position I or II. The display LEVEL window values can be set in both directions.

### **III. Inspection**

- 3-1. If the voltage reading shows less than 3 VDC, please replace the batteries.
- 3-2. Press the remote switch. If the display LEVEL window value does not change, inspect the wire connection from the remote control to the display. If there is no action, replace the receiver and transmitter as a test.

2100 Rower

VIII. Blowup Diagrams and Part Numbers

**SPORTS ART INDUSTRIAL CO., LTD.**

# SPORTS ART INDUSTRIAL CO., LTD.

## I. 2100 Rower Blow Up Diagram

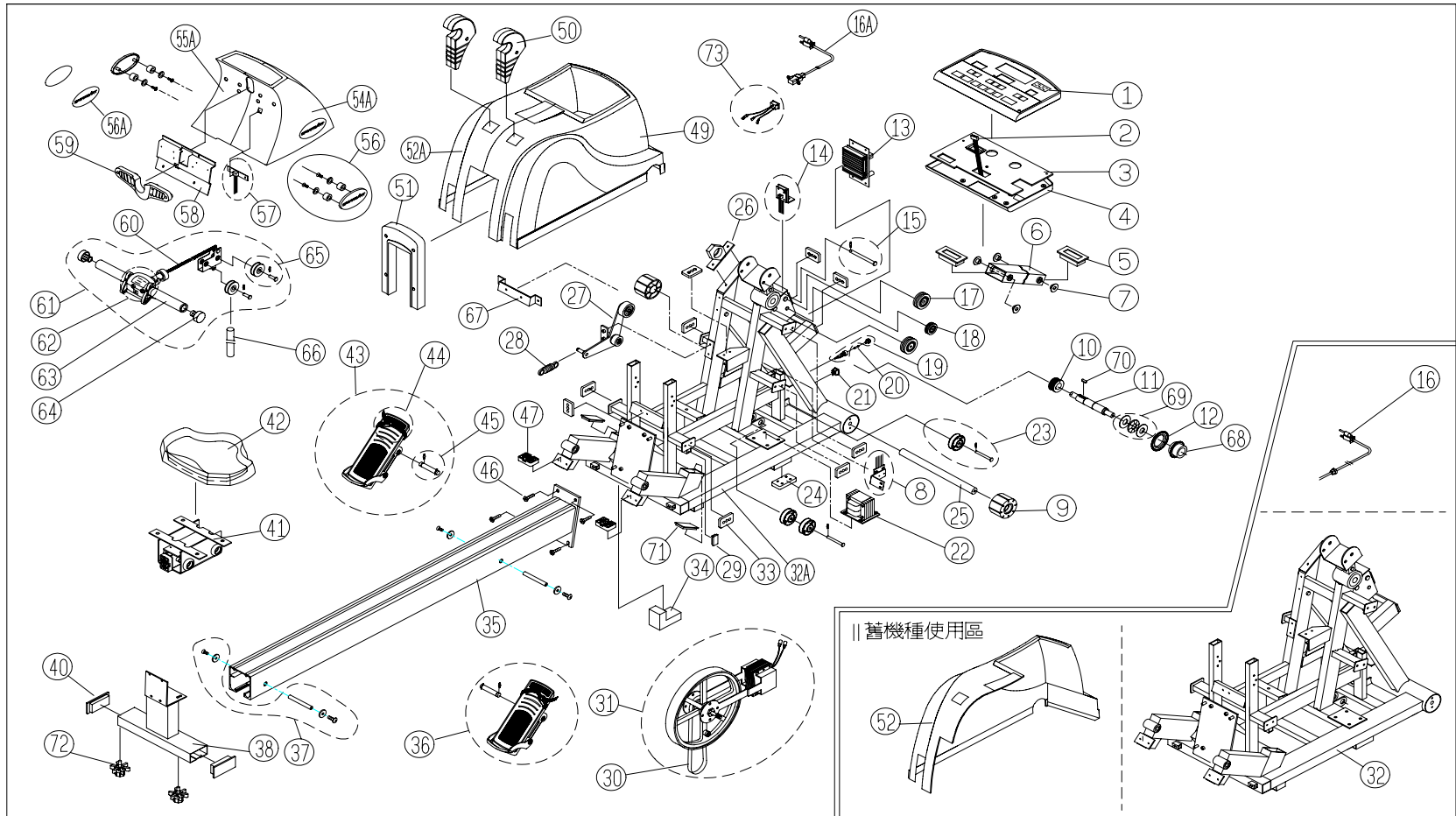

Note: Numbers are subject to change. For most up-to-date information, see [www.sportsartamerica.com](http://www.sportsartamerica.com).

SPORTS ART INDUSTRIAL CO., LTD.

**II. 2100 Rower Part B.O.M. Table (1)**

No.	Name	Factory Part #	QTY	No.	Name	Factory Part #	QTY
1	Display---No heart rate	120191001	1	16	Power cord ----Japanese 2-prong	080074053	1
2	Data cable © display board to drive board	020127030	1	16	Power cord ----UL	080074063	1
3	Steel plate	12015004W	1	16	Power cord ----Israel	080074073	1
4	Display – back panel	120130123	1	16A	Power cord ----European	020174010	1
5	Sleeve	120130143	2	16A	Power cord ----Australian	020174020	1
6	Display post - black	12015008W	2	16A	Power cord ----British (5A)	020174030	1
7	Allen bolt	020113270	4	16A	Power cord ----Swiss	020174040	1
8	Optical sensor – flywheel	020151100	1	16A	Power cord ----UL	020174050	1
9	Transport wheel	050430023	2	16A	Power cord ----Israeli	020174060	1
10	Drive pulley	020113470	1	16A	Power cord ----Japanese 2-pin	020174070	1
11	Axle – drive assembly	020113420	1	16A	Power cord ----Chinese	020174080	1
12	Optical wheel – drive assembly (30 teeth)	020130130	1	17	Nylon pulley – top, large	020153020	1
13	Drive board	020120061	1	18	Nylon pulley – top, small	020153030	1
14	Optical sensor – drive assembly	020151090	1	19	Fuse holder	000028500	1
15	Limit pin	120191010	1	20	Fuse----fast acting	000028020	1
16	Power cord ----European	080074013	1	21	On/Off switch	000125020	1
16	Power cord ---- Australian	080074023	1	22	Transformer----110V	020123010	1
16	Power cord ----British (5A)	080074033	1	22	Transformer----220V	020123020	1
16	Power cord ----Swiss	080074043	1	22	Transformer----100V	020123030	1

Numbers shown here are not used by SportsArt America. Please refer to [www.sportsartamerica.com](http://www.sportsartamerica.com).

SPORTS ART INDUSTRIAL CO., LTD.

**II. 2100 Rower Part B.O.M. Table (2)**

No.	Name	Factory Part #	QTY	No.	Name	Factory Part #	QTY
23	Nylon pulley – bottom	120191011	1	42	Seat	050434013	1
24	Front support block	020131063	1	43	Foot rest assembly – left	120191007	1
25	Axle – transport wheel	08001306F	1	44	Foot strap	120193010	2
26	Bearing – drive assembly	12015013W	1	45	Shaft – foot rest	120191013	2
27	Idler pulley	020151190	1	46	Bolt – seat rail	020113090	4
28	Idler spring	050104030	1	47	Bump pad – pedal	020131013	2
29	End cap – incline	010830013	1	48	Sidecover label – right	020163095	1
30	Drive belt	020105030	1	49	Sidecover – right	120130173	1
31	Flywheel/magnet assembly	120191009	1	49	★Sidecover – right ----X2073	12013019R	1
32	Frame----old type	12015001W	1	49	Sidecover – left----X2073	020130163	1
32A	Frame	12015007W	1	50	Handlebar holder	020131023	2
33	Isolator block	080053043	9	51	Cover – rear	020130333	1
34	Wood block (for assembly only)	0201420010	1	52	Sidecover - left	120130163	1
35	Seat rail	120150033	1	53	Sidecover label - left	020163094	1
36	Foot rest assembly – right	120191008	1	54A	Top cover – right	120191018	1
37	Seat stop assembly	120191012	1	55A	Top cover – left	120191017	1
38	Rear support frame	12015002W	1	56	SportsArt Badge	160291001	2
40	End cap – 1-1/2”x3”	030330070	2	56A	SportsArt Badge	020163040	2
41	Seat carriage assembly	120191003	1	57	IR receiver	120191005	1

Numbers shown here are not used by SportsArt America. Please refer to [www.sportsartamerica.com](http://www.sportsartamerica.com).

SPORTS ART INDUSTRIAL CO., LTD.

**II. 2100 Rower Part B.O.M. Table (3)**

No.	Name	Part	QTY	No.	Name	Part	QTY
58	Steel plate - upper	12011003W	1		Display board	120191500	1
59	Impact cushion	020131073	1				
60	Pull chain	120104010	1				
61	Handlebar/pulley/chain assembly	120191014	1				
62	IR transmitter	120191006	1				
63	Foam	120191021	1				
64	End cap – grip	010930011	2				
65	Nylon pulley – top, medium	120191015	2				
66	Elastic strap	12013105G	1				
67	Steel plate – lower	12011028W	1				
68	One-way bearing/sprocket	020113140	1				
69	Thrust bearing and race	000004270	1				
70	Woodruff key	020113490	1				
71	End cap – 1-1/2” x 3”	020130293	1				
72	Leveler	120191004	2				
73	Power cord splitter	015027140	1				
	Hardware kit	120151010	1				
	Program IC-----27C512	030390010	1				
	★Keys-----10-KEY	020125040	1				

Numbers shown here are not used by SportsArt America. Please refer to [www.sportsartamerica.com](http://www.sportsartamerica.com).