

SPORTSART *7003 Series*

**COMMERCIAL GRADE STAIR CLIMBER
TROUBLE SHOOTING MANUAL**

COMMERCIAL GRADE STAIR CLIMBER TROUBLE SHOOTING MANUAL

It is recommended that only certified technicians with expert knowledge of this stair climber attempt to service this equipment, to prevent harm to yourself or damage to the equipment.

To service this equipment, you may need the following:

- . One extra electronics package
- . One extra 16 pin cable
- . One extra drive board

A. BLANK DISPLAY

If you turn on the adapter switch and no words appear on the display, please see below:

1. IF THE ADAPTER SWITCH IS IN THE " - " POSITION AND THERE IS NO LIGHT:

- a. Check if the power cord is plugged securely into the wall socket.(see Fig. 1).

Make sure the adapter plug to the Stair Climber is securely connected, please refer to the ADAPTER REMOVAL AND INSTALLATION PROCEDURE (page 109)for more information

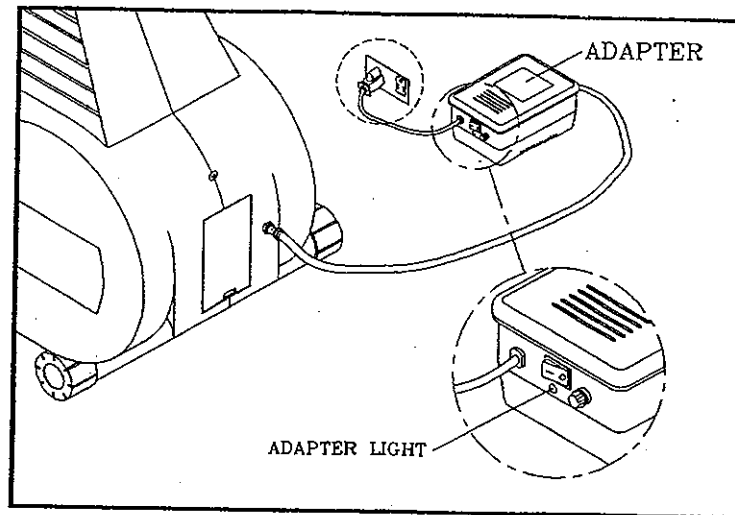

Fig. 1

- b. If the adapter switch is still not lit after the above steps have been followed, then the adapter switch fuse needs to be replaced. Remove and replace the 1 Amp fuse at the front of the adapter, please refer to the ADAPTER FUSE REMOVAL AND INSTALLATION PROCEDURE (page 118) for more information.
- c. If the adapter switch is still not lit after replacing the fuse, then the adapter is damaged and must be replaced, please refer to the ADAPTER REMOVAL AND INSTALLATION PROCEDURE (page 116) for more information.
- d. If the unit still refuses to respond after all the listed steps have been

performed as instructed, then the drive board is damaged and must be replaced, please refer to the DRIVE BOARD REMOVAL AND INSTALLATION PROCEDURE (page 31) for more information.

2. IF THE ADAPTER SWITCH IS LIT:

- a. Make sure the adapter connector is firmly in its socket on the front of the stair climber.
- b. If the display is still blank, make sure the retaining clip connected into its socket securely. (see Fig.1).

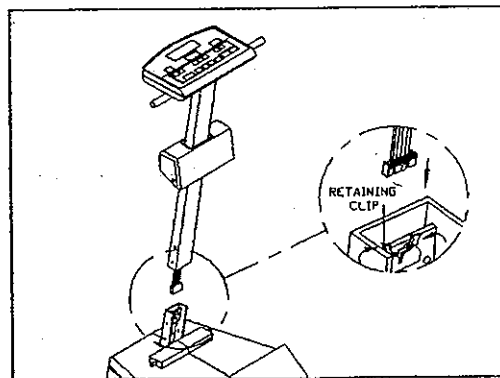

Fig. 1

- c. Make sure all connectors to the drive board are plugged in correctly and securely in place (see Fig. 2).
- d. Make sure the color wires connected are correctly. (see Fig. 3).

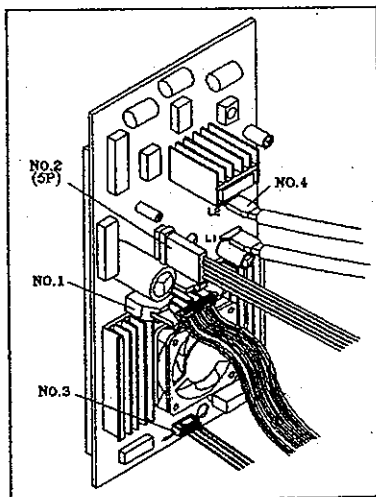

Fig. 2

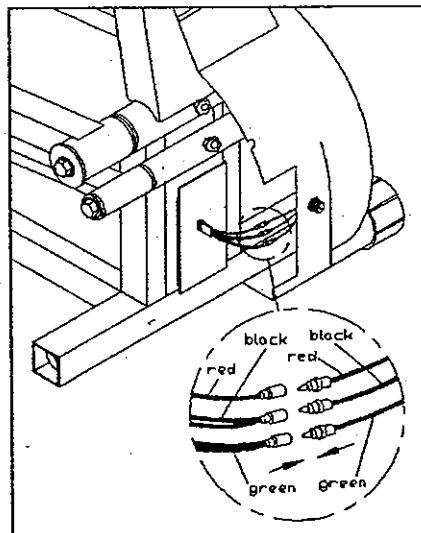

Fig. 3

- e. If the unit still fails to respond, please refer to the QUICK EXAMINATION PROCEDURE (page 8) for more information.
- f. If, after the QUICK EXAMINATION PROCEDURE has been performed, the display still refuses to respond, then the adapter is damaged and must be replaced, please refer to the ADAPTER REMOVAL AND INSTALLATION PROCEDURE (page 116) for more information.

B. IF THE TENSION (LOAD) DOES NOT RESPOND

1. If there is no tension (load), and the display has no "Step/Minute" reading or responds improperly while you are climbing, please see below:

a. Make sure the retaining clip connected into its socket securely.(see Fig.1)

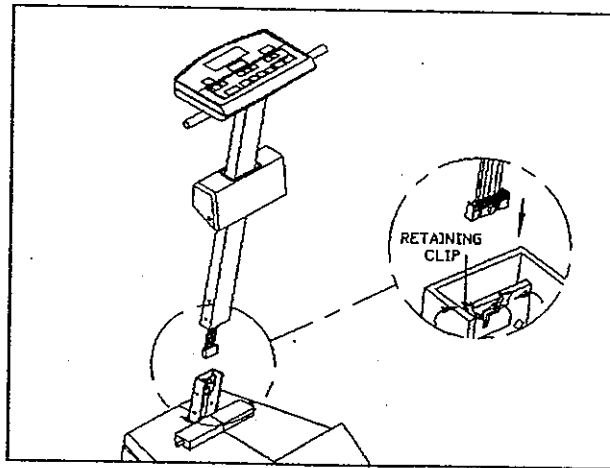

Fig. 1

b. Make sure all connectors to the drive board are plugged in correctly and securely in place (see Fig. 2).

c. Make sure all color wires connected are correctly.(see Fig. 3).

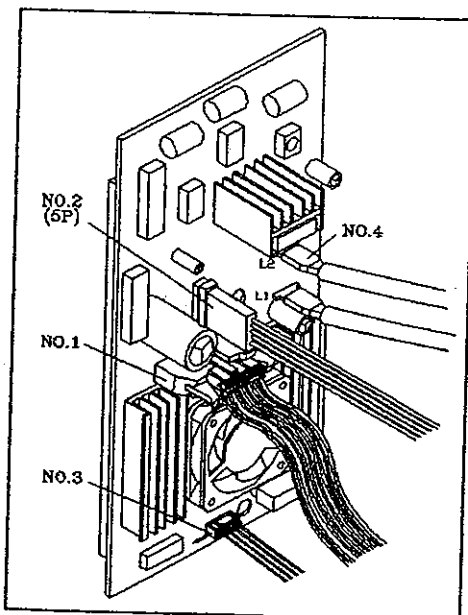

Fig. 2

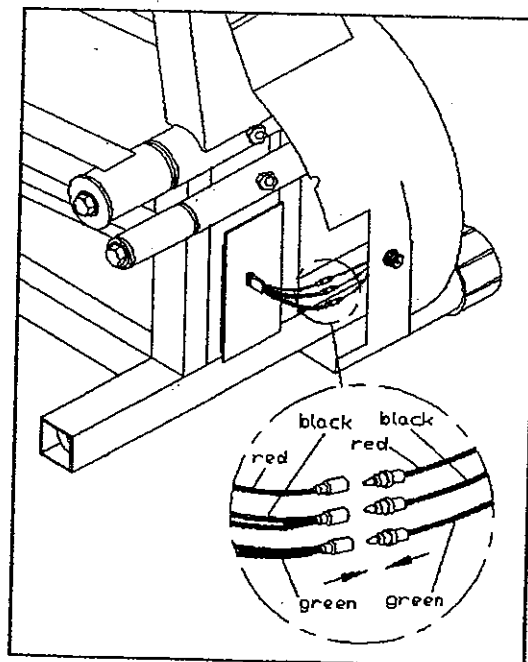

Fig. 3

- d. If the unit still fails to respond, please refer to the QUICK EXAMINATION PROCEDURE (page 8) for more information.
 - e. If the stair climber still refuses to respond after the Quick Examination Procedure, that means the optical switch is damaged, and needs to be replaced, please refer to the OPTICAL SWITCH REMOVAL AND INSTALLATION PROCEDURE (page 61) for more information.
2. If the display has a "Step/Minute" reading:
- a. If the display is still blank, make sure the retaining clip connected into its socket securely (see Fig1)

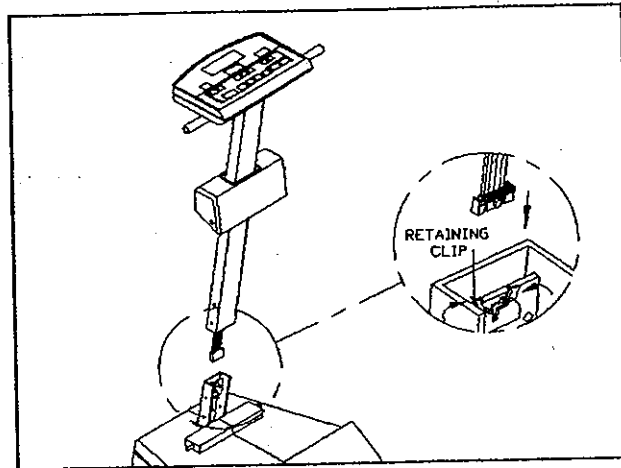

Fig. 1

- b. Make sure all the connectors to the drive board are plugged in correctly and securely in place (see Fig. 2).

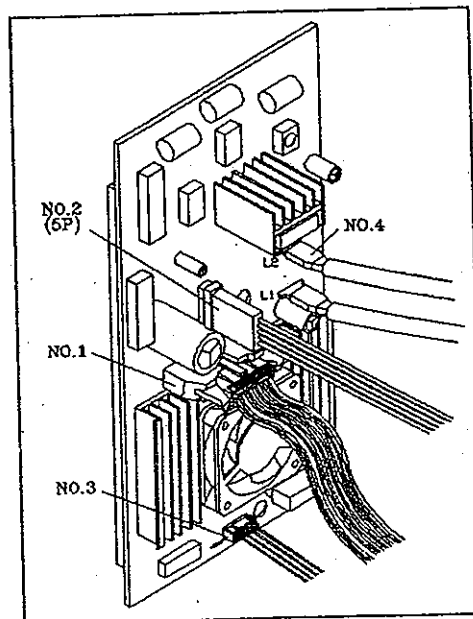

Fig. 2

c. Make sure the color wires connected are correctly. (see Fig.3).

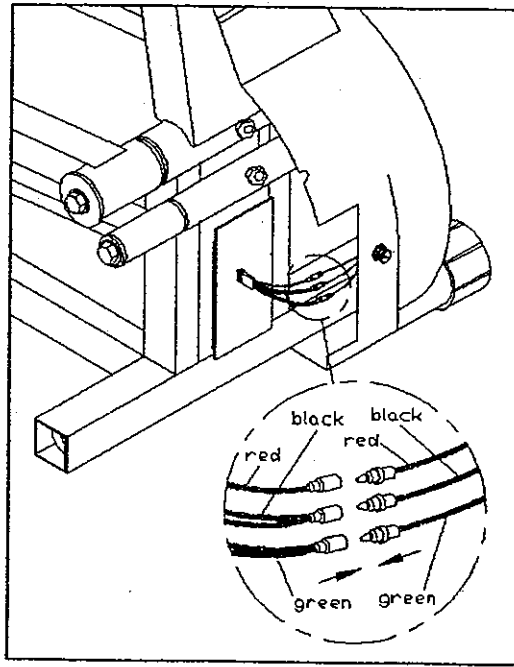

Fig. 3

- d. If the unit still fails to respond, please refer to the QUICK EXAMINATION PROCEDURE (page 8) for more information.
- e. If the stair climber still refuses to respond after the Quick Examination Procedure, the eddy current system is damaged and must be replaced, please refer to EDDY CURRENT SYSTEM REMOVAL AND INSTALLATION PROCEDURE (page 44) for more information.

C. WHEN STEPPING, TENSION IS INCONSISTENT

When this problem occurs, you should replace the POLY-V BELT, CHAIN WHEEL AND GEAR SHAFT. Please refer to the STAIR ARM BELT REMOVAL AND INSTALLATION PROCEDURE (page 98), CHAIN/BELT WHEEL AND GEAR SHAFT REMOVAL AND INSTALLATION PROCEDURE (page 82) for more information.

D. QUICK EXAMINATION PROCEDURE

To examine damaged parts, you may need the following:

- . One extra electronics package
- . One extra 16 pin cable
- . One terminal
- . One extra drive board

1. If, after trying all the listed steps as instructed, the unit still responds improperly, take a new electronics package and connect it to a new 16 pin cable, then plug the 16 pin cable into the correct socket on the original drive board (see Fig. 1).

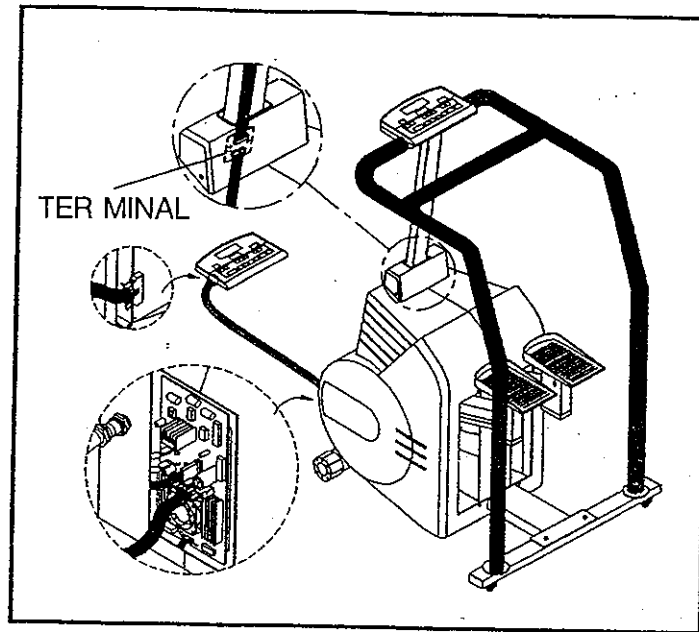

Fig. 1

2. If the problem remains, then the drive board is damaged, and must be replaced. Please refer to **DRIVE BOARD REMOVAL AND INSTALLATION PROCEDURE** (page 31) for more information.
3. If the unit functions properly, the 16 pin cable from the electronics package to the terminal, the 16 pin cable from the terminal to the drive board, the terminal itself, or the electronics package is damaged.

First replace the 16 pin cable from the electronics package to the terminal, please refer to the **ELECTRONICS PACKAGE 16 PIN CABLE REMOVAL AND INSTALLATION PROCEDURE** (page 25) for more information. If the unit responds properly, this was the problem.

If the unit still fails to respond, replace the 16 pin cable from the terminal to the drive board, please refer to the **DRIVE BOARD 16 PIN CABLE REMOVAL AND INSTALLATION PROCEDURE** (page 38) for more information. If the unit responds properly, this was the problem.

If the unit still fails to respond, replace the terminal, please refer to the

TERMINAL REMOVAL AND INSTALLATION PROCEDURE (page 69) for more information. If the unit responds properly, this was the problem.

If the unit still fails to respond, then the electronics package is damaged and must be replaced. Please refer to ELECTRONICS PACKAGE REMOVAL AND INSTALLATION PROCEDURE (page 23) for more information.

For your information:

a. If the following occurs, the electronics package may be damaged:

- . No beep sounds
- . Display is garbled
- . Key pad does not respond.

Please refer to ELECTRONIC PACKAGE REMOVAL AND INSTALLATION PROCEDURE (page 23) for more information.

b. If the following occurs, the drive board may be damaged:

- . Tension (load) loss
- . The adapter fuse continues to blow after the adapter has been replaced

Please refer to DRIVE BOARD REMOVAL AND INSTALLATION PROCEDURE (page 31) for more information.

E. STAIR ARM FAILURE

1. If the stair arms lock and cannot go down, see below:
 - a. Make sure you enter your correct body weight.
 - b. If the unit still fails to respond, please refer to the QUICK EXAMINATION PROCEDURE (page 8) for more information.
 - c. If the unit still responds improperly, then the eddy current system is damaged and must be replaced. Please refer to EDDY CURRENT SYSTEM REMOVAL AND INSTALLATION PROCEDURE (page 44) for more information.
2. If the stair arms do not return to their starting position:
 - a. Make sure the springs are connected properly and not broken. If they are broken, they need to be replaced. Please refer to the SPRING REMOVAL AND INSTALLATION PROCEDURE (page 108) for more information.
 - b. Check the poly-V belts for damage. If they are damaged, they must be replaced. Please refer to the STAIR ARM BELT REMOVAL AND INSTALLATION PROCEDURE (page 98) for more information.

F. STAIR ARM REMOVAL AND INSTALLATION

1. Remove the two screws securing the post shroud (see Fig. 1 & 2).

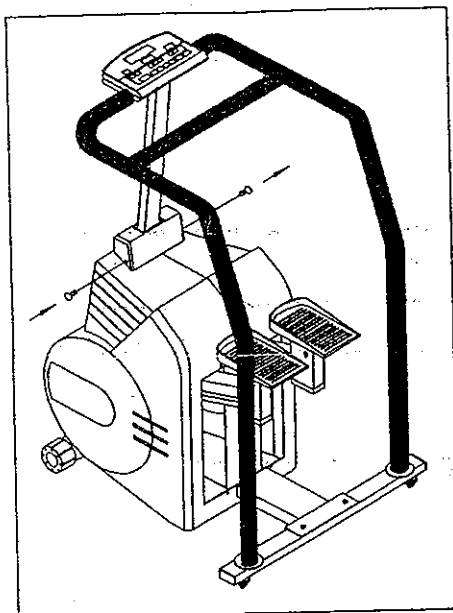

Fig.1

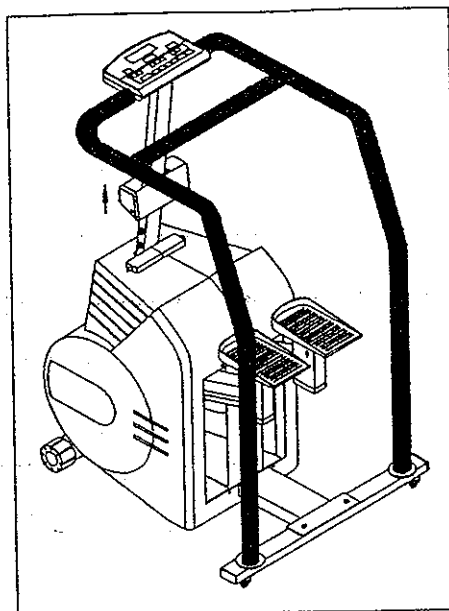

Fig. 2

2. Remove the transport wheel labels first, then unscrew the transport wheels on the front of the stair climber. Remove both wheels (see Fig. 3).

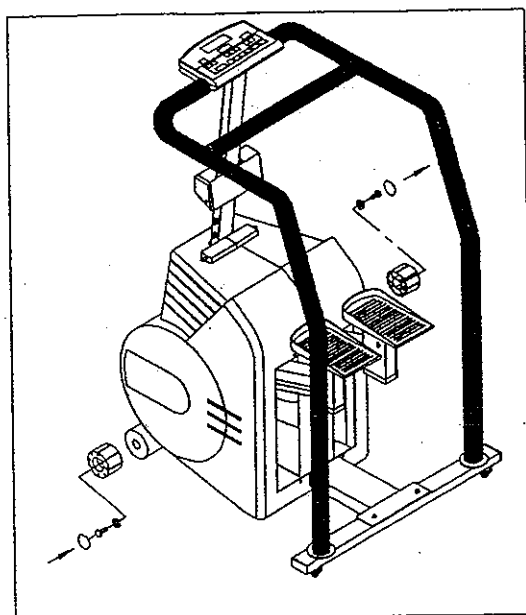

Fig. 3

3. Remove the four screws securing the front cover (see Fig. 4).

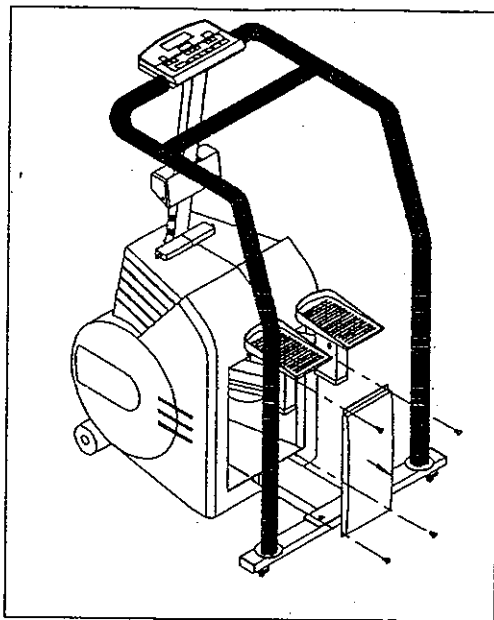

Fig. 4

4. Remove the repair window (see Fig. 5).

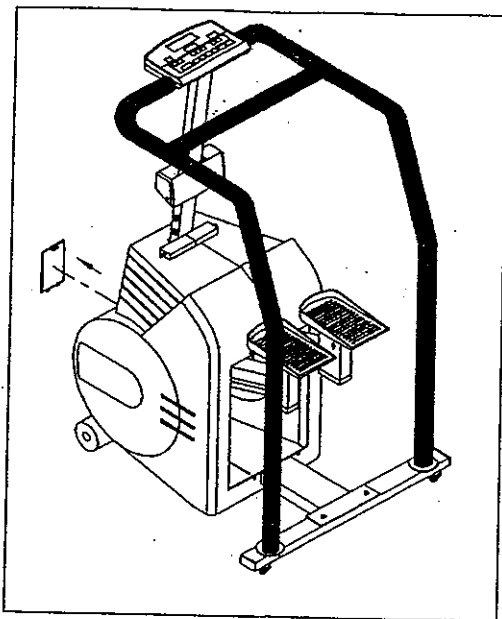

Fig 5. (7003)

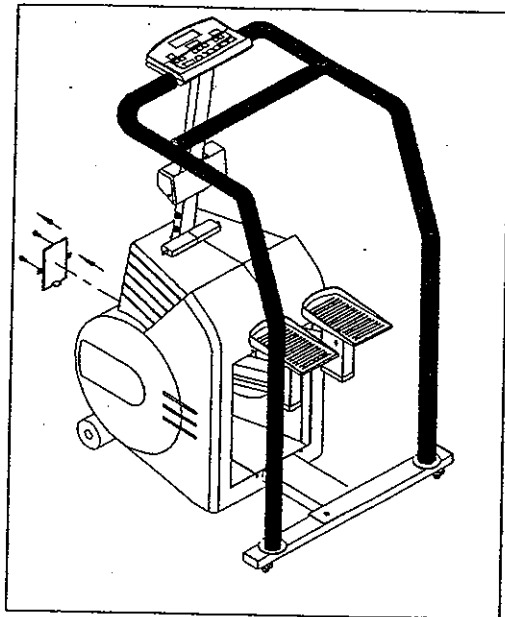

Fig 5. (7003/7003B/7003C/7003N)

5. Remove the nine screws securing the main shroud (see Fig. 6).

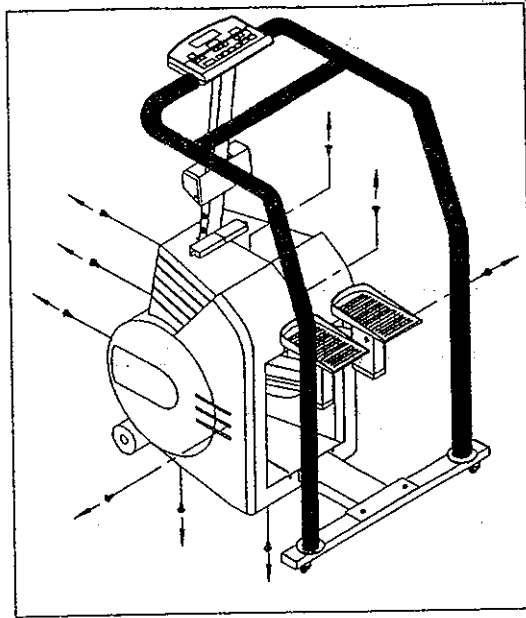

Fig. 6

6. Remove the main shroud (see Fig. 7).

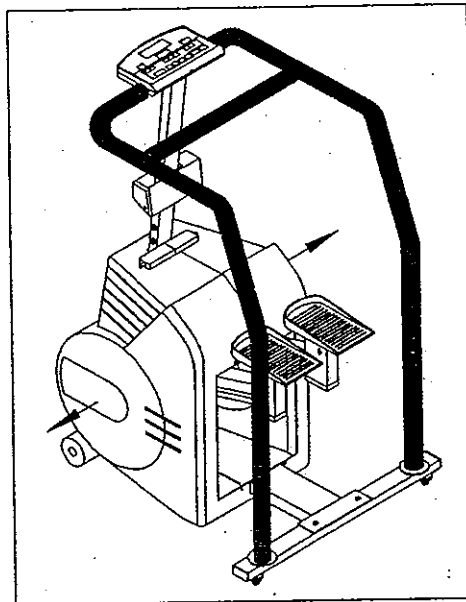

Fig. 7

7. Remove the two springs by following the steps in Fig. 8 to Fig. 8-2.

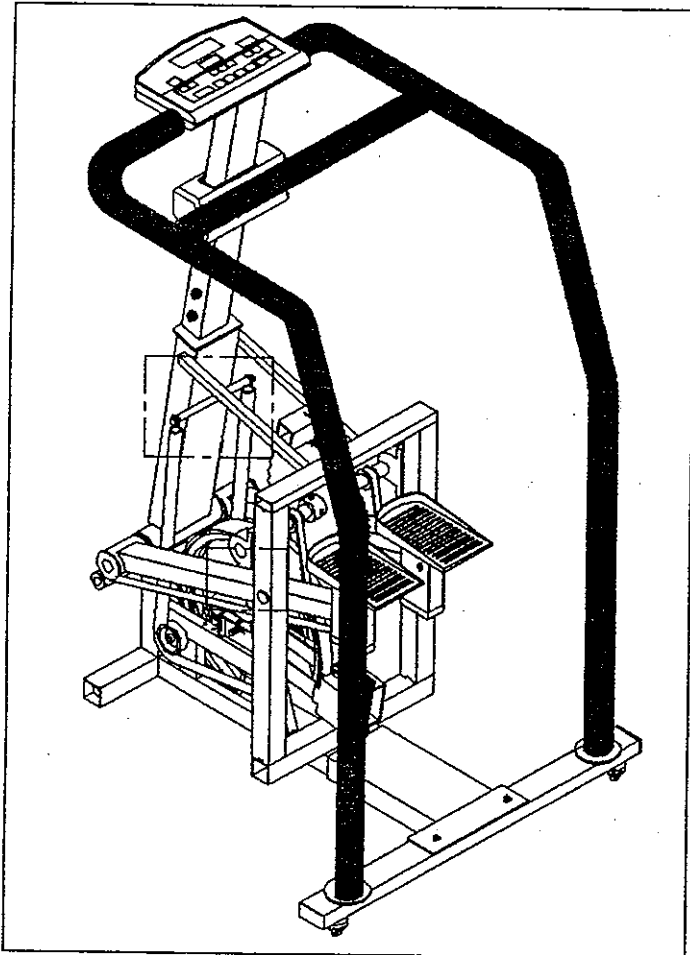

Fig. 8

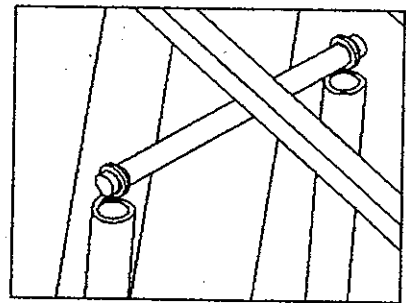

Fig. 8-1

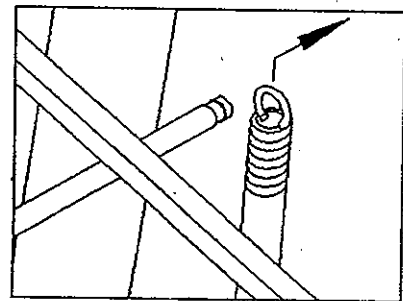

Fig. 8-2

8. Unscrew the screw and washer on the end of the stair arm belt on each side (see Fig. 9).

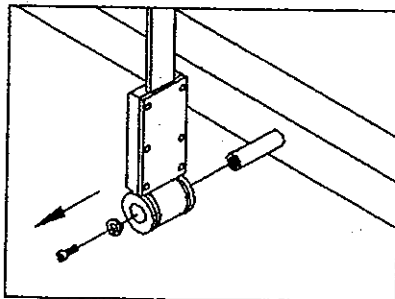

Fig. 9

9. Remove the two screws securing both stair arms (see Fig 10).

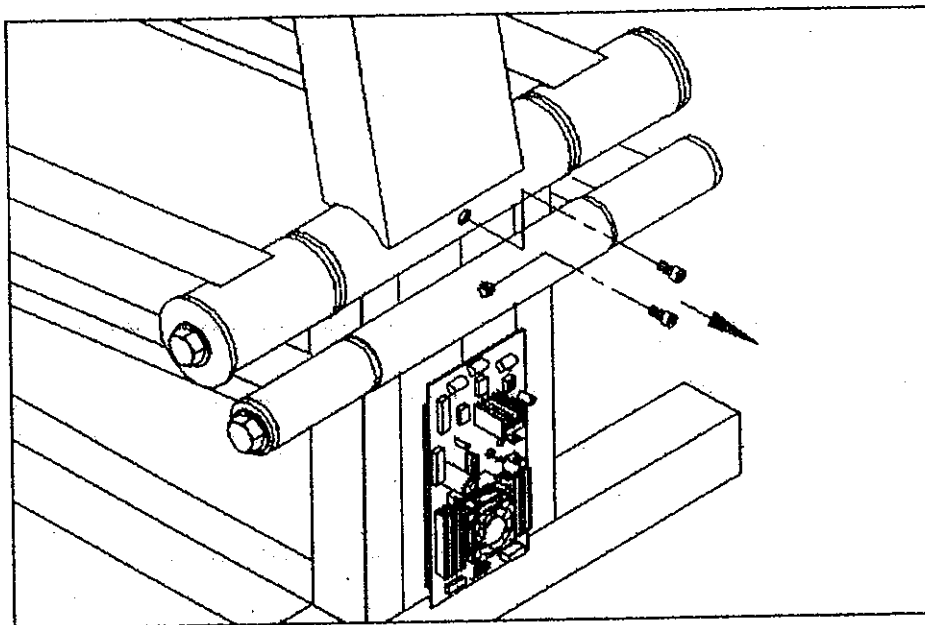

Fig. 10

10. Unscrew the 4 screws and 8 washers securing the two shafts inside the stair arms, then remove both shafts (see Fig. 11).

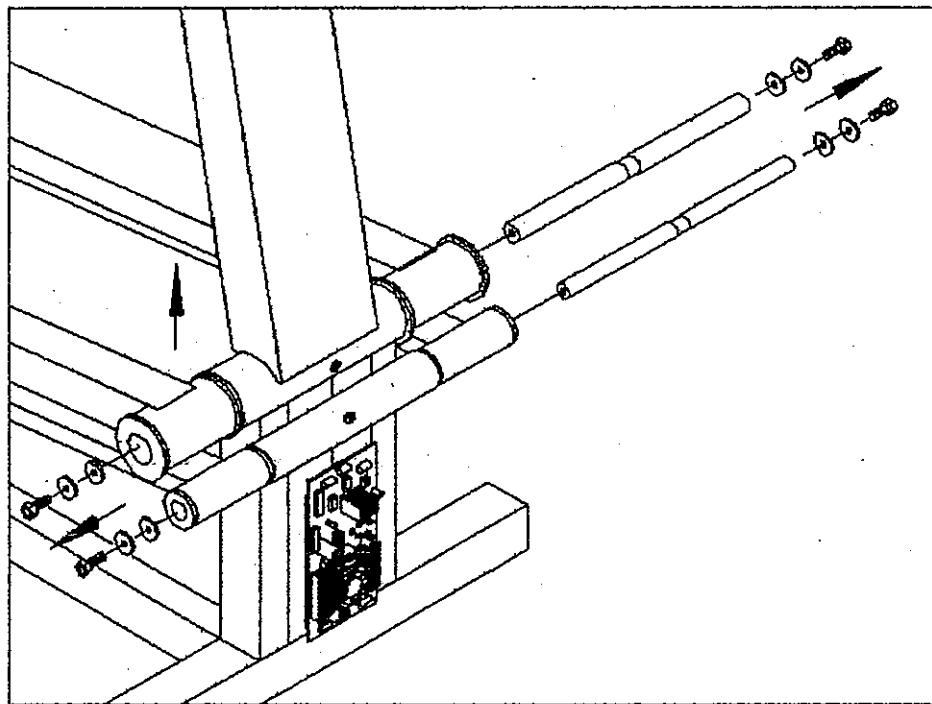

Fig. 11

11. There are two stair arm pieces (upper and lower) connected to each foot pad.

Use a clip to remove the two C-rings and two pins securing the foot pad.

Remove both foot pads and separate the foot pads from their stair arms (see Fig. 12 & 13).

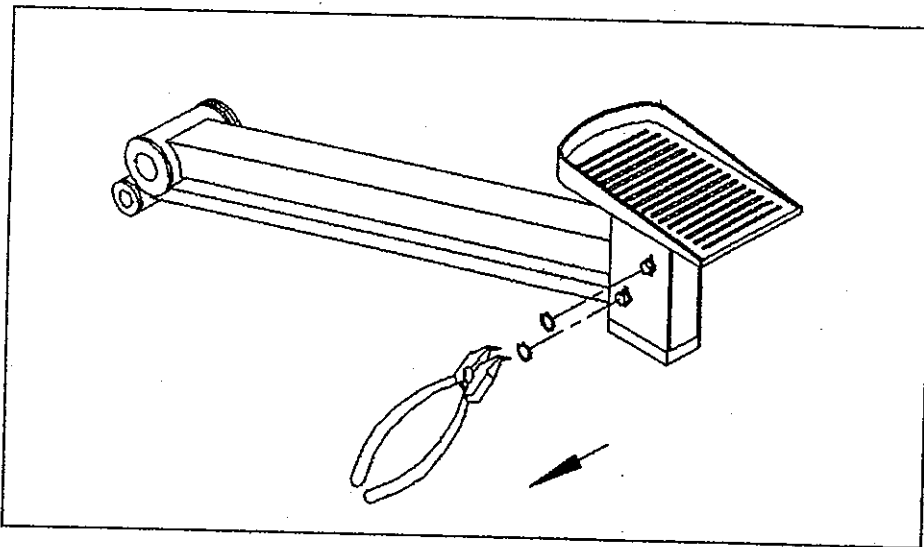

Fig. 12

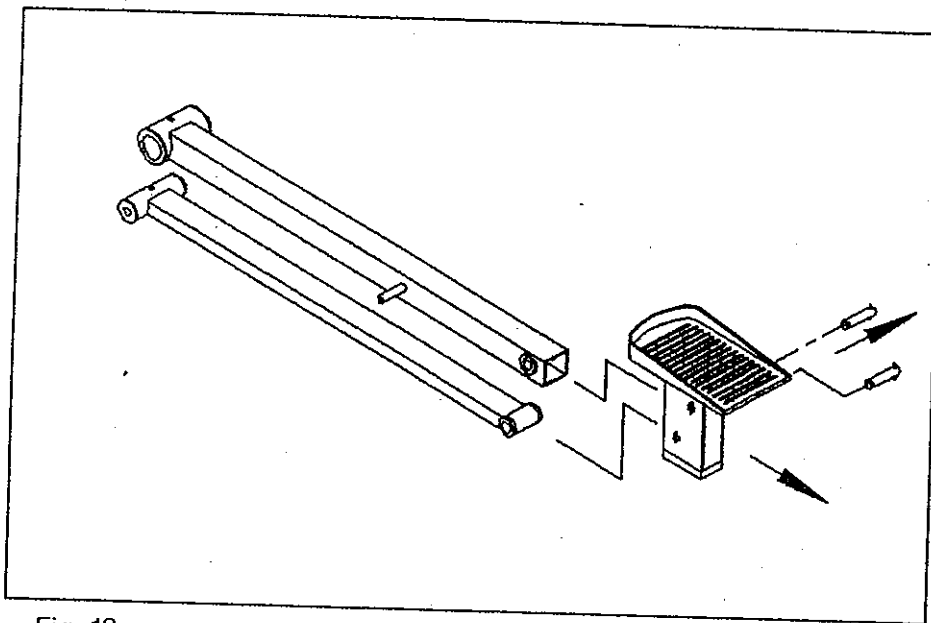

Fig. 13

To install:

1. Connect both foot pads to their upper and lower stair arm pieces. Secure with two pins for each foot pad.

Use a clip to secure the two C-rings on the opposite side of the foot pad (see Fig. 14 & 15).

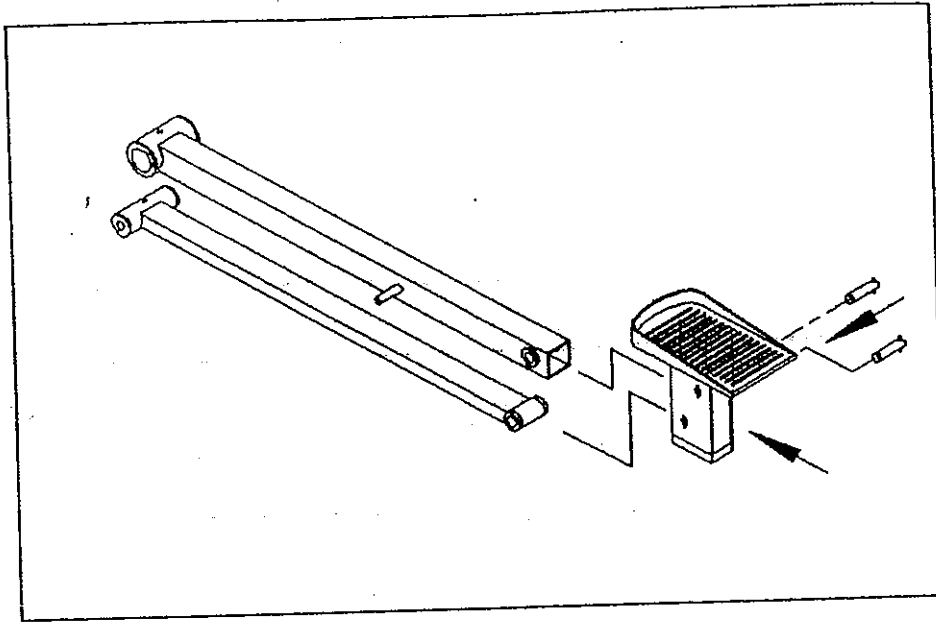

Fig. 14

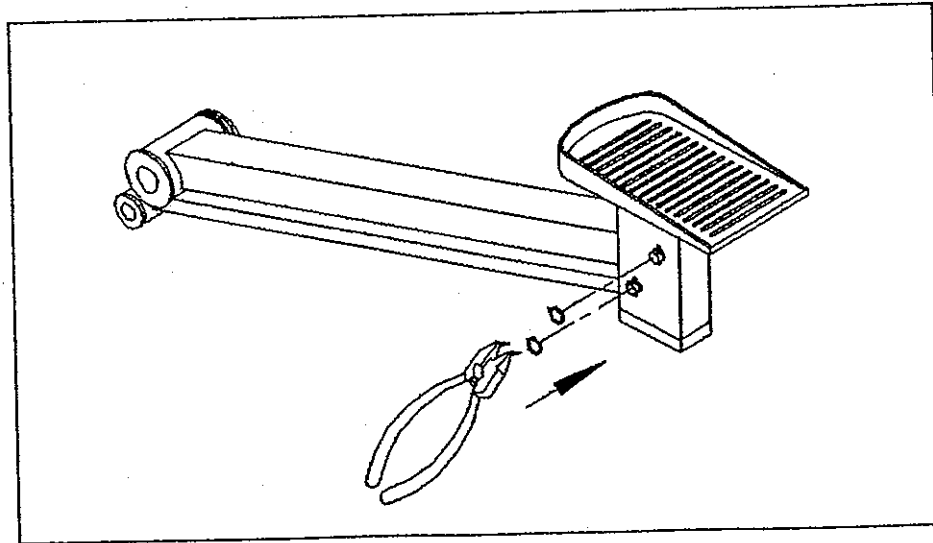

Fig. 15

NOTE: The footpads are not interchangeable. When assembling the footpads, make sure that the side with the longer overhang is on the inside (facing the center) on both sides (please see Fig 15-a). Incorrect assembly will result in a wider than normal foot position.

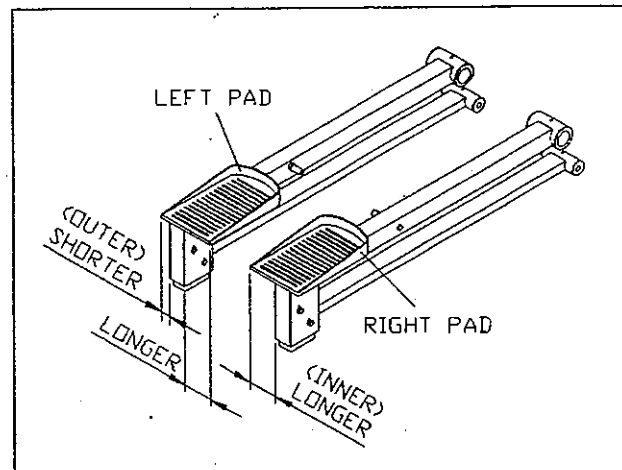

Fig. 15

2. Put the two stair arms into the correct position, making sure both poly-V belt connector shafts are on the inside of the stair arms.

Insert both stair arm shafts into their positions.

Then, secure with 2 screws and 4 washers for each shaft (see Fig. 16).

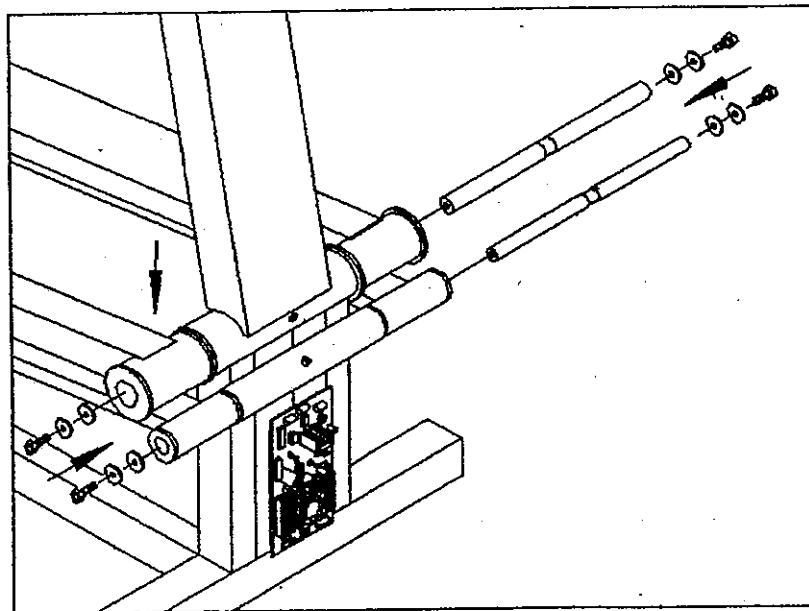

Fig. 16

3. Secure the stair arm shafts with the two screws to lock the shafts in place (see Fig. 17).

NOTE: Do not overtighten these screws.

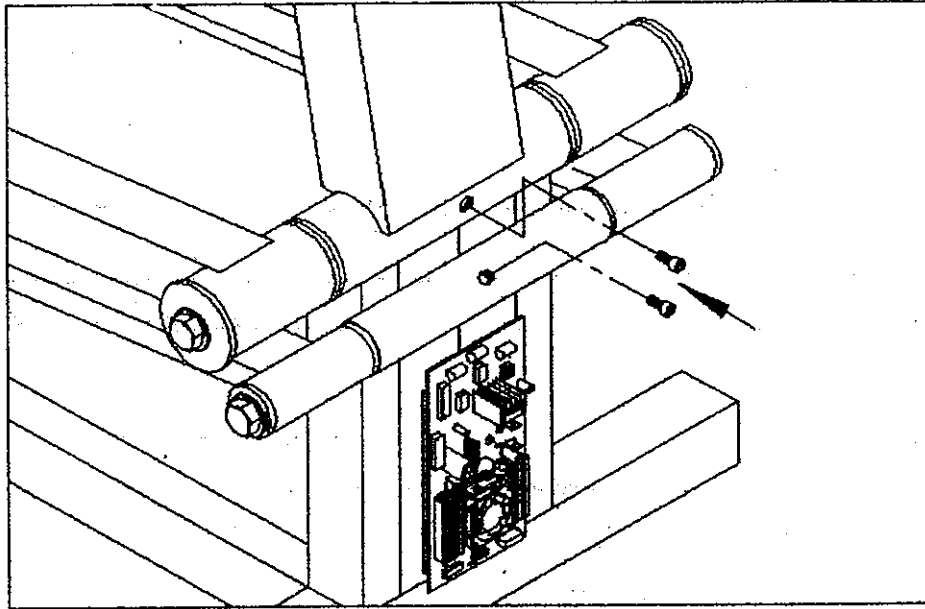

Fig. 17

4. Secure the end of the stair arm belt to its shaft with one screw and one washer on each side (see Fig. 18).

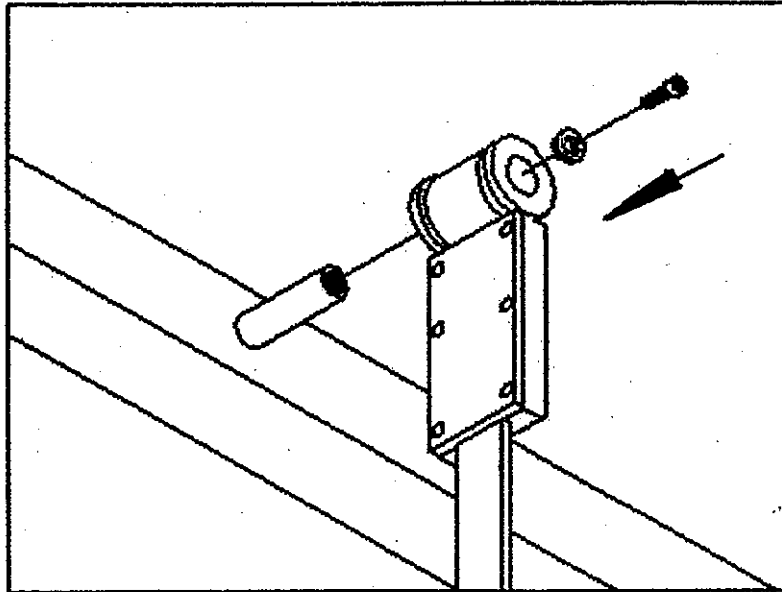

Fig. 18

5. Install the springs (see Fig. 19 to Fig. 19-2).

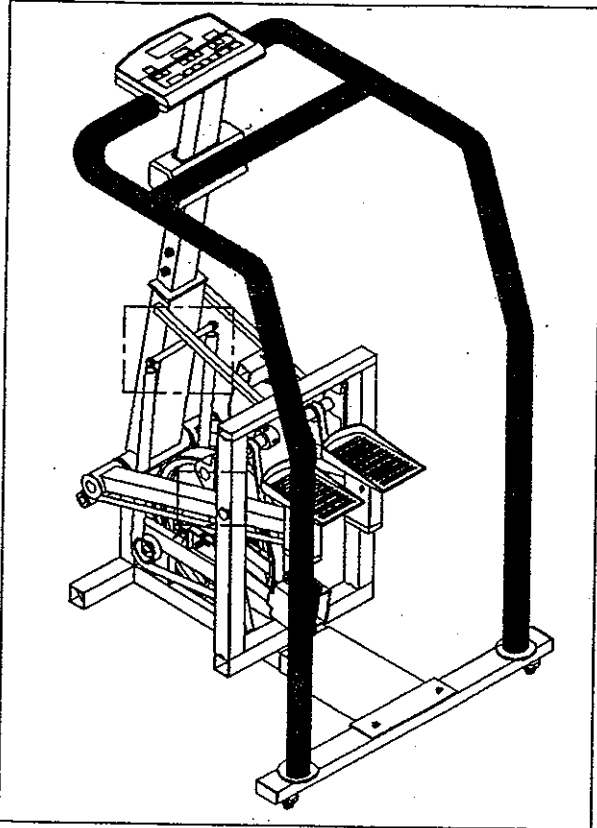

Fig. 19

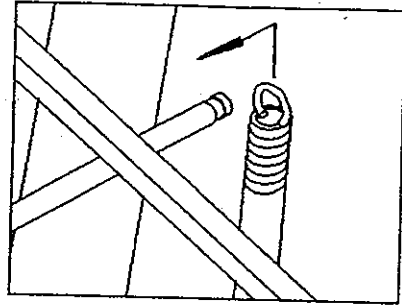

Fig. 19-1

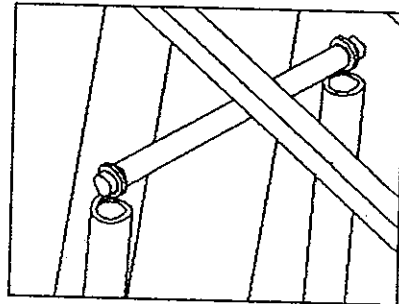

Fig. 19-2

6. Replace the main shroud and secure with screws (see Fig. 20 & 21).

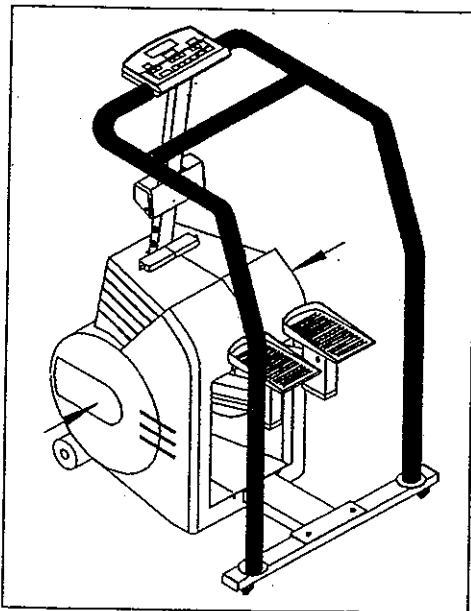

Fig. 20

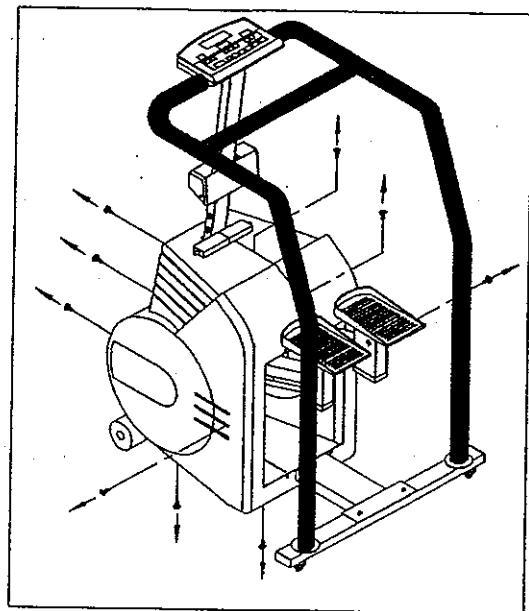

Fig. 21

7. Replace the repair window (see Fig. 22).

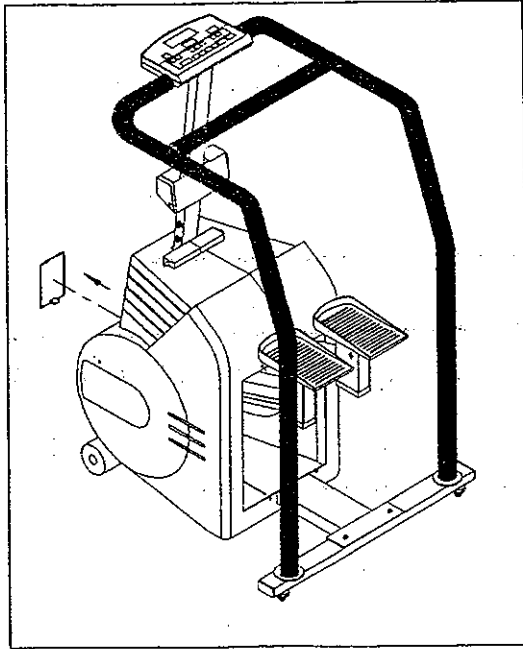

Fig. 22 (7003)

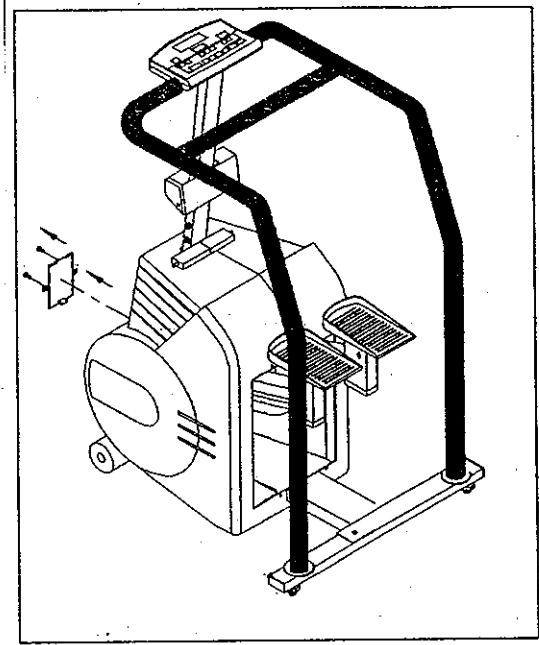

Fig. 22 (7003/7003B/7003C/7003N)

8. Secure the front cover with screws (see Fig. 23).

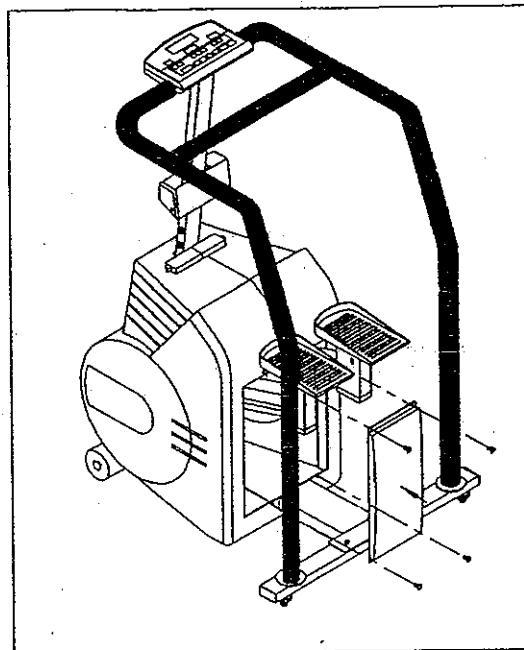

Fig. 23

9. Replace the transport wheels, tighten with screws and washers, then cover with labels (see Fig. 24).

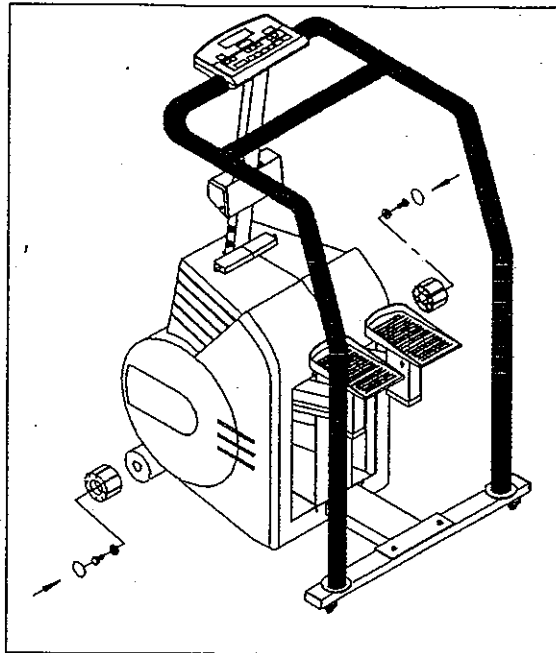

Fig. 24

10. Replace the post shroud, secure with two screws (see Fig. 25 & 26).

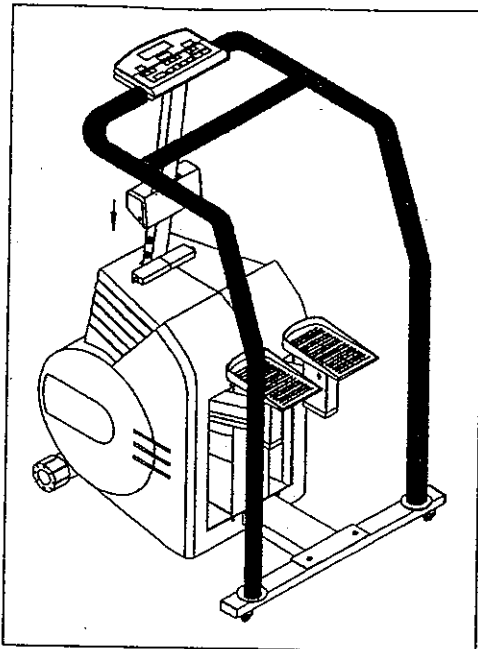

Fig.25

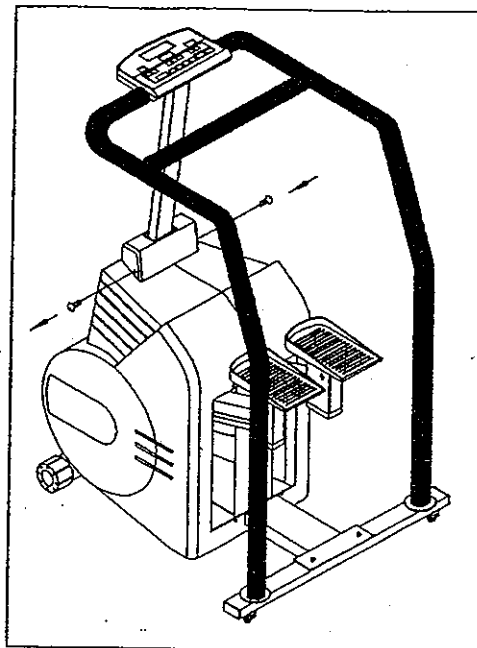

Fig.26

G. ELECTRONICS PACKAGE REMOVAL AND INSTALLATION PROCEDURE

1. Remove the six screws securing the electronics package (see Fig. 1).

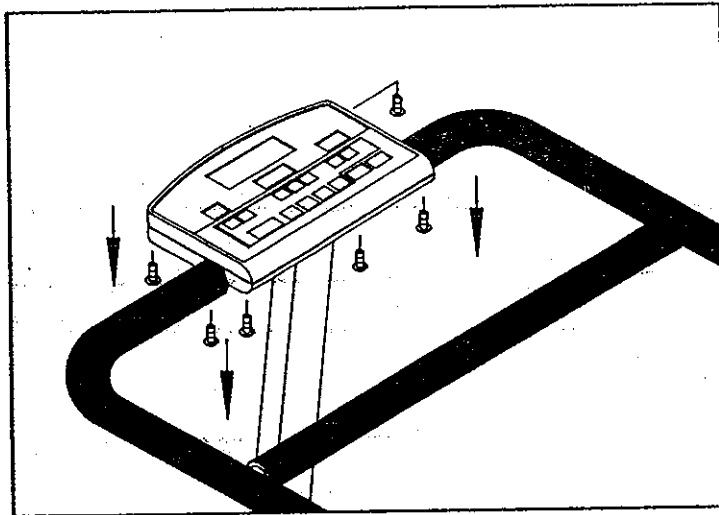

Fig. 1

2. Remove the electronics package, releasing the 16 pin cable connector (A) from its socket in the electronics package.

Note: First pull back the retaining clips to release pressure.

Remove the electronics package (see Fig. 2).

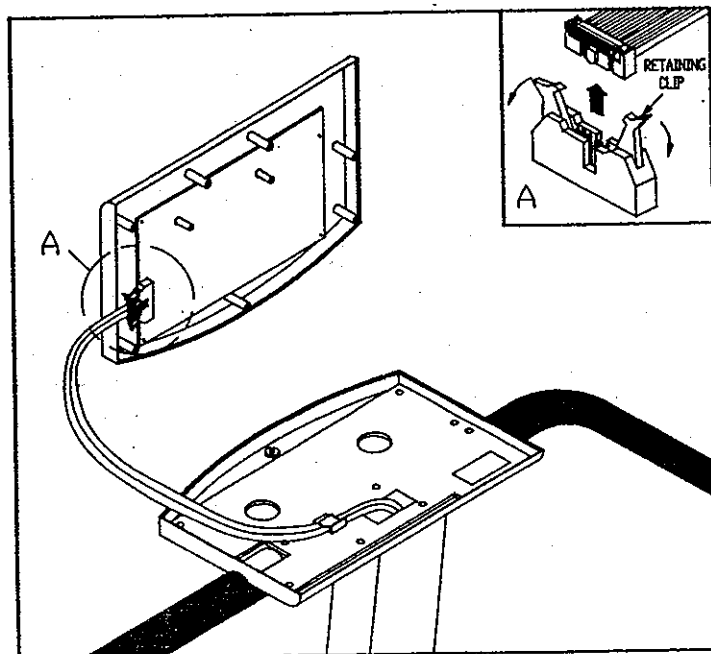

Fig. 2

To install:

1. Install a new electronics package, plug the 16 pin cable connector into its socket and snap the retaining clips to secure (see Fig. 3).

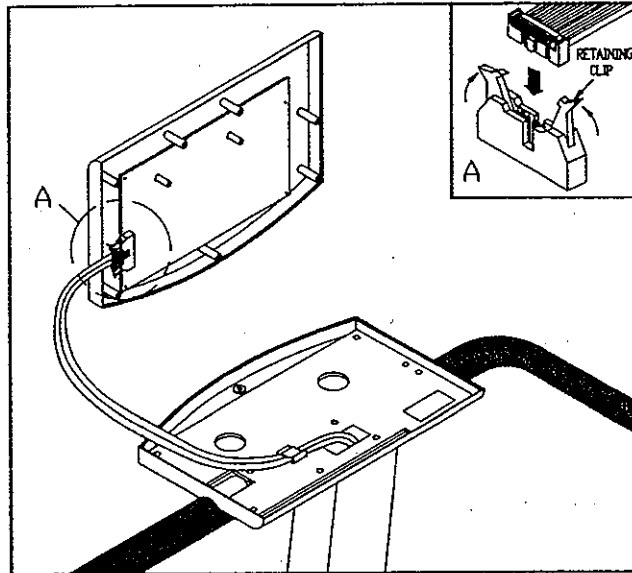

Fig. 3

2. Tighten the six screws securely (see Fig. 4).

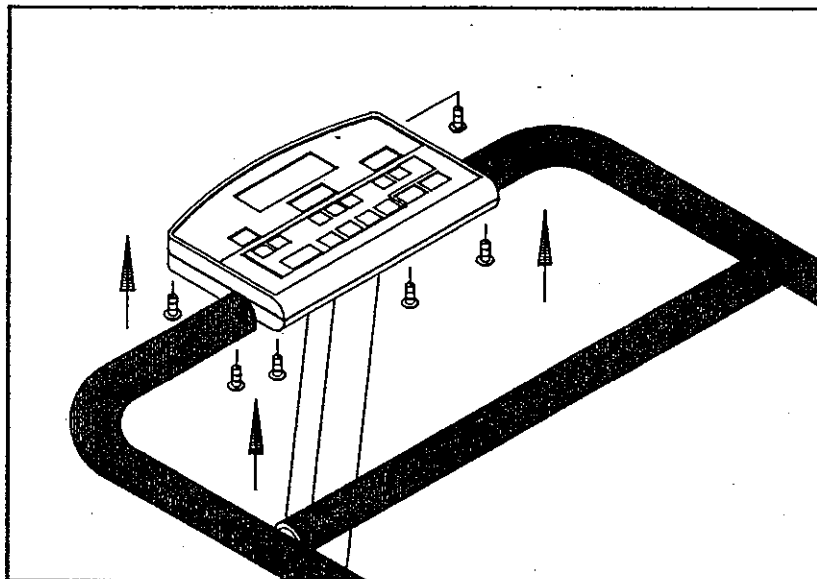

Fig. 4

H. ELECTRONICS PACKAGE 16-PIN CABLE REMOVAL AND INSTALLATION PROCEDURE

1. Remove the six screws securing the electronics package (see Fig. 1).

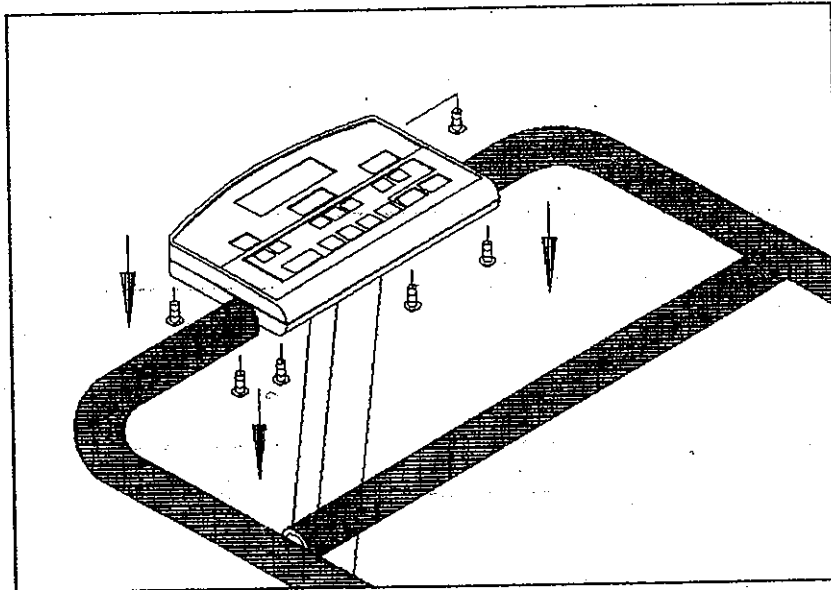

Fig.1

2. Remove the electronics package, releasing the 16 pin cable connector (A) from its socket in the electronics package.

NOTE: First pull back the retaining clips to release pressure. Then, remove the cable from the cable clip (B) located on the base of the electronics package (see Fig. 2).

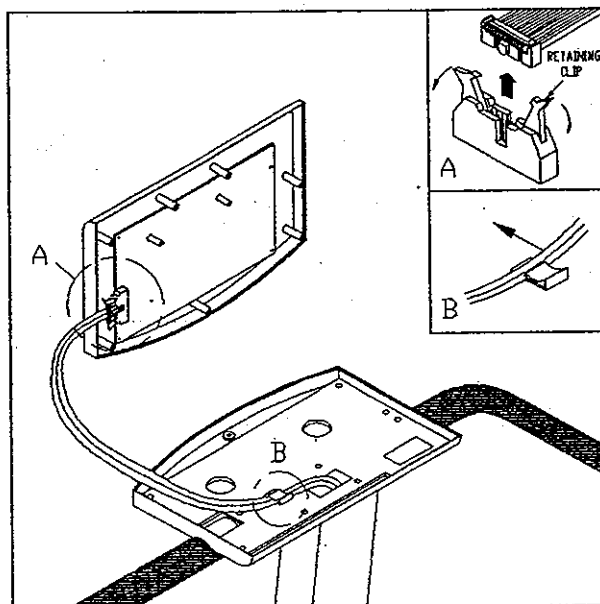

Fig. 2

3. Remove the four screws and washers securing the handlebars to the electronics package.

Remove the two screws and washers securing the cross handlebar.

Remove the two screws and washers securing the handlebars to the rear base. (see Fig. 3)

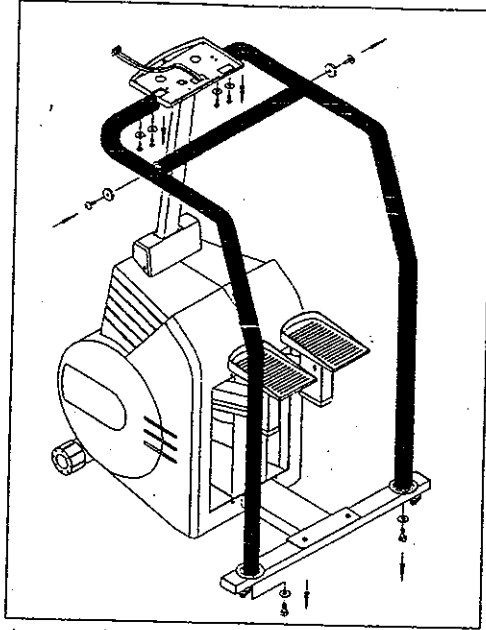

Fig. 3

4. Remove the two screws securing the post shroud (see Fig. 4).

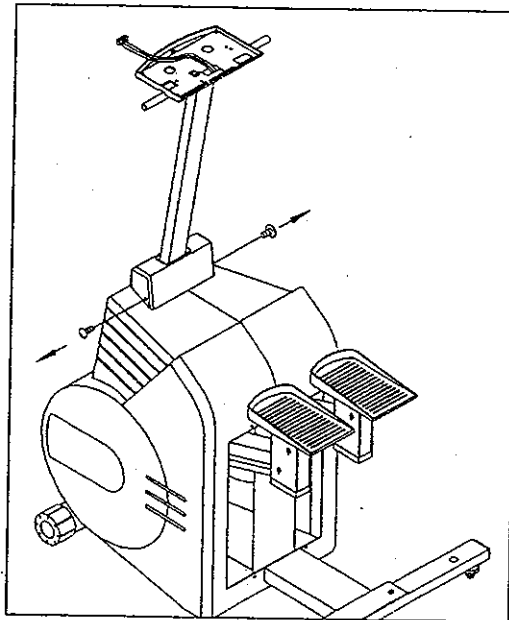

Fig. 4

5. Remove the six screws, spring washers and washers securing the front post (see Fig. 5).

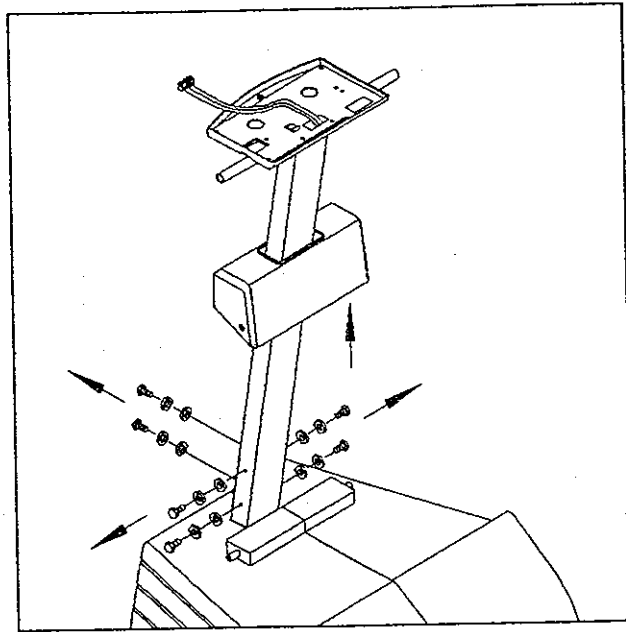

Fig. 5

6. Release the 16 pin cable from its socket in the terminal, first pulling back the retaining clips. Then, remove the cable (see Fig. 6).

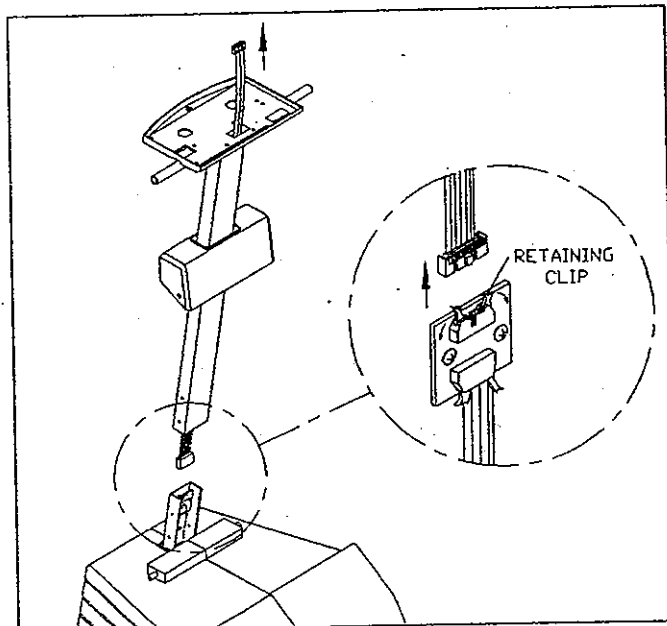

Fig. 6

To install:

1. Replace a new 16 pin cable inside the front post, threading the cable through the front post.

Insert the 16 pin cable into the upper socket on the terminal and snap the retaining clips to apply pressure. Fasten the cable into the cable clip (see Fig. 7) on the electronics package base.

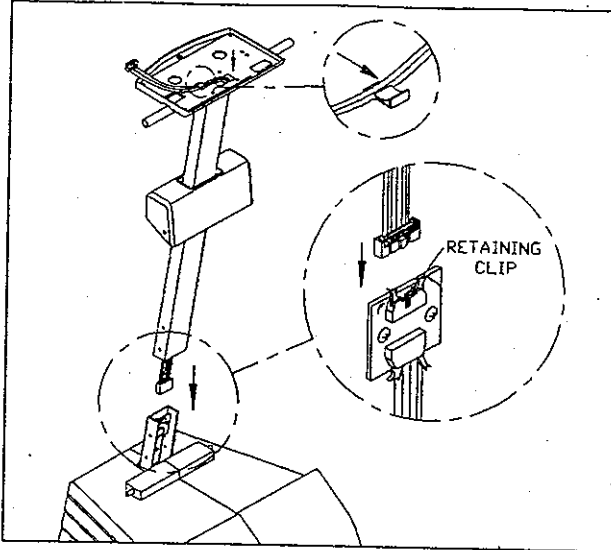

Fig. 7

2. Insert the front post into the main frame, and secure with the six screws, spring washers and washers (see Fig. 8).

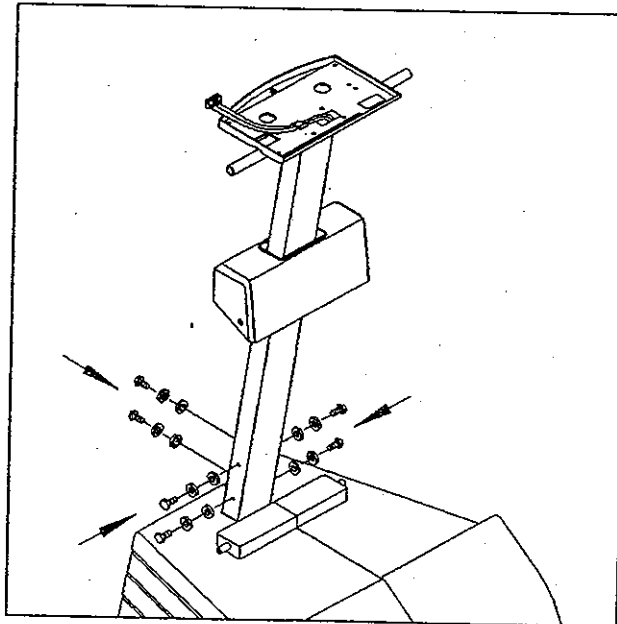

Fig. 8

3. Slide the post shroud down into place, and secure with two screws (see Fig. 9).

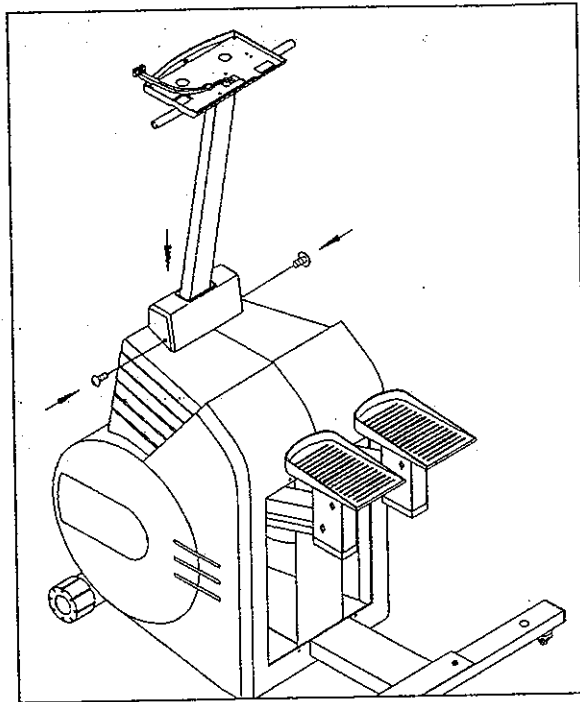

Fig. 9

4. Plug the cable connector into its socket on the electronics package (see Fig. 10).

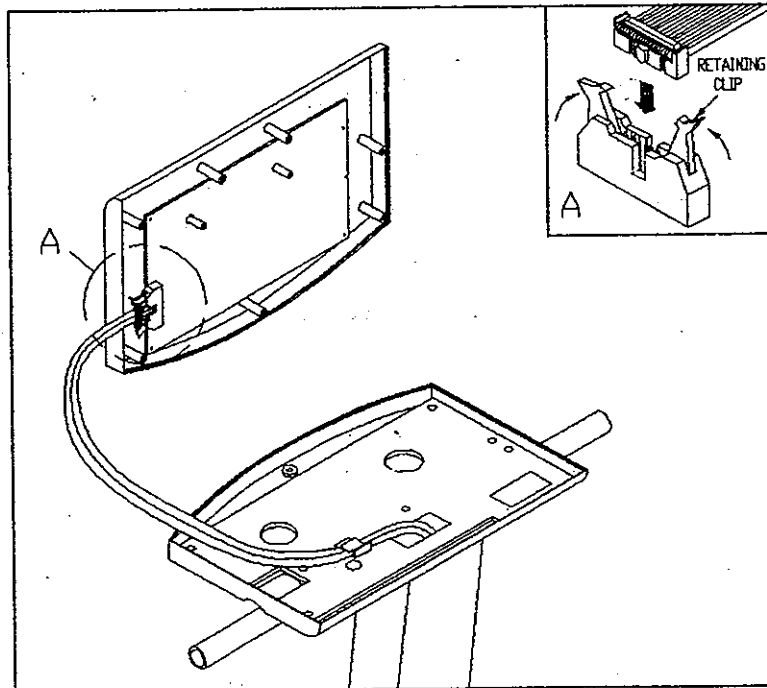

Fig. 10

5. Replace the electronics package, then tighten securely (see Fig. 11).

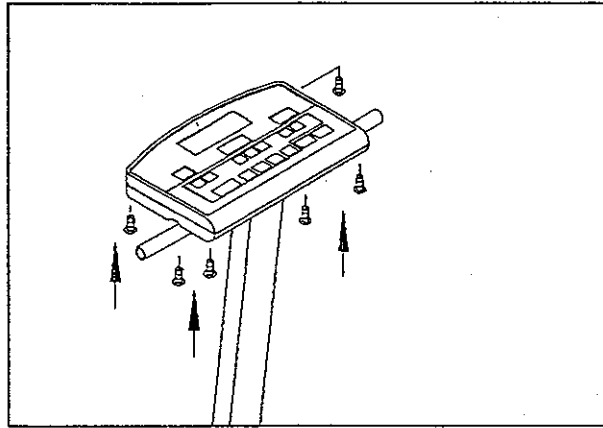

Fig. 11

6. Insert the bottom handrails into the rear base and the upper handrails to the electronics package. DO NOT TIGHTEN YET.

Assemble the cross handlebar and secure with screws and washers.
Now, tighten all the screws (see Fig. 12).

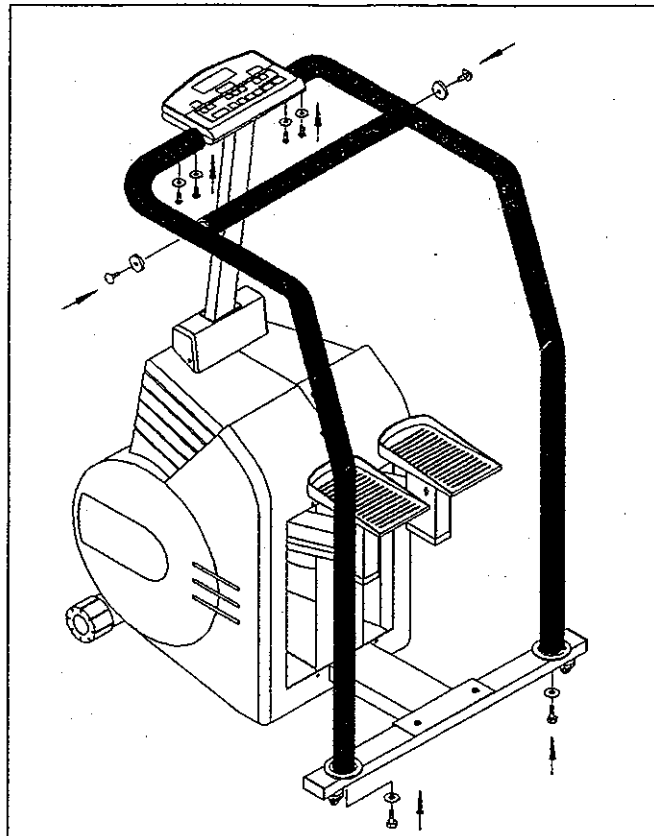

Fig. 12

I. DRIVE BOARD REMOVAL AND INSTALLATION PROCEDURE

1. Remove the repair window, locate the drive board inside the frame (see Fig. 1 & 2).

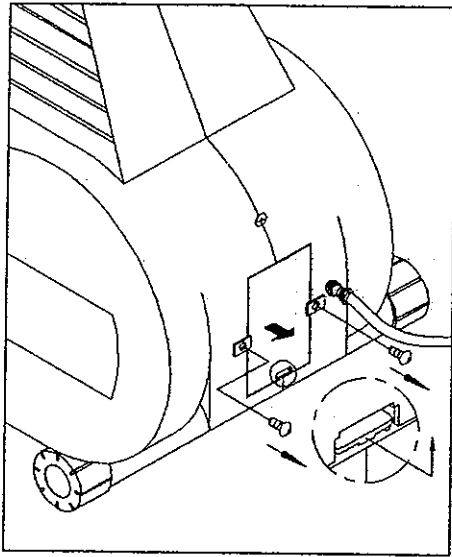

Fig 1. (7003/7003B/7003C/7003N)

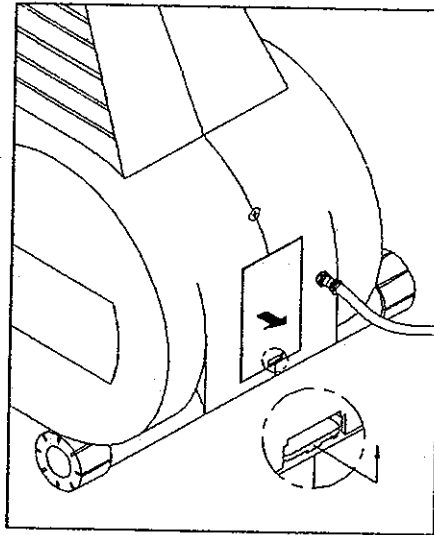

Fig 1. (7003)

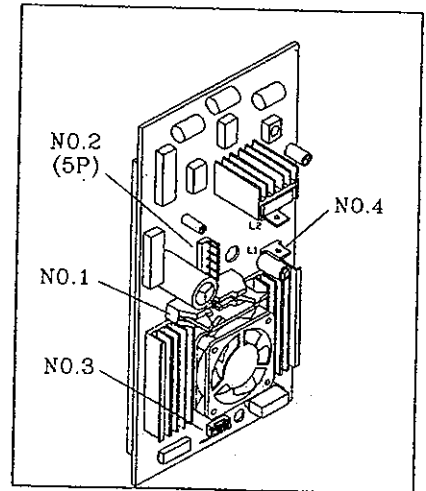

Fig 2.

2. Release the 16 pin (No. 1) cable from its socket. First pull back the retaining clips to release the cable (see Fig. 2 & 3).

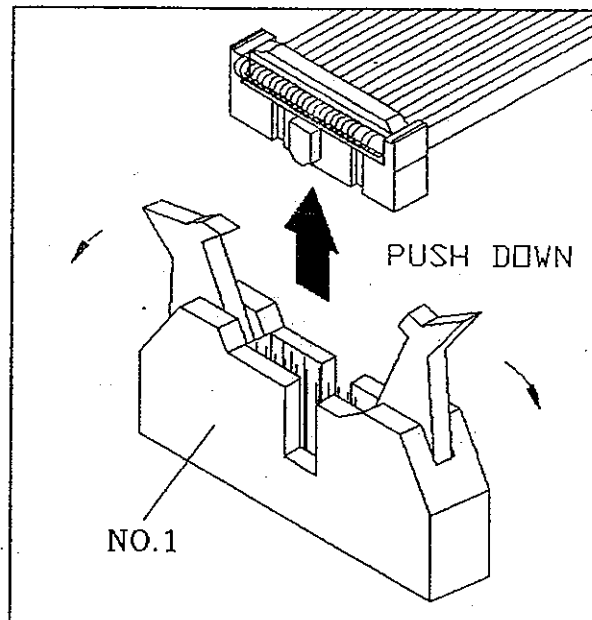

Fig. 3

3. Remove wiring harness No. 3 and then No. 2 by depressing the tab and pulling (see Fig. 2, 4 & 5).

Warning: DO NOT pull by the wire --damage may result.

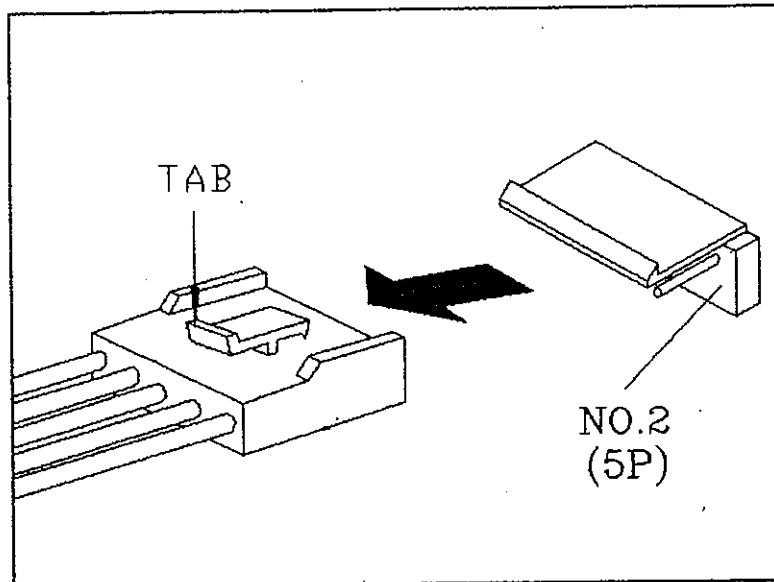

Fig. 4

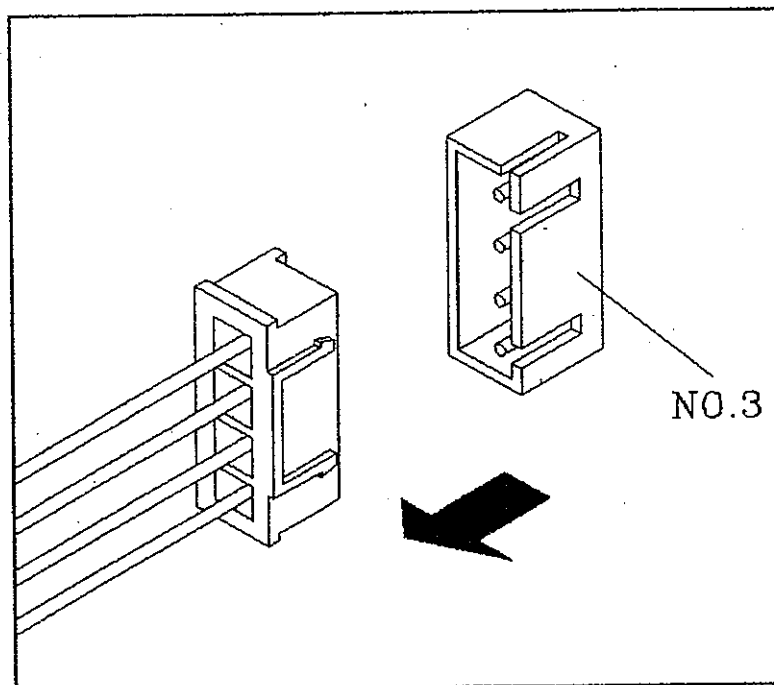

Fig. 5

4. Remove the two No. 4 blue wires from the L1 & L2 sockets (see Fig. 2 & 6).

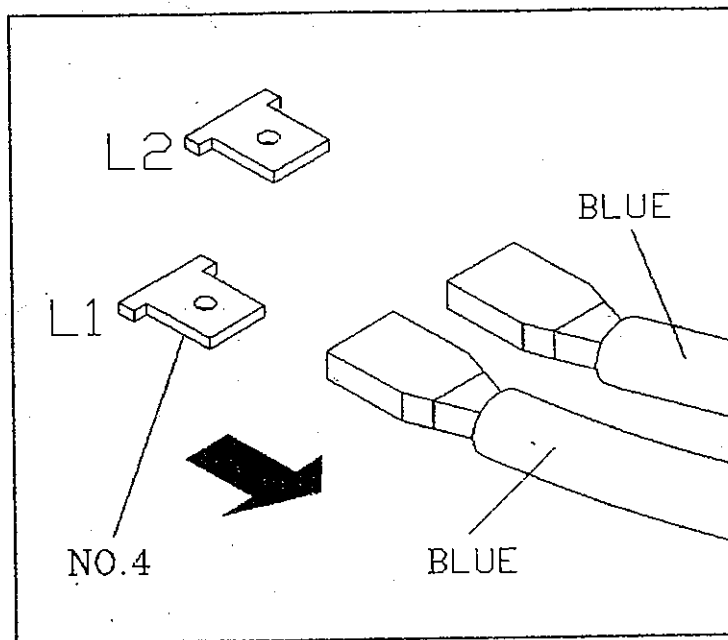

Fig. 6

5. Remove the two screws securing the drive board and remove it (see Fig. 7 & 8)

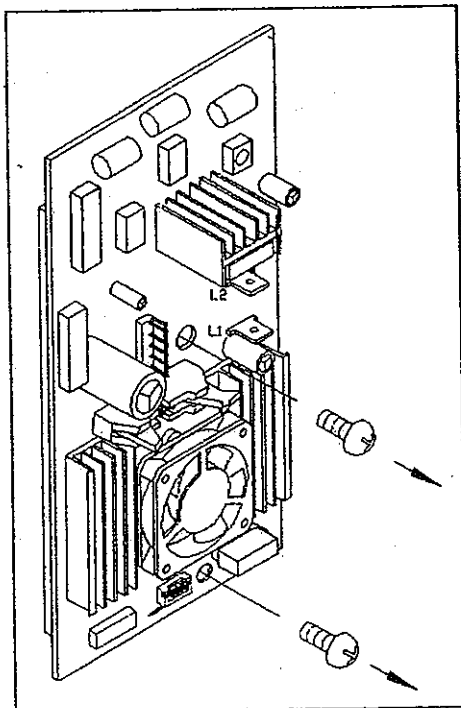

Fig. 7

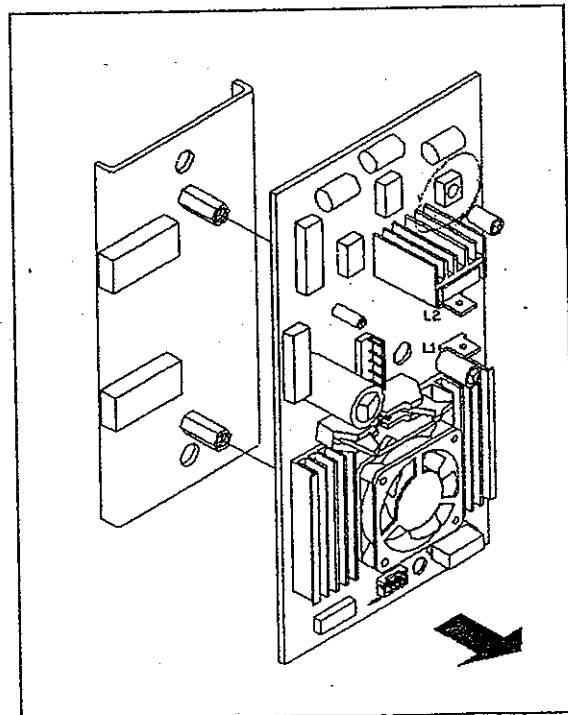

Fig. 8

To install:

1. Place a new drive board into the front of the machine. Secure with two screws (see Fig. 9 & 10).

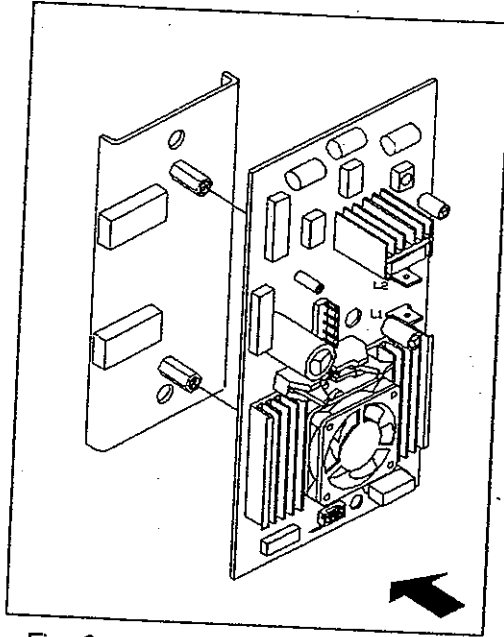

Fig. 9

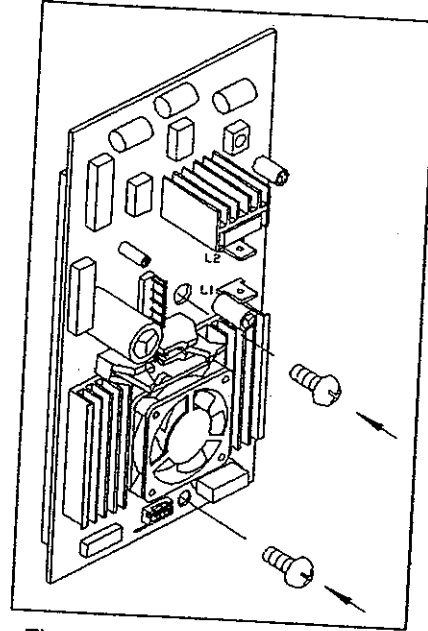

Fig. 10

2. Insert the No. 3 wire harness into its socket (see Fig. 2 & 11).

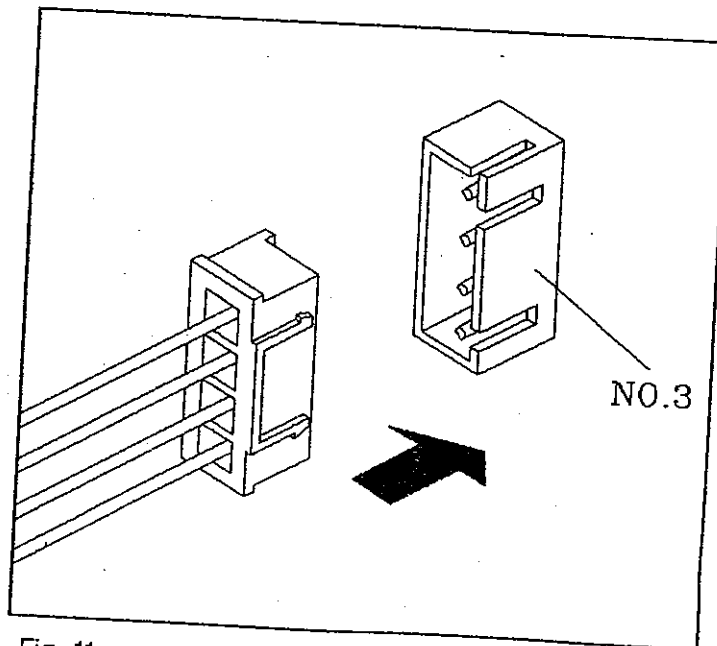

Fig. 11

3. Insert the two No. 4 blue wire connectors into the L1 & L2 sockets (see Fig. 2 & 12).

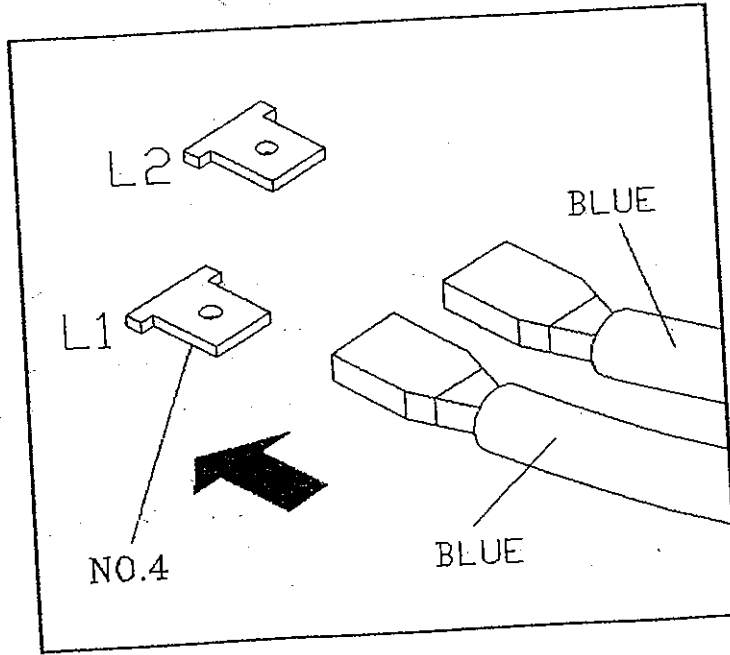

Fig. 12

4. Insert the No. 2 wire connector into its socket (see Fig. 2- & 13).

NOTE: Apply downward pressure to the tab while inserting.

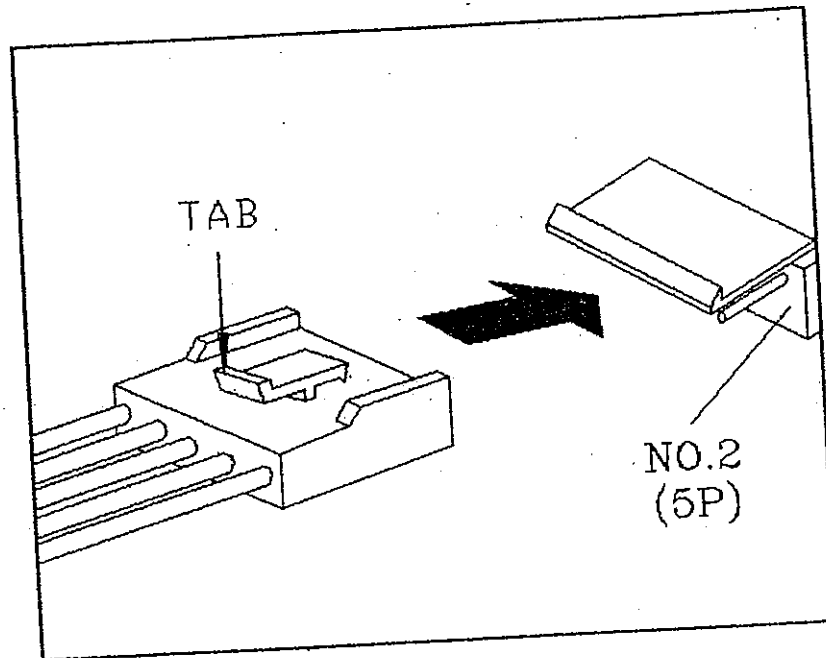

Fig. 13

5. Insert the 16 pin (No. 1) cable into its socket and snap the retaining clips to hold in place (see Fig. 2 & 14).

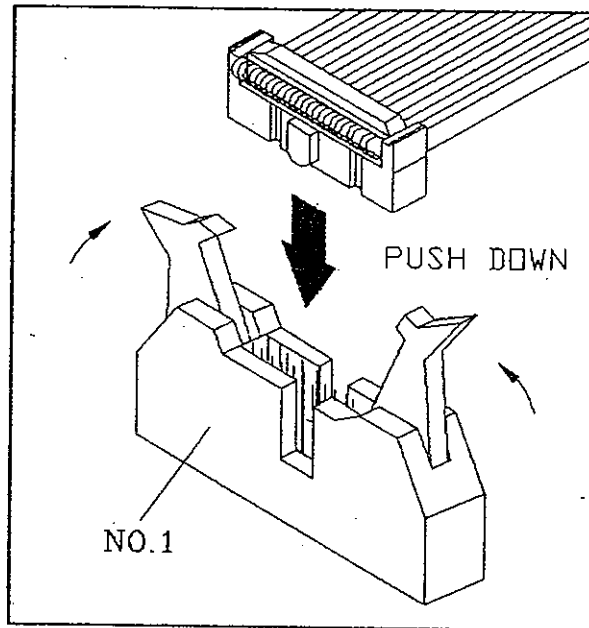

Fig. 14

6. Please go through a visual inspection to ensure that all wires are in their proper places and secure. Use the cable clip to tighten up and hold all the cables together (see Fig. 15).

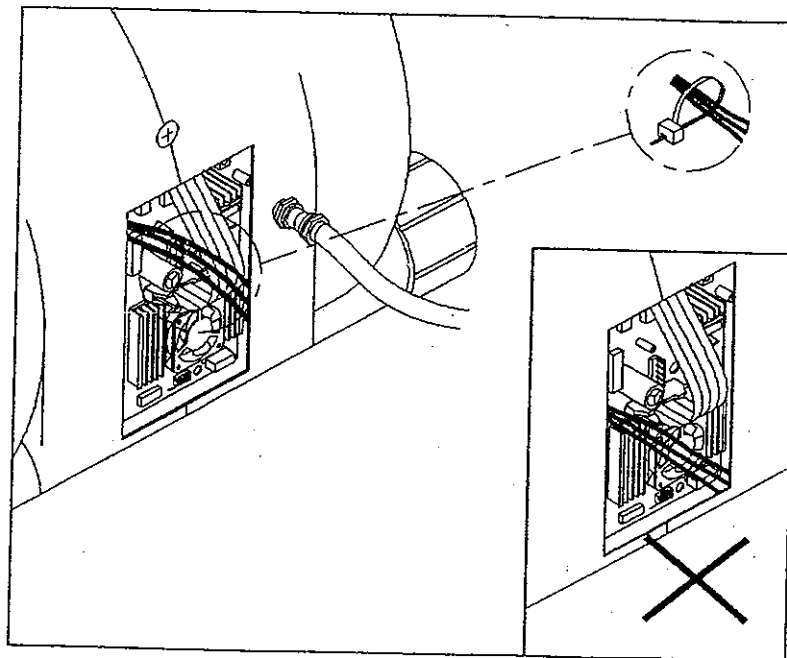

Fig. 15

7. Place the repair window back into position, follow the steps as shown in the Fig. 16 & 17.

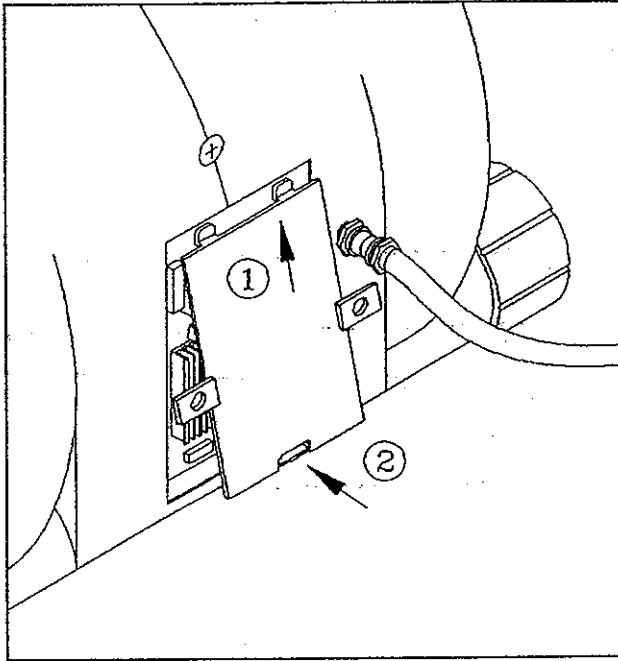

Fig 16. (7003/7003B/7003C/7003N)

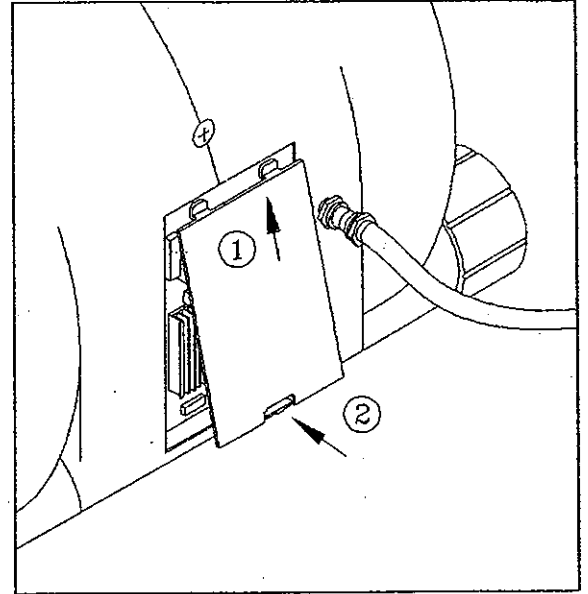

Fig 16. (7003)

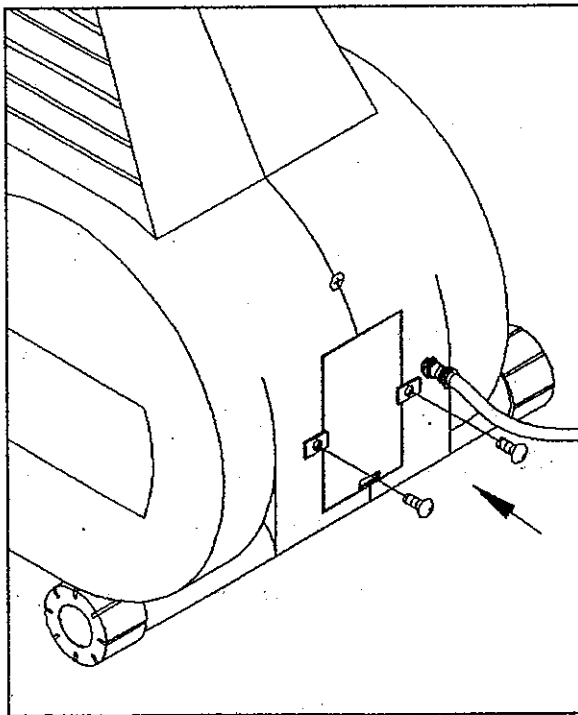

Fig 17. (7003/7003B/7003C/7003N)

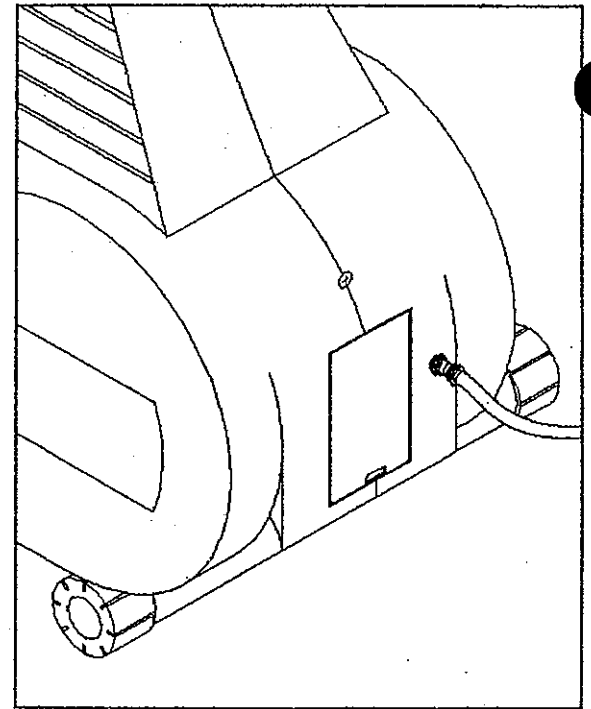

Fig 17. (7003)

J. DRIVE BOARD 16 PIN CABLE REMOVAL AND INSTALLATION PROCEDURE

1. Remove all the screws securing handlebars and rear base (see Fig. 1).

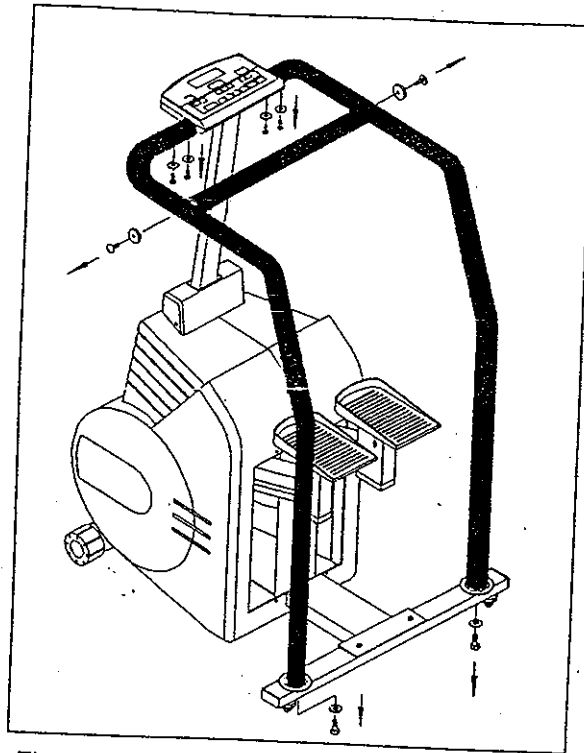

Fig.1

2. Unscrew two screws securing the post shroud (see Fig. 2).

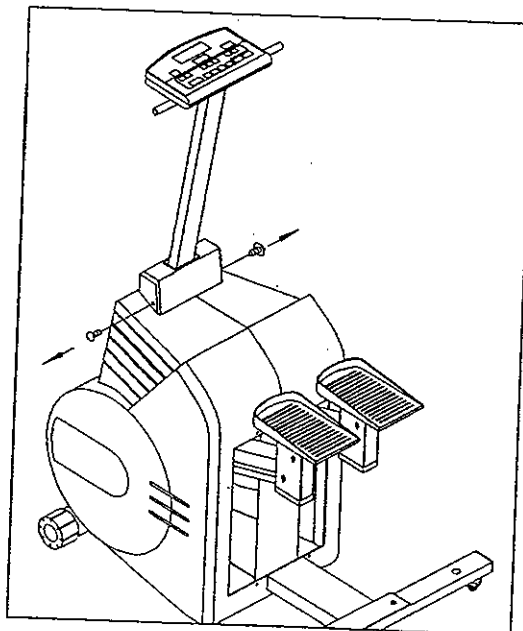

Fig. 2

3. Push the post shroud up and then unscrew all the screws and washers securing the front post (see Fig. 3).

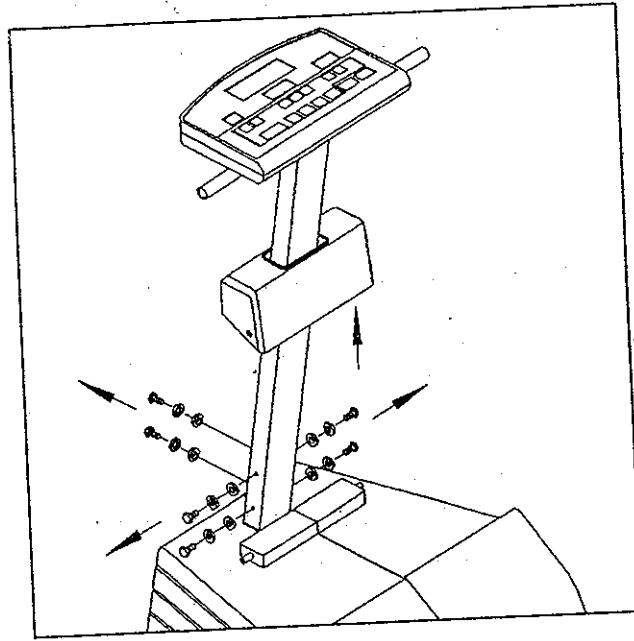

Fig. 3

4. Remove the front post, first pulling back the retaining clips, then release the cable from the upper socket on the terminal.

Pull back the retaining clips on the terminal's lower socket to release the drive board 16 pin cable. (see Fig. 4)

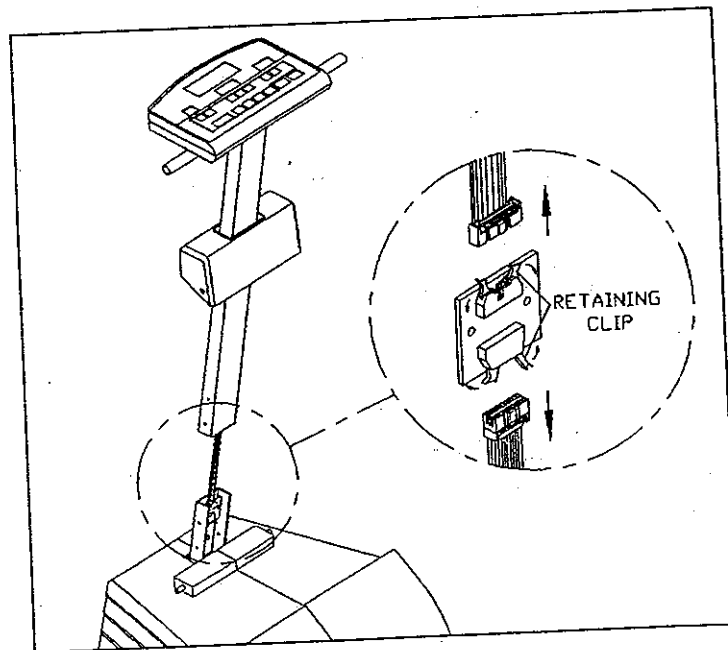

Fig. 4

5. Open the repair window (see Fig. 5).

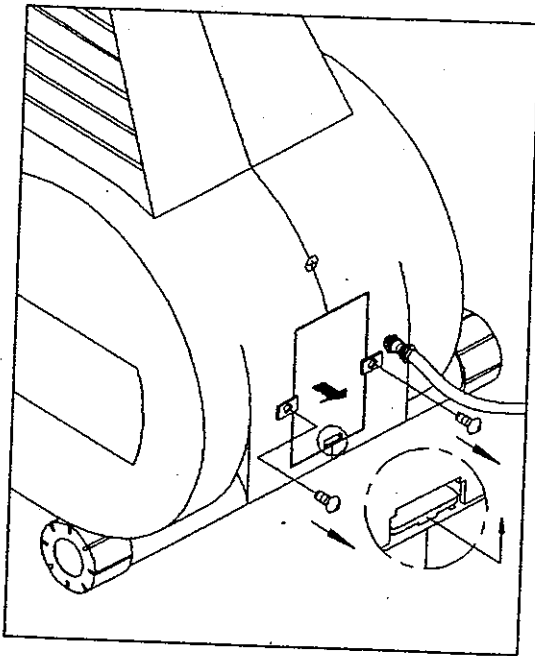

Fig 5. (7003/7003B/7003C/7003N)

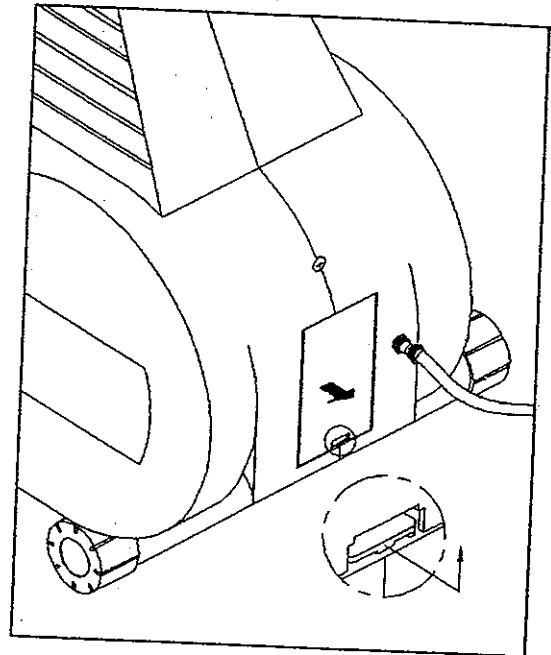

Fig 5. (7003)

6. Unplug the 16 pin cable, pull back the retaining clips to release the pressure (see Fig. 6). Remove the 16 pin cable.

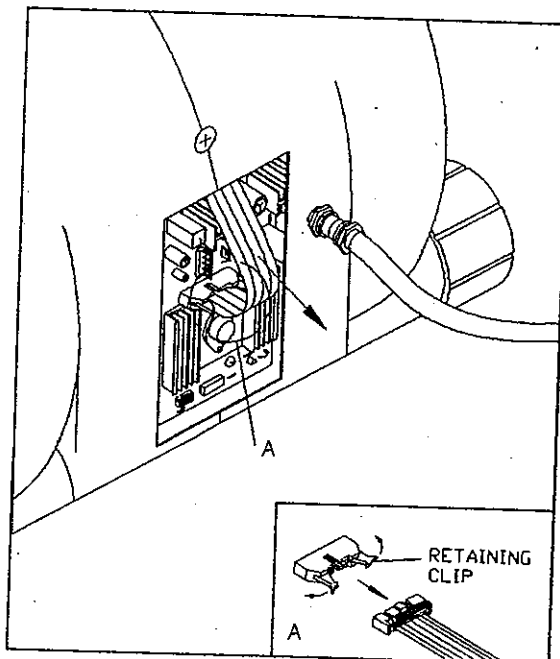

Fig. 6

To install:

1. Insert the new 16 pin cable into the lower socket on the terminal, snap retaining clips to hold in place. Then thread the cable through the shroud.

Plug the electronics package 16 pin cable into the upper socket on the terminal, snap retaining clips to hold in place (see Fig. 7).

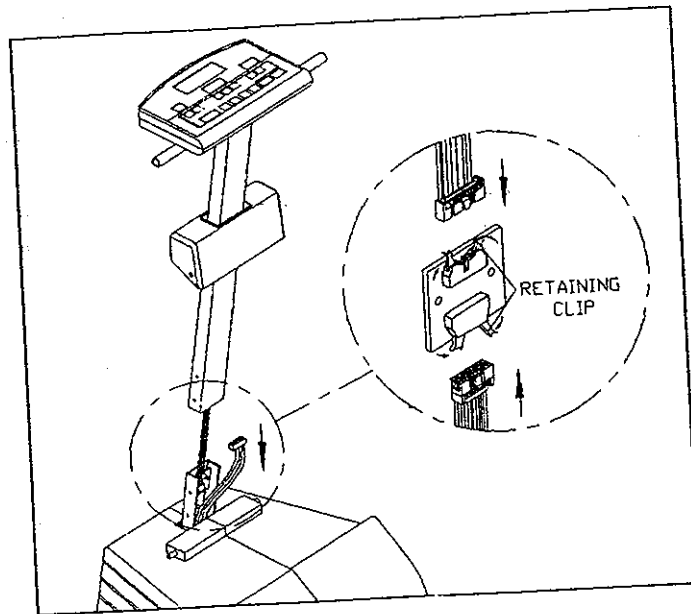

Fig. 7

2. Assemble the front post and tighten all the screws and washers (see Fig. 8).

3. Secure the post shroud with two screws (see Fig. 9).

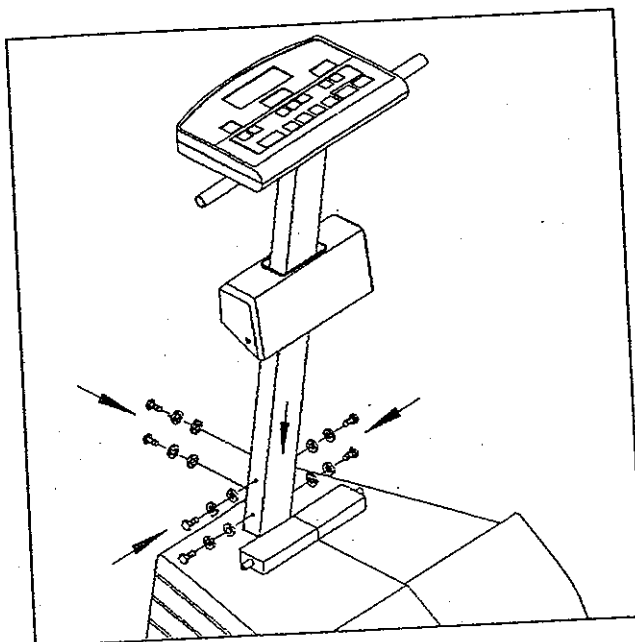

Fig. 8

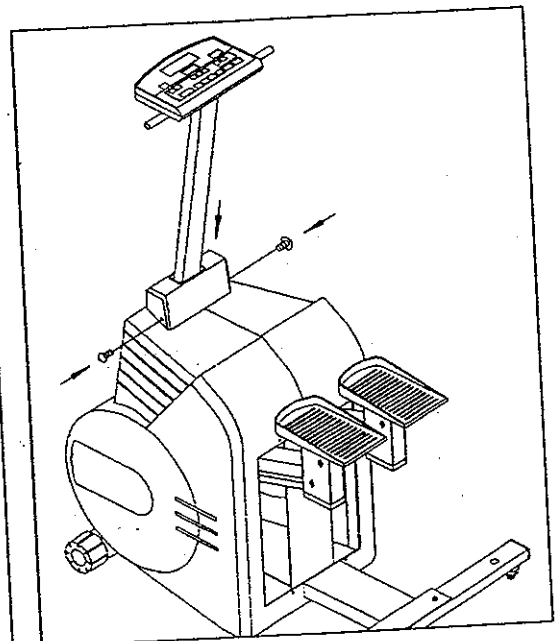

Fig. 9

4. Plug the 16 cable connector into its socket on drive board, snap the retaining clips to secure the cable (see Fig. 10).

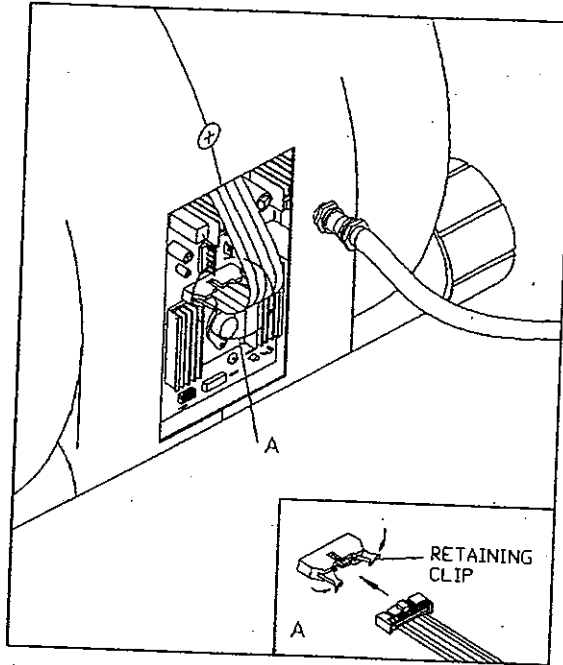

Fig. 10

5. Replace the repair window (see Fig. 11).

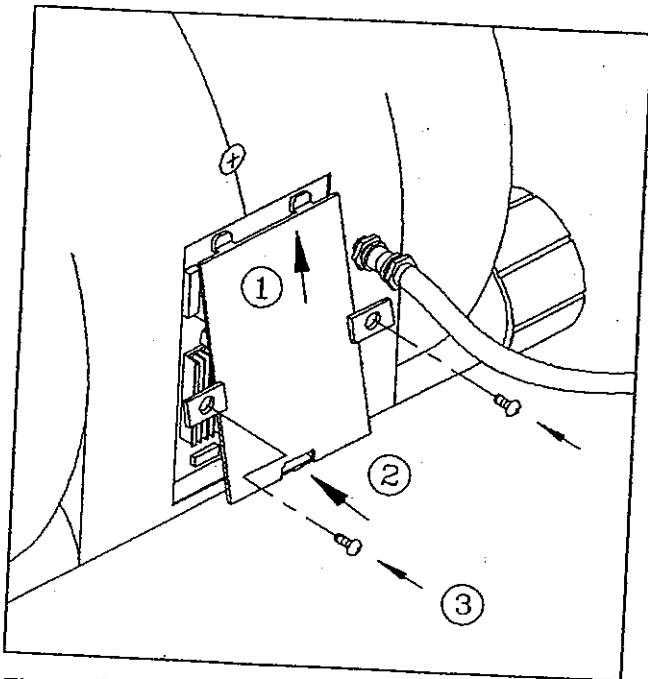

Fig 11. (7003/7003B/7003C/7003N)

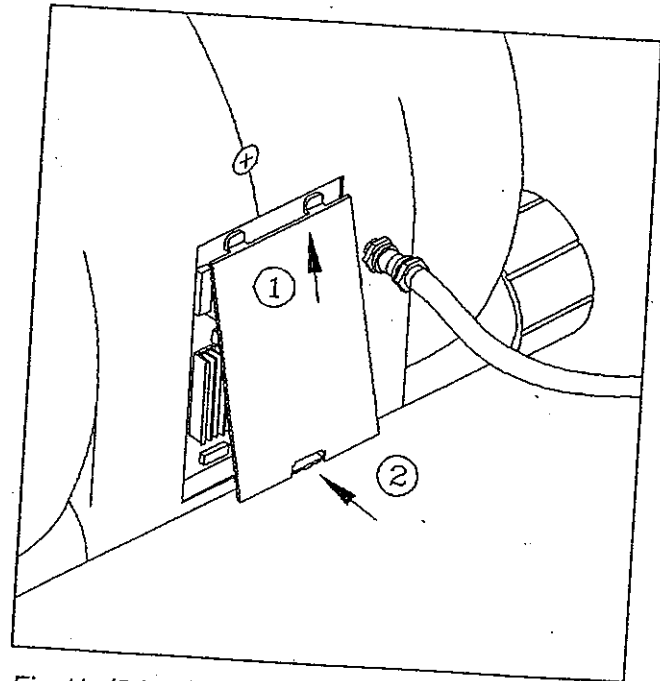

Fig 11. (7003)

6. Insert the bottom handrails into the rear base and the upper handrails to the electronics package. **DO NOT TIGHTEN YET.**

Assemble the cross handlebar to the front of the handrail and secure with screws and washers.

Now, tighten all the screws (see Fig. 12).

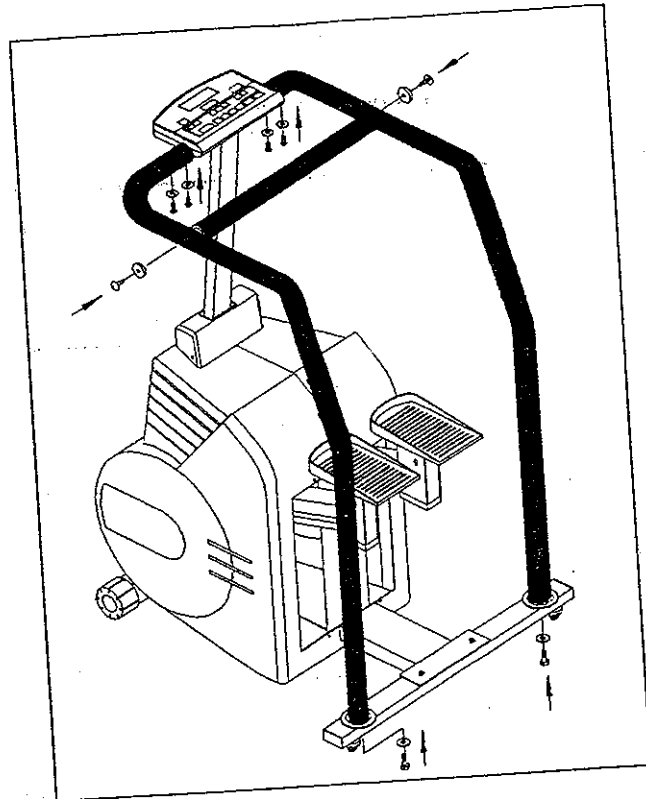

Fig. 12

K. EDDY CURRENT SYSTEM REMOVAL AND INSTALLATION PROCEDURE

1. Remove the two screws securing the post shroud (see Fig. 1 & 2).

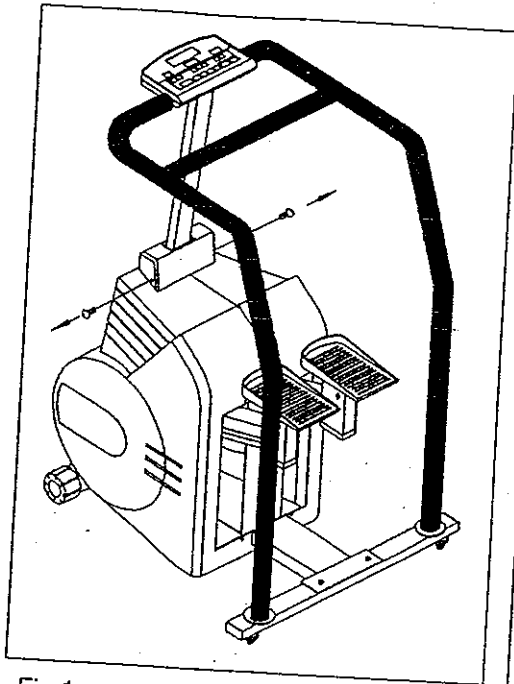

Fig. 1

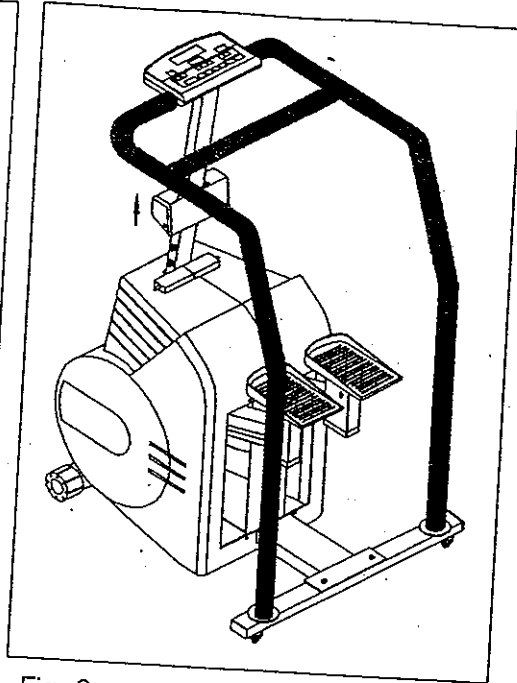

Fig. 2

2. Remove the transport wheel labels first, then unscrew the transport wheels on the front of the stair climber. Remove both wheels (see Fig. 3).

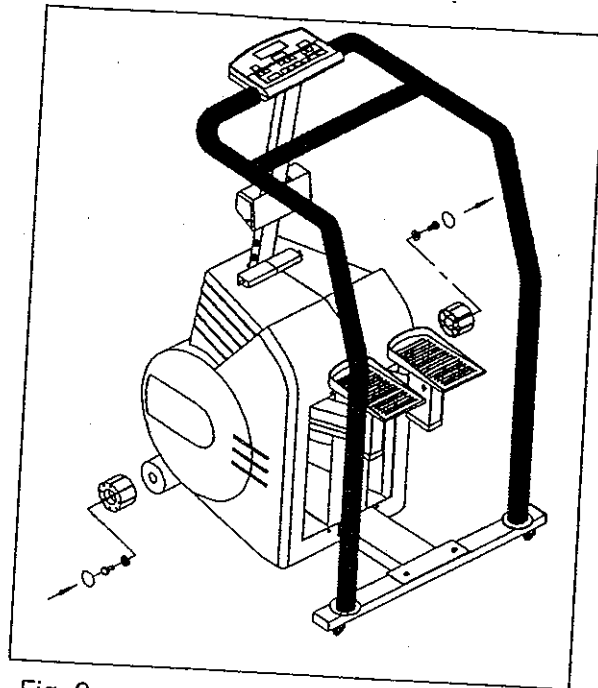

Fig. 3

3. Remove the four screws securing the front cover. (see Fig. 4).

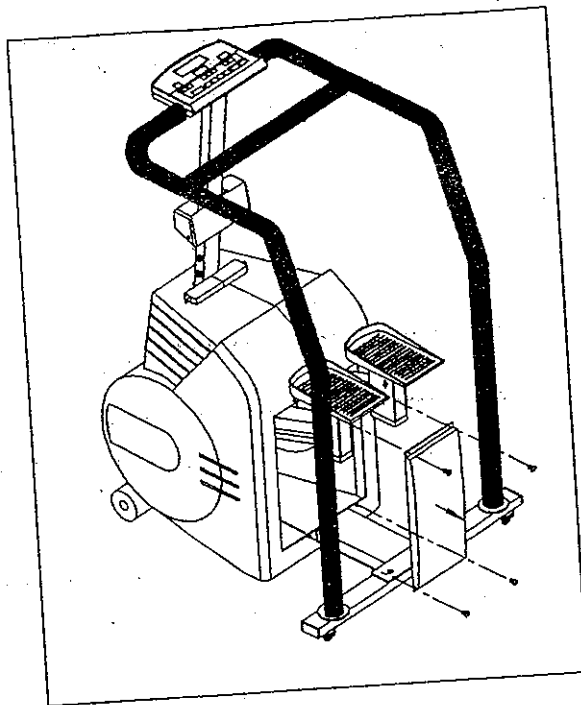

Fig. 4

4. Remove the repair window (see Fig. 5).

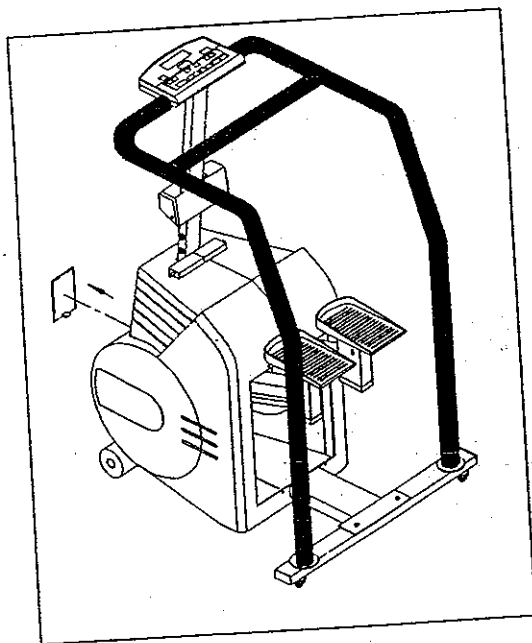

Fig 5. (7003)

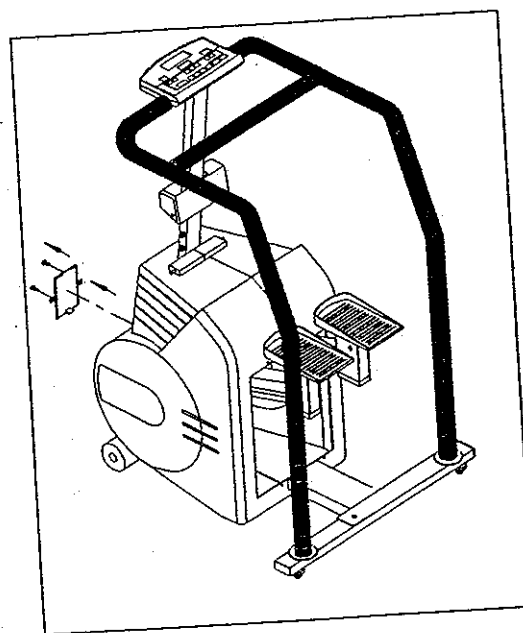

Fig 5. (7003/7003B/7003C/7003N)

5. Remove the nine screws securing the main shroud (see Fig. 6).

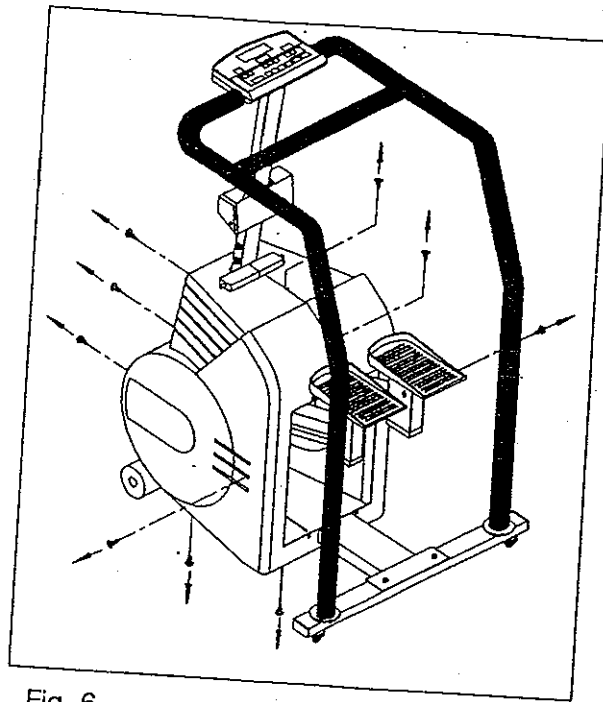

Fig. 6

6. Remove the main shroud (see Fig. 7).

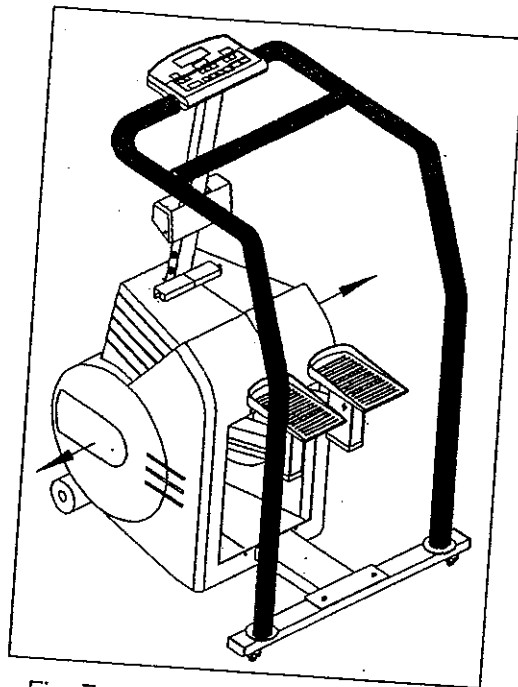

Fig. 7

7. Turn the left nut (located on the left main frame) counterclockwise to release, then remove the fitted washer (see Fig. 8).

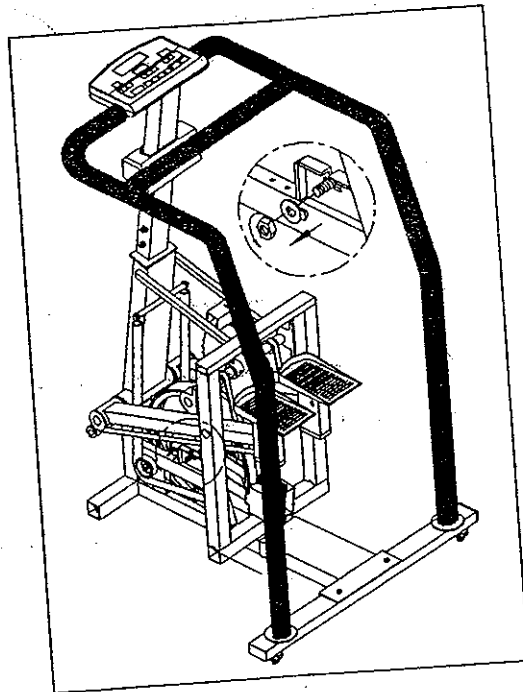

Fig. 8

8. Turn the right nut (located on the right main frame) counterclockwise to release, then remove the fitted washer.

Unscrew the two screws securing the optical switch (see Fig. 9).

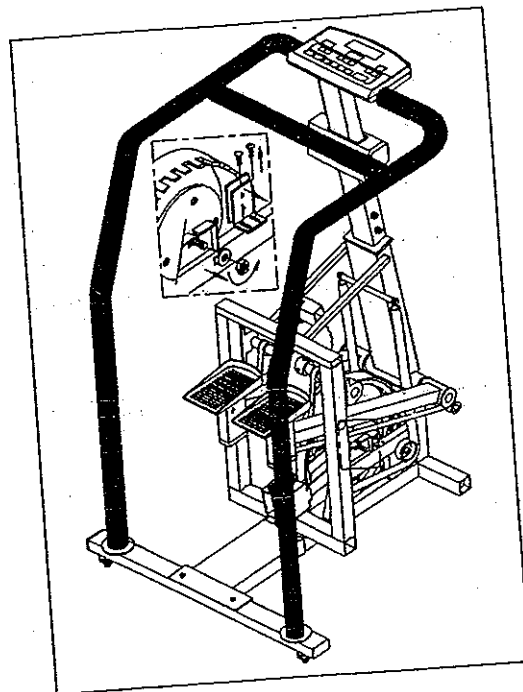

Fig. 9

9. Remove the screw and washer securing the electromagnet unit (see Fig. 10).

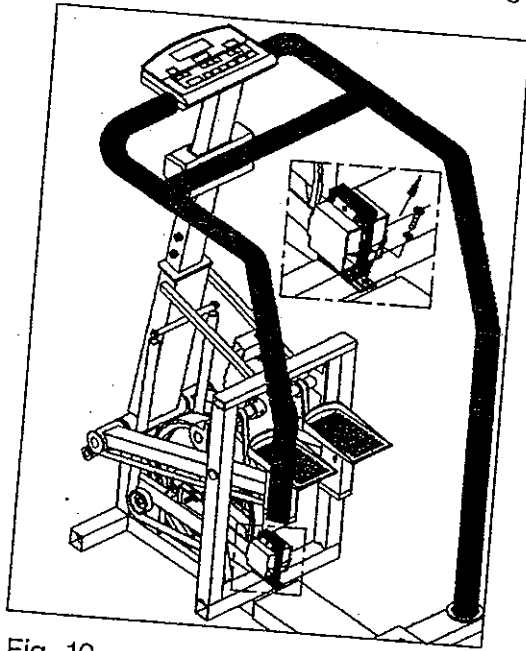

Fig. 10

For 7003 & 7003C

10. Find the chain connector, use a clip to remove the chain connector. Then remove the disconnected chain (see Fig. 11-1 to 11-3).

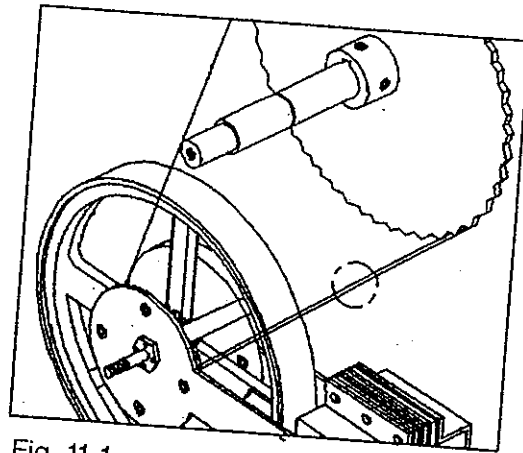

Fig. 11-1

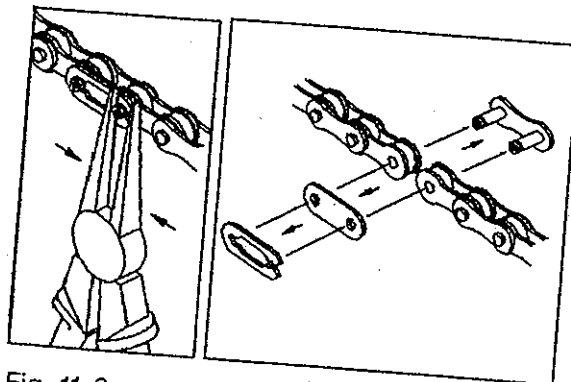

Fig. 11-2

Fig. 11-3

For 7003B & 7003N

10. Raise up the SPRINGS to release both sides, following steps A and B (see Fig. 11A-1).

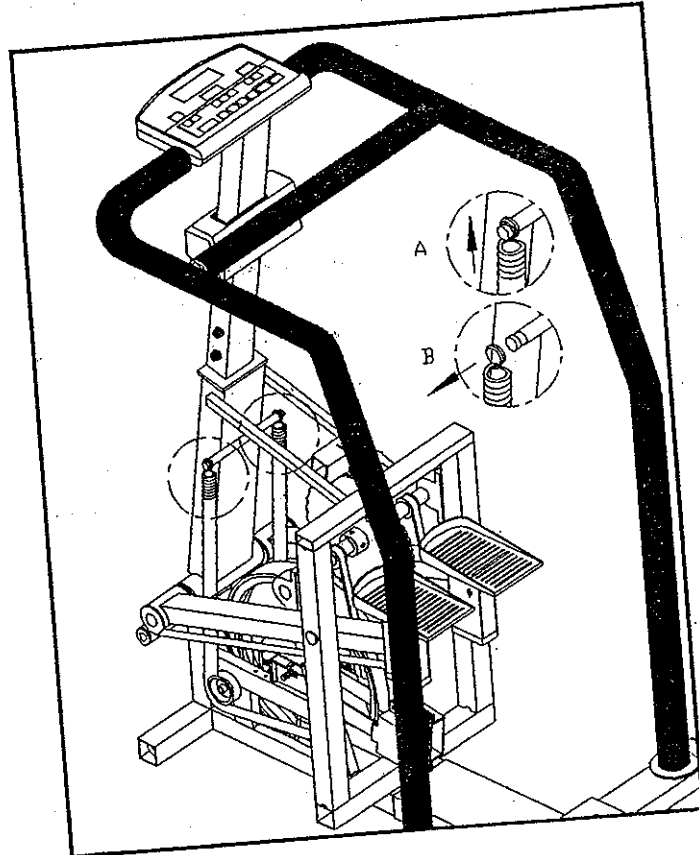

Fig.11A-1

10-1 Lower the foot pads to their lowest position, then slide out the SPRINGS (see Fig. 11A-2).

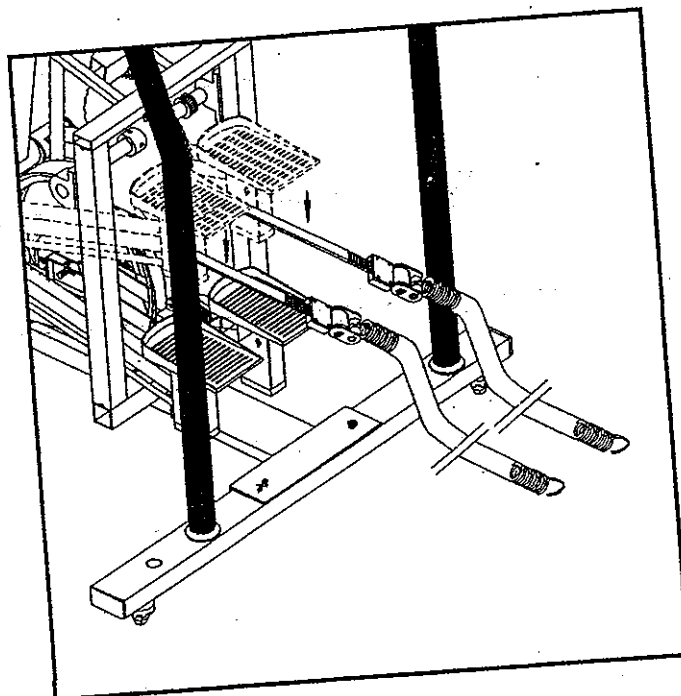

Fig.11A-2

10-2. Remove the two screws and washers securing the bearing (pillow block) on each side (see Fig. 11A-3).

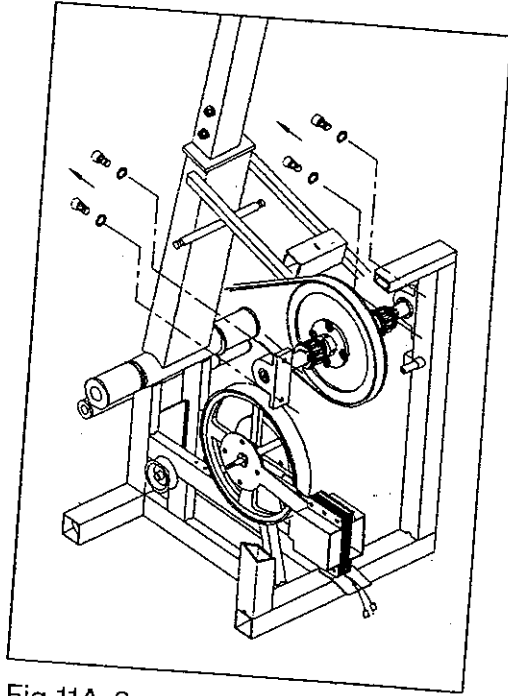

Fig.11A-3

10-3. Remove the gear shaft (see Fig. 11A-4).

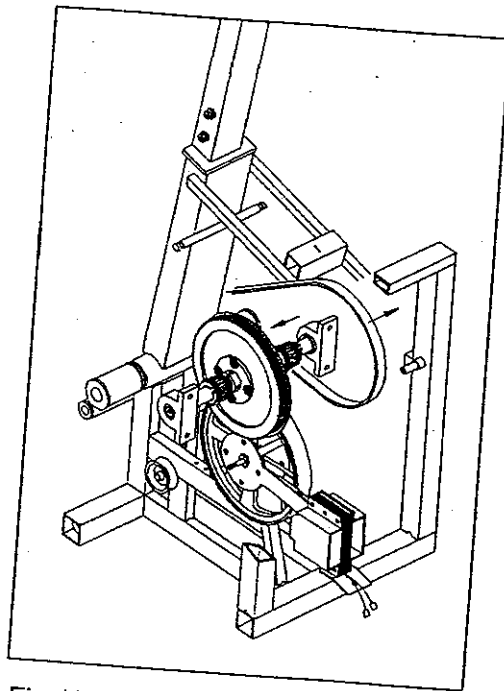

Fig.11A-4

11. Unplug the two blue wires (L1 & L2) located on the drive board from their terminals (see Fig. 12).

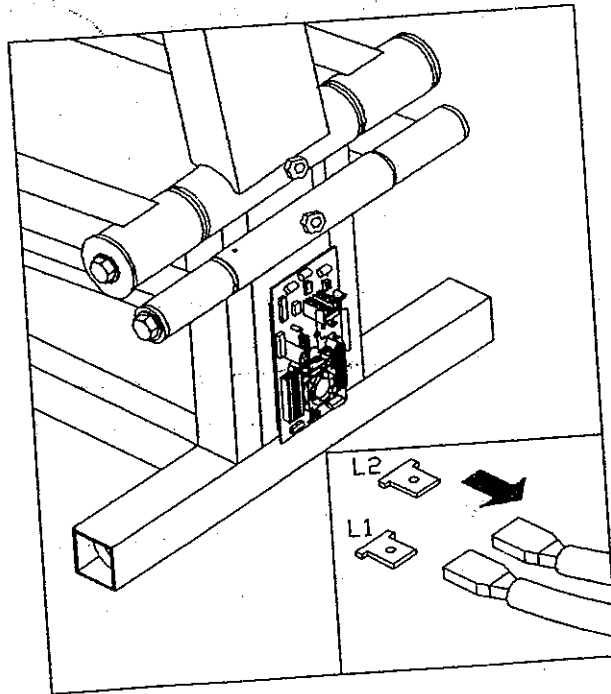

Fig. 12

12. Lift the eddy current system out (see Fig. 13).

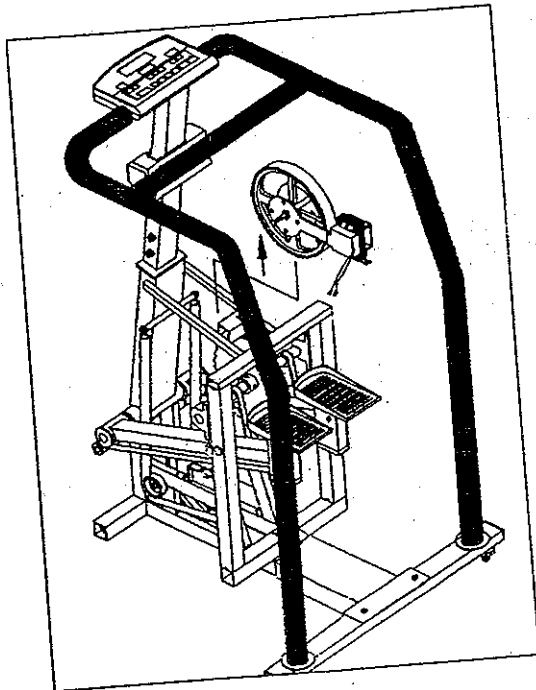

Fig. 13 (7003/7003C)

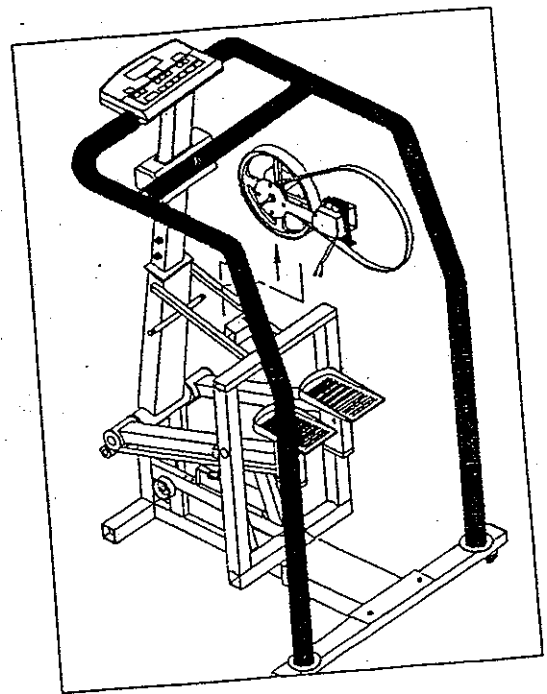

Fig. 13 (7003B/7003N)

To install:

1. Place a new eddy current system into position (see Fig. 14).

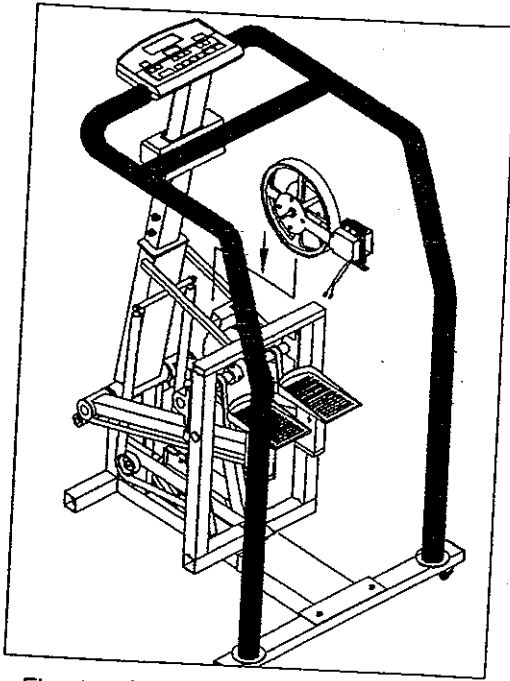

Fig. 14 (7003/7003C)

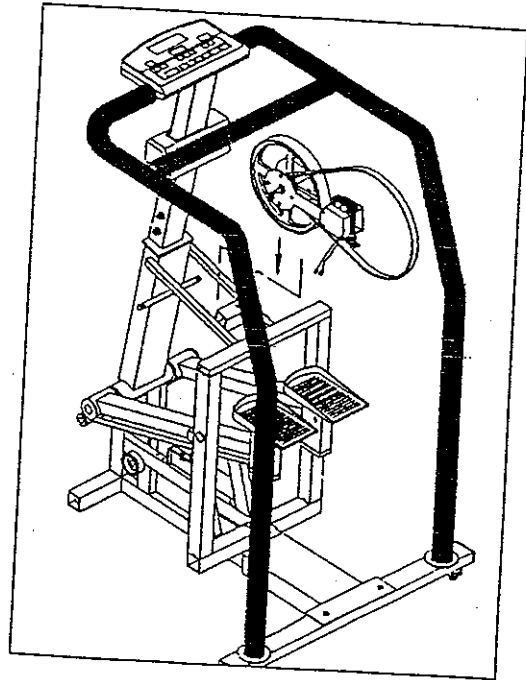

Fig. 14 (7003B/7003N)

2. Plug the two blue wires to the L1 & L2 terminals on the drive board (see Fig. 15).

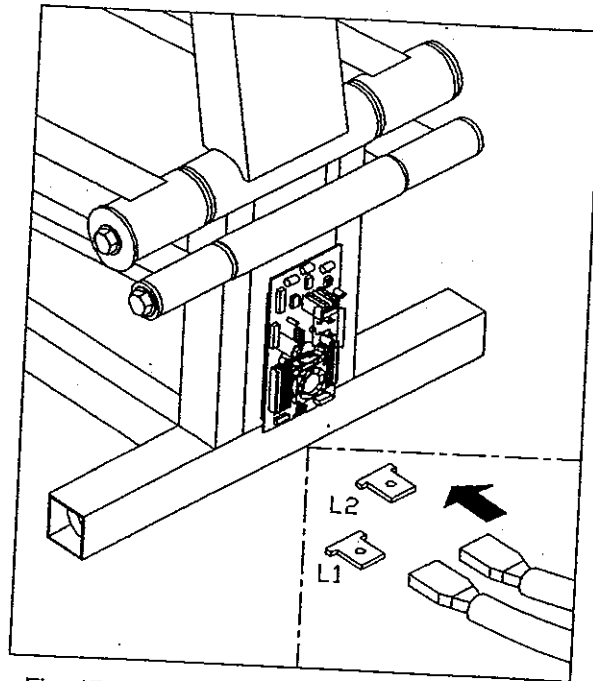

Fig. 15

For 7003 & 7003C

3. Assemble the chain and wheel to the eddy current system's gear, making sure the chain matches up completely with the teeth of the chain wheel and the gear teeth (see Fig. 16-1 to 16-3).

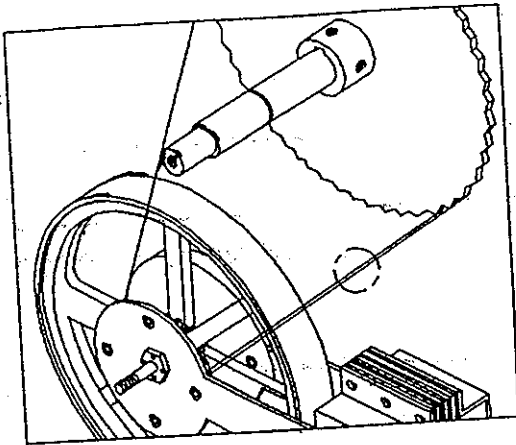

Fig 16-1.

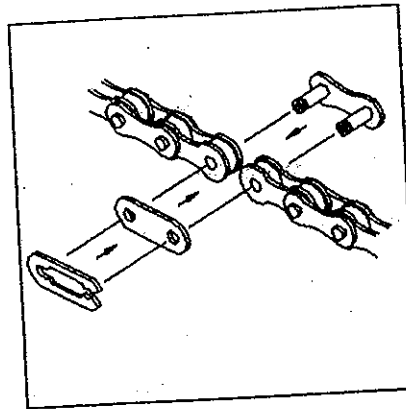

Fig 16-2.

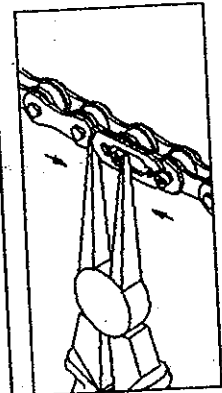

Fig 16-3.

For 7003B & 7003N

3. Assemble the flywheel's poly-V belt over the gear shaft (see Fig. 16A-1).
- 3-1. Assemble both sides of the bearings (pillow block) back into position (see Fig. 16A-2).

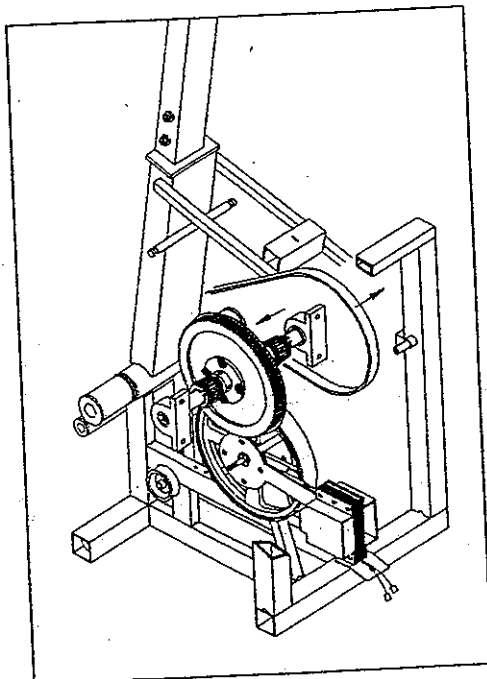

Fig.16A-1

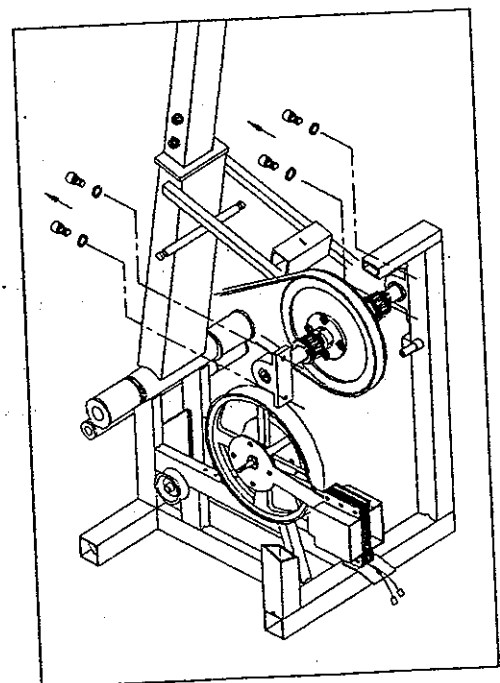

Fig.16A-2

- 3-2. Slide the flywheel's poly-V belt over the idler pulley as step 'A'.
Replace the belt to the gear shaft wheel, making sure the teeth of belt are in the wheel grooves as step "B" (see Fig. 16A-3).

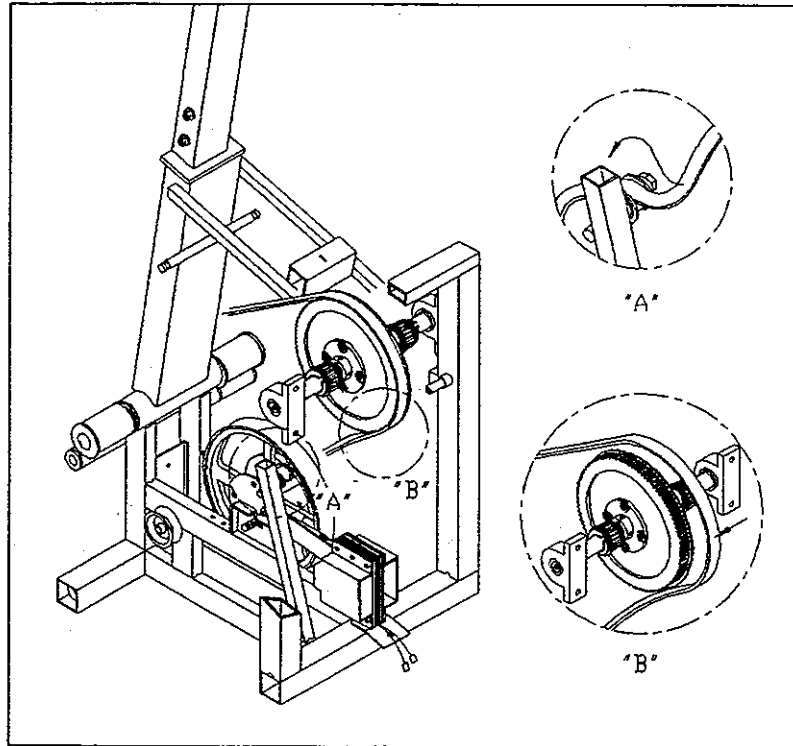

Fig.16A-3

- 3-3. Raise both foot pads to their highest positions. Match the teeth of the poly-V belt into the gear shaft wheel grooves completely (see Fig. 16A-4).

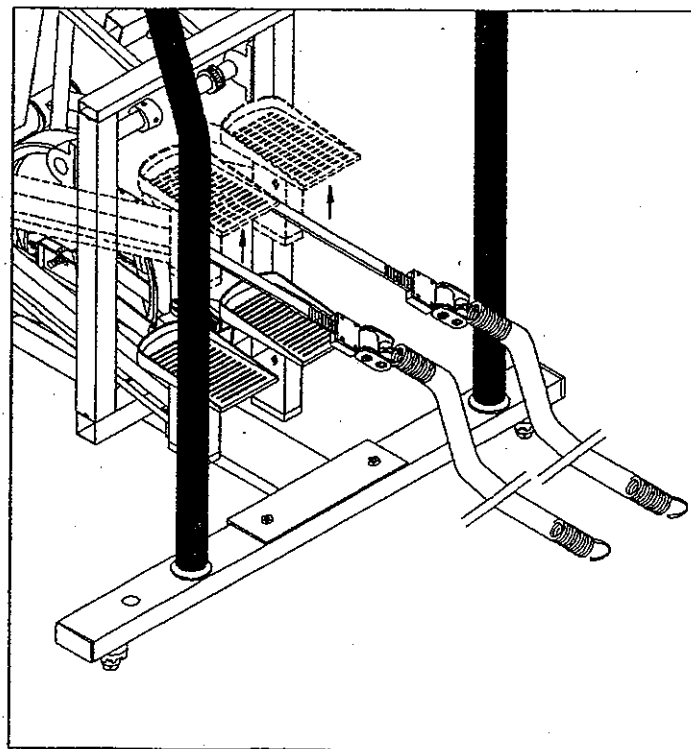

Fig.16A-4

3-4 Raise up the left spring and release it; follow steps A and B (see Fig. 16A-5).

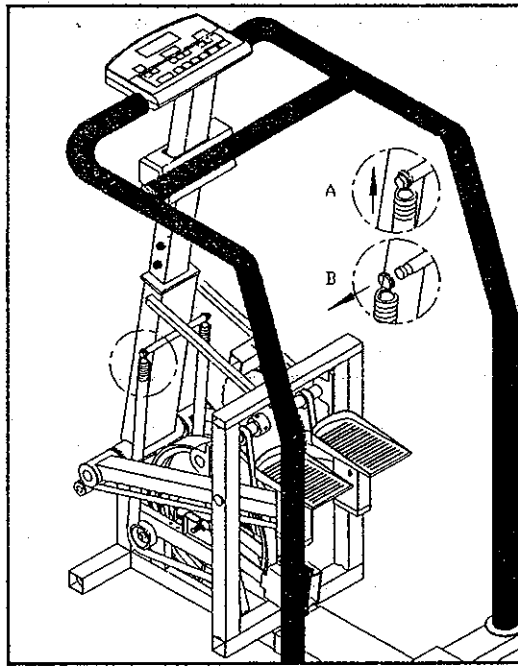

Fig.16A-5

4. Secure the right fitted washer, making sure the washer protrudes into the shaft channel, then tighten the nut clockwise.

Secure the left fitted washer, making sure the washer protrudes into the shaft channel, then tighten the nut clockwise (see Fig. 17 ~ Fig 17-2).

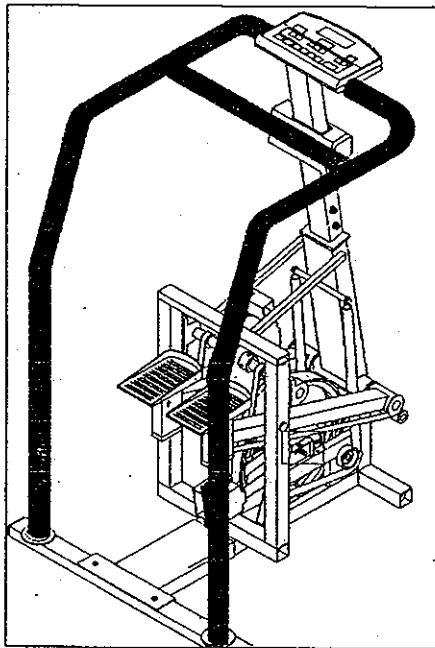

Fig. 17

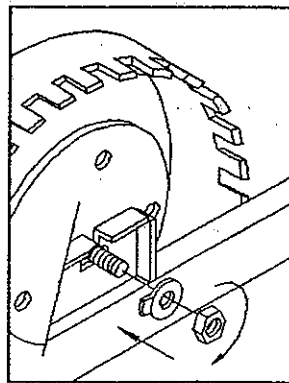

Fig 17-1.

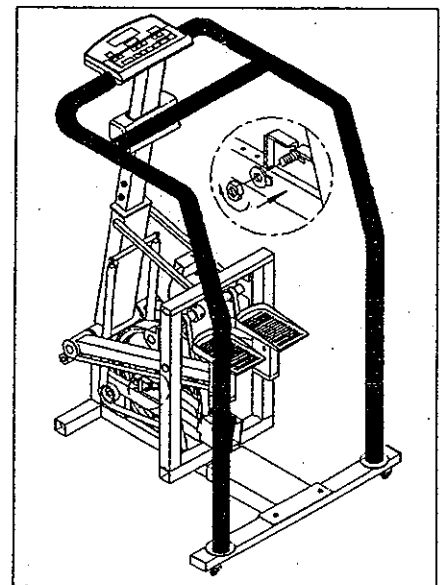

Fig 17-2.

5. Replace the optical switch with two screws. Making sure the space between the optical switch and tachometer wheel is $0.04'' - 0.08''$ (1 mm - 2 mm), then tighten the two screws (see Fig. 18).

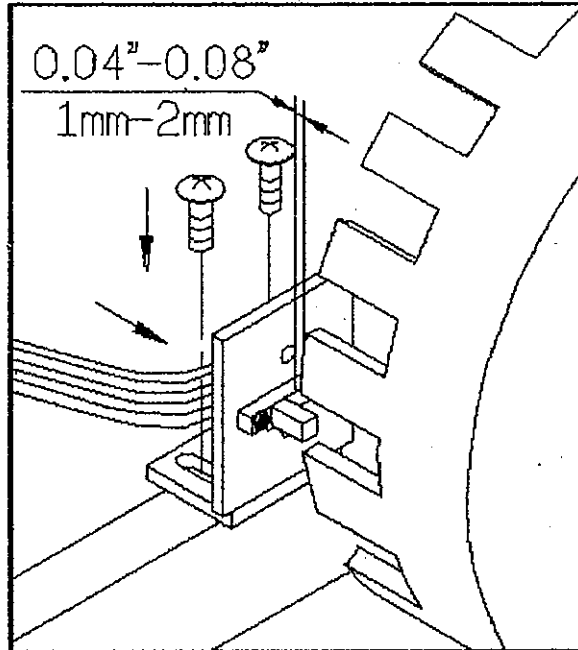

Fig. 18

6. Place the electromagnet unit into position, tighten with flat washer and nut (see Fig. 19).

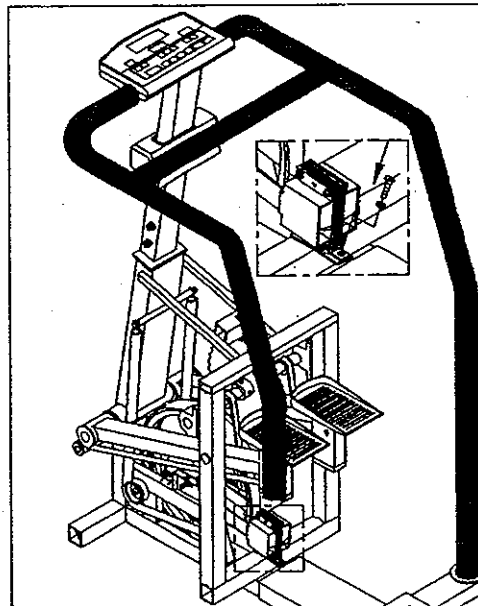

Fig. 19

For 7003B & 7003N

- 6-1. Make sure the gear shaft wheel with idler pulley aligned. And the correct gap between the idler pulley and flywheel should be 5-6 mm (see Fig. 19-1).
- 6-2. If the gap need to be adjusted, use a hex Allen wrench to release both sides of the gear shaft screws, adjust the gear wheel until the correct gap shows, then secure both screws (see Fig. 19-2).

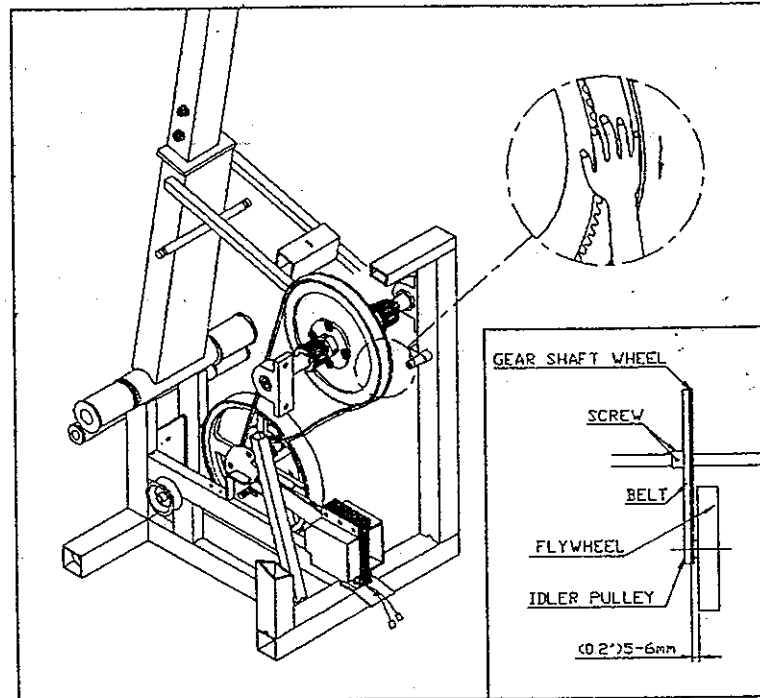

Fig 19-1.

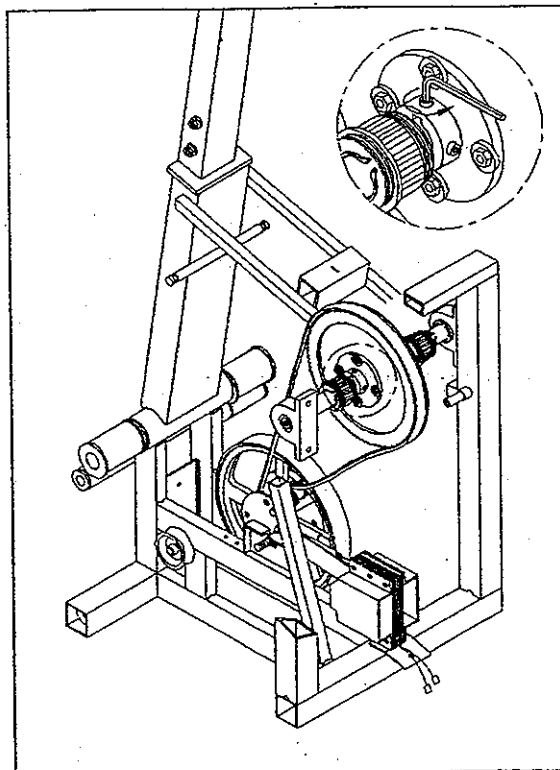

Fig 19-2.

7. Replace the main shroud and tighten with screws (see Fig. 20- 21).

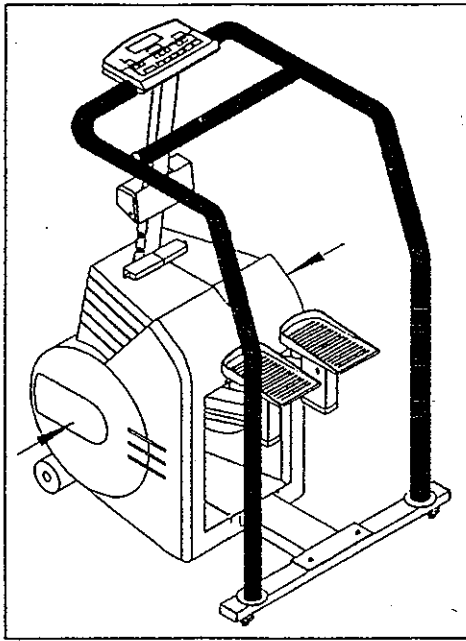

Fig. 20

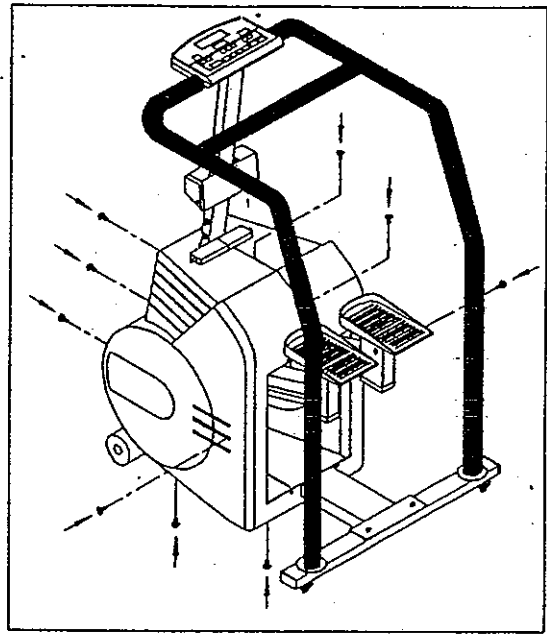

Fig. 21

8. Replace the repair window (see Fig. 22).

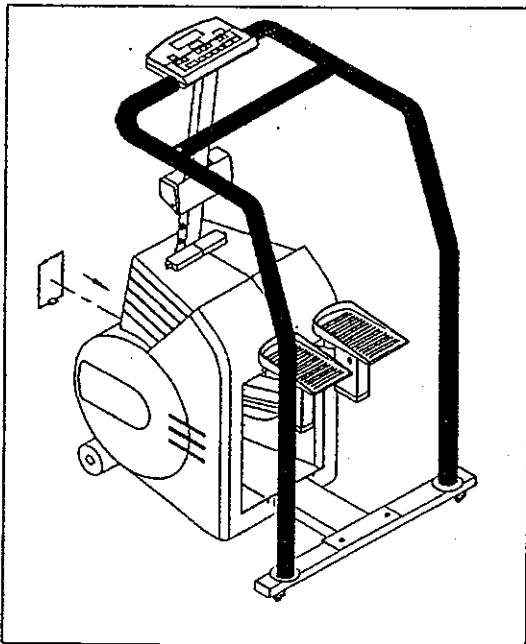

Fig. 22 (7003)

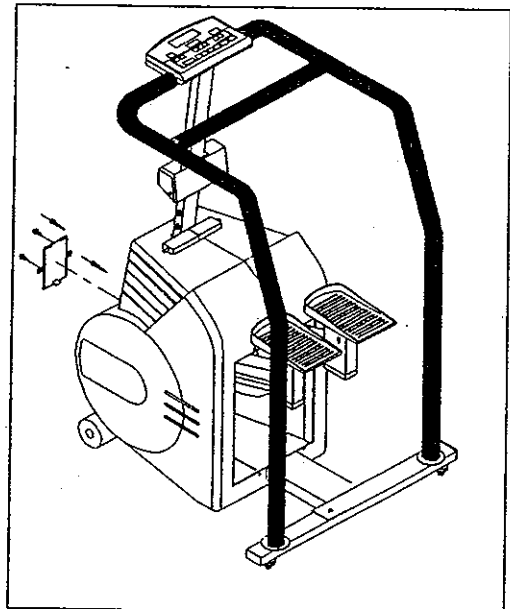

Fig22. (7003/7003B/7003C/7003N)

9. Secure the front cover with screws (see Fig. 23).

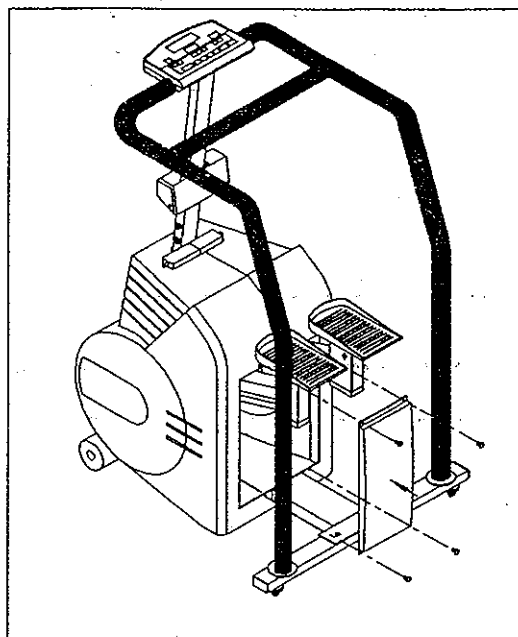

Fig. 23

10. Replace the transport wheels, tighten with washer and screw, then cover with labels (see Fig. 24).

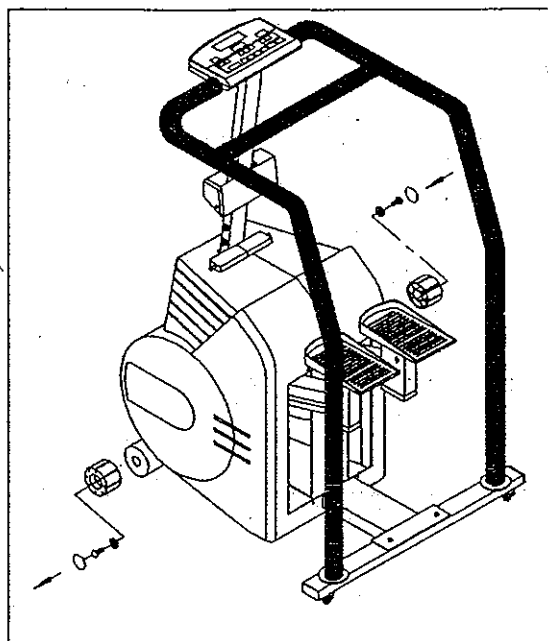

Fig. 24

11. Replace the post shroud, secure with two screws (see Fig. 25 & 26).

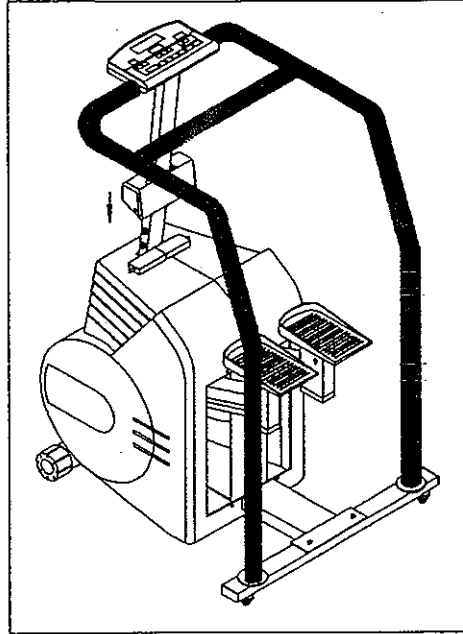

Fig.25

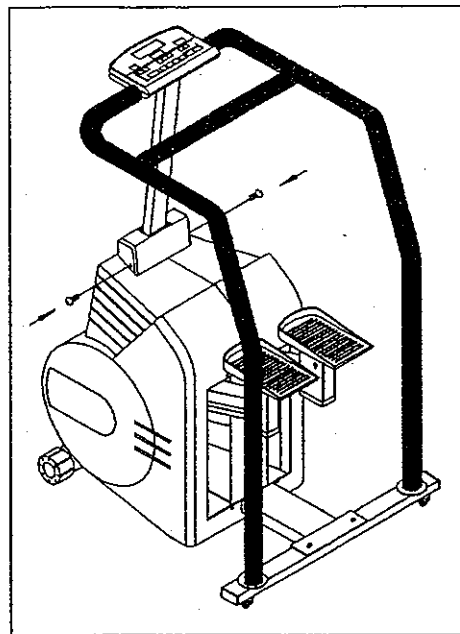

Fig.26

L. OPTICAL SWITCH REMOVAL & INSTALLATION PROCEDURE

1. Remove the two screws securing the post shroud (see Fig. 1 & 2).

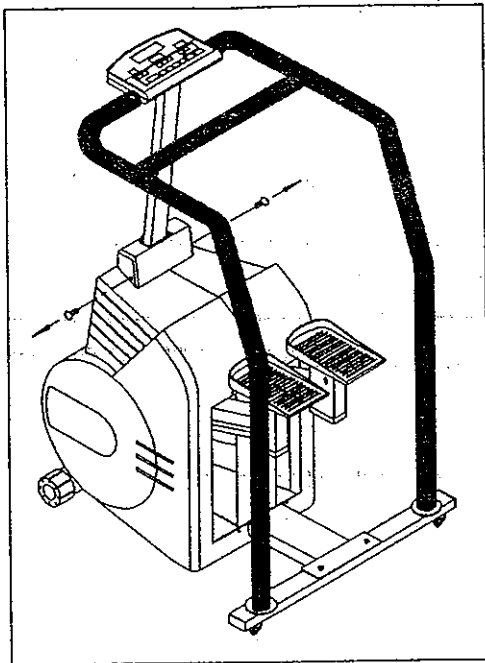

Fig.1

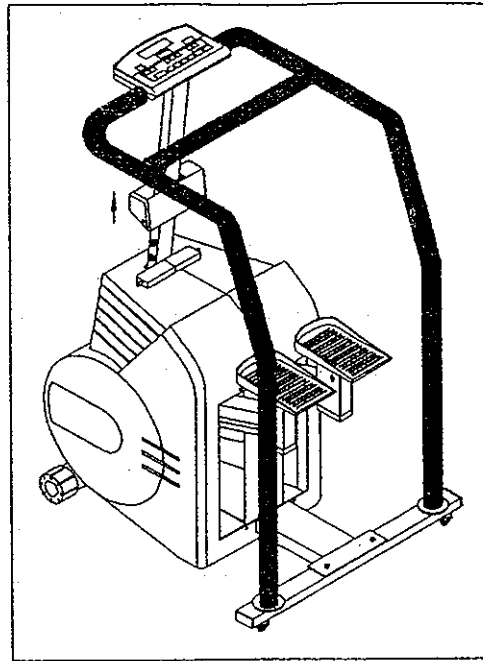

Fig. 2

2. Remove the transport wheel labels first, then unscrew the transport wheels on the front of the stair climber. Remove both wheels (see Fig. 3).

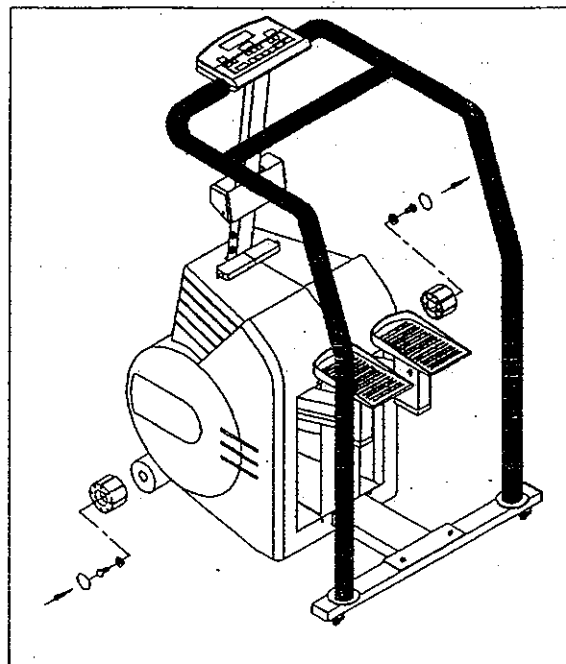

Fig. 3

3. Remove the four screws securing the front cover (see Fig. 4).

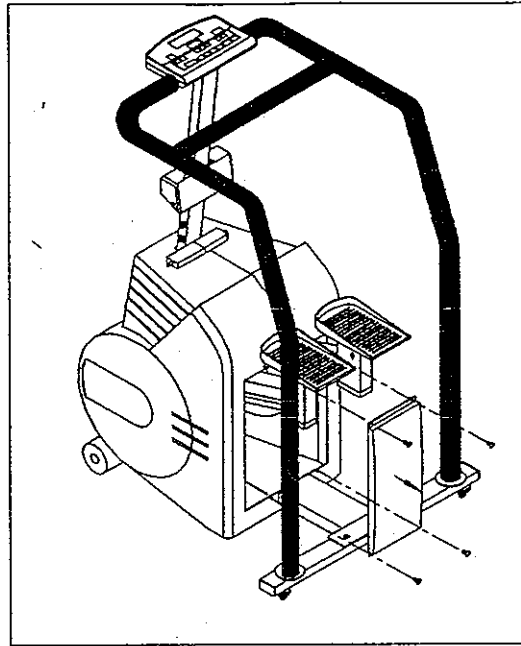

Fig. 4

4. Remove the repair window (see Fig. 5).

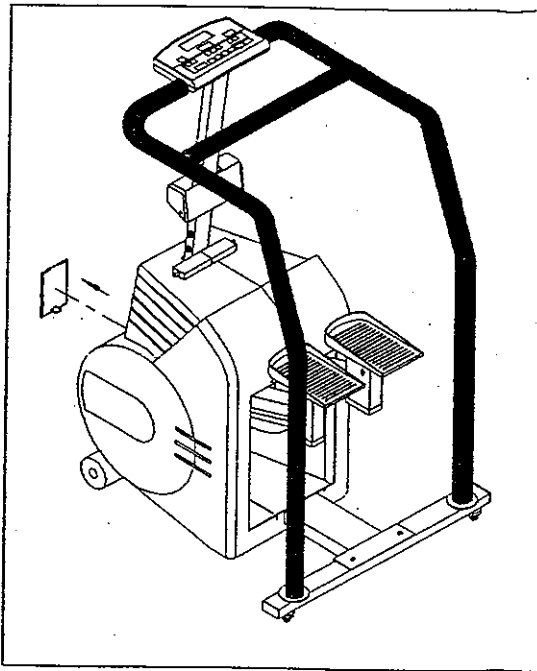

Fig. 5 (7003)

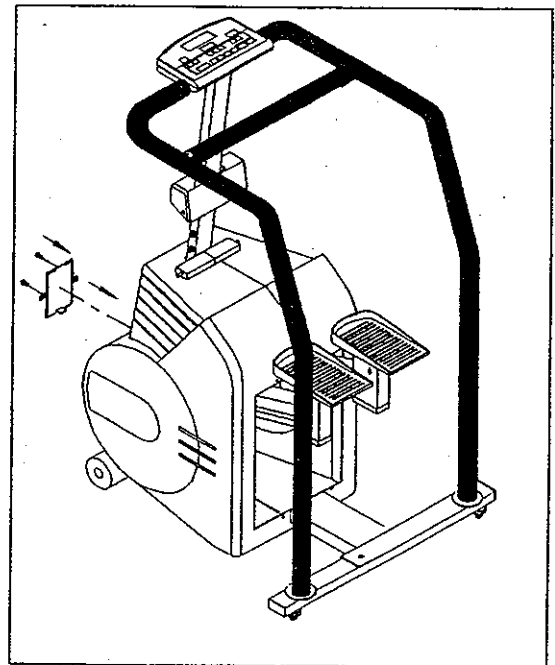

Fig5. (7003/7003B/7003C/7003N)

5. Remove the nine screws securing the main shroud (see Fig. 6).

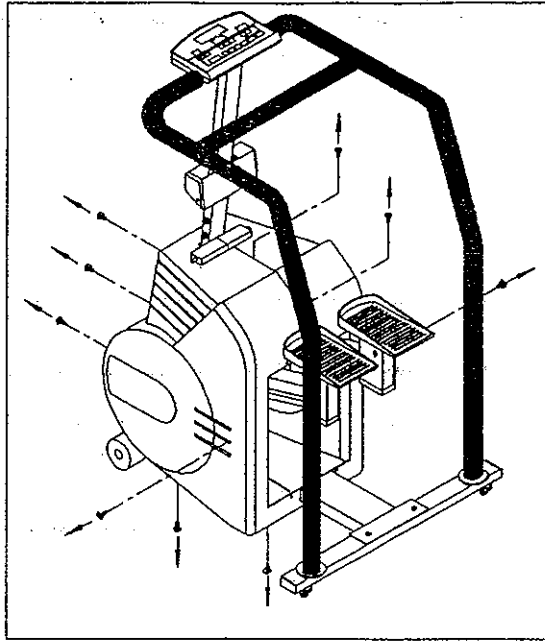

Fig. 6

6. Remove the main shroud (see Fig. 7).

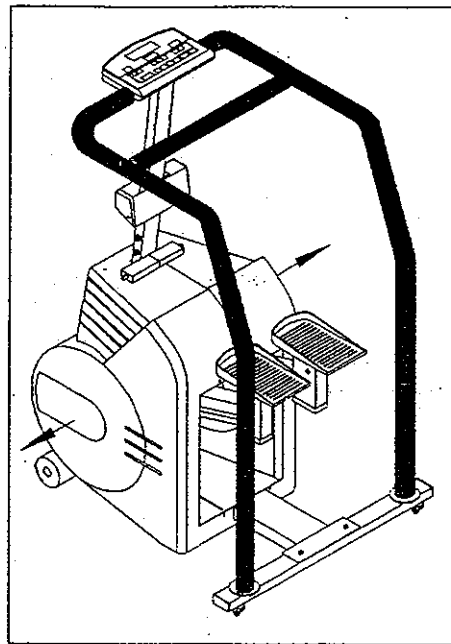

Fig. 7

7. Unplug the 4 pin connector on the drive board (see Fig. 8).

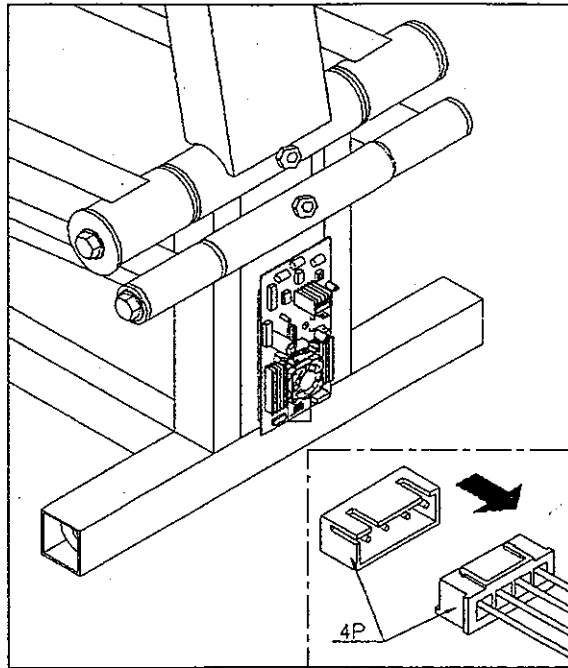

Fig. 8

8. Unscrew the two screws securing the optical switch (see Fig. 9) and remove.

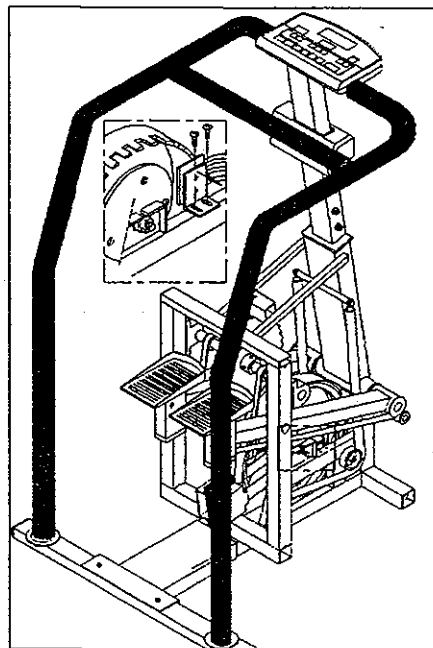

Fig. 9

To install:

1. Install the new optical switch with two screws. Make sure the space between the optical switch and the tachometer wheel is $0.04'' - 0.08''$ ($1\text{ mm} - 2\text{ mm}$), once it is properly aligned, turn the eddy current system's wheel by hand to make sure it turns freely. Then tighten the two screws (see Fig. 10 to 10-2).

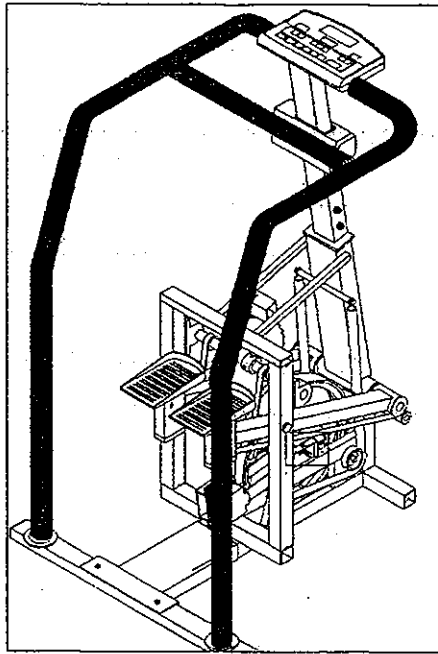

Fig. 10

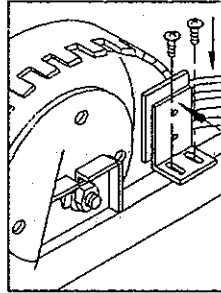

Fig. 10-1

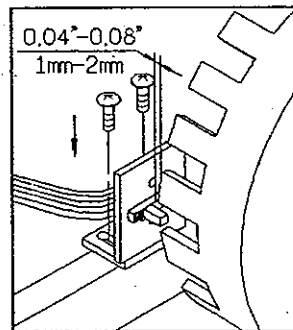

Fig. 10-2

2. Plug the 4 pin connector into its socket on the drive board (see Fig. 11).

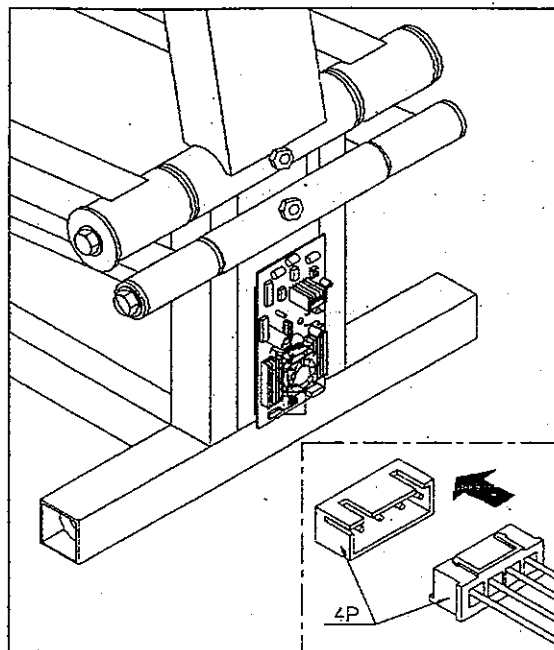

Fig. 11

3. Replace the main shroud and tighten with screws (see Fig. 12 & 13).

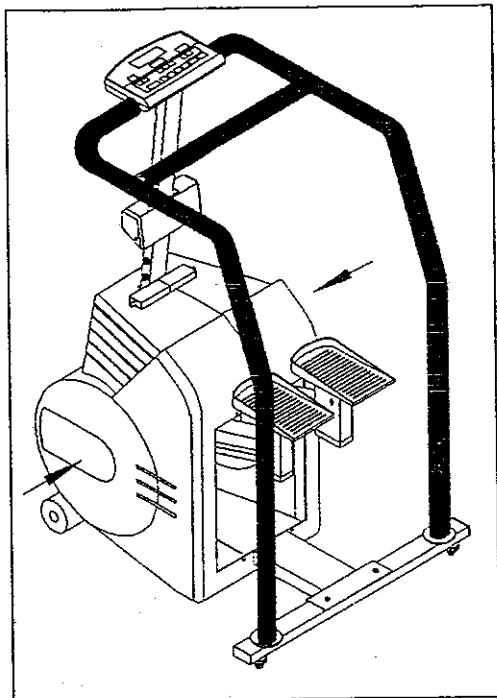

Fig. 12

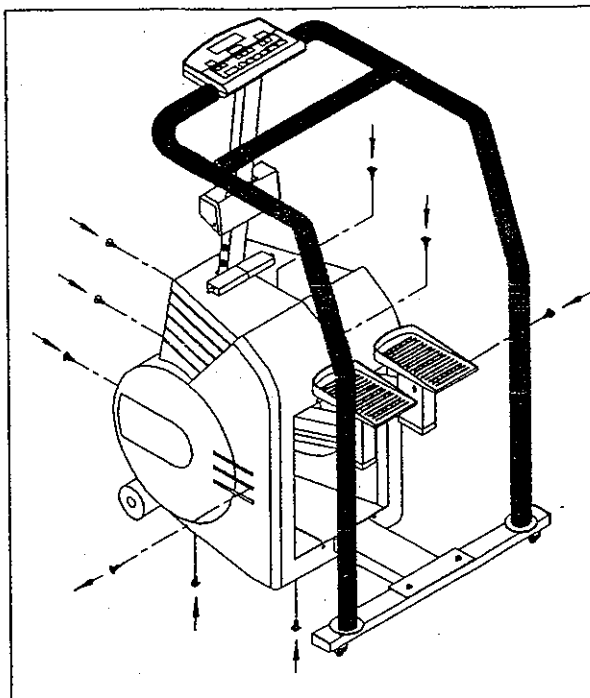

Fig. 13

4. Replace the repair window into position (see Fig. 14).

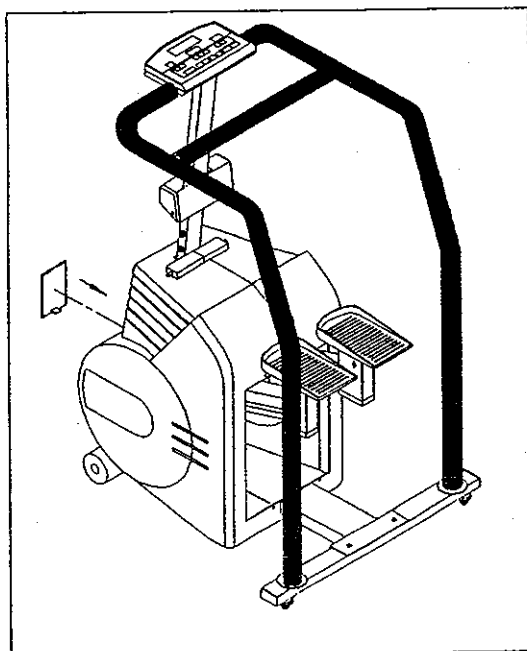

Fig. 14 (7003)

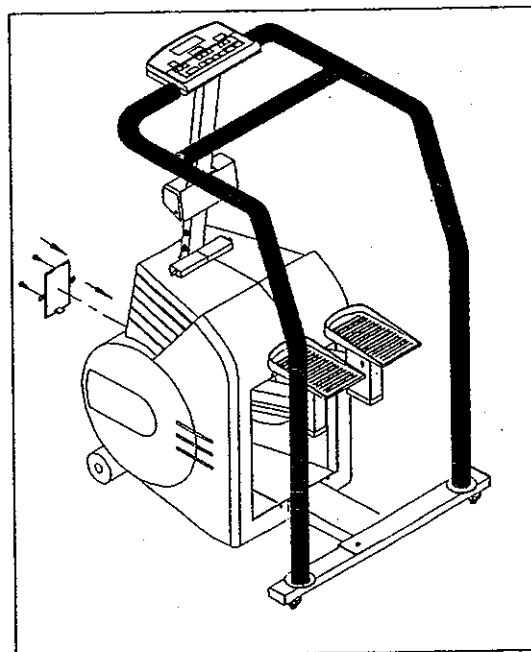

Fig. 14. (7003/7003B/7003C/7003N)

5. Secure the front cover with screws (see Fig. 15).

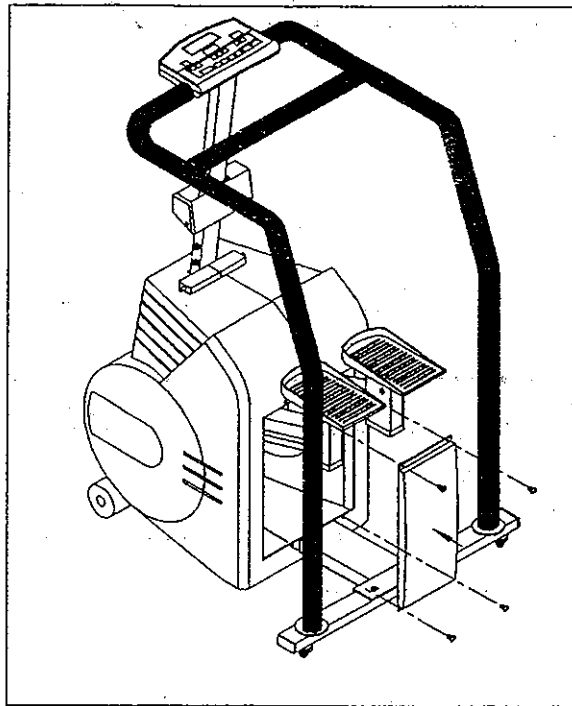

Fig. 15

6. Replace the transport wheels, tighten with screw and washer, then cover with labels (see Fig. 16).

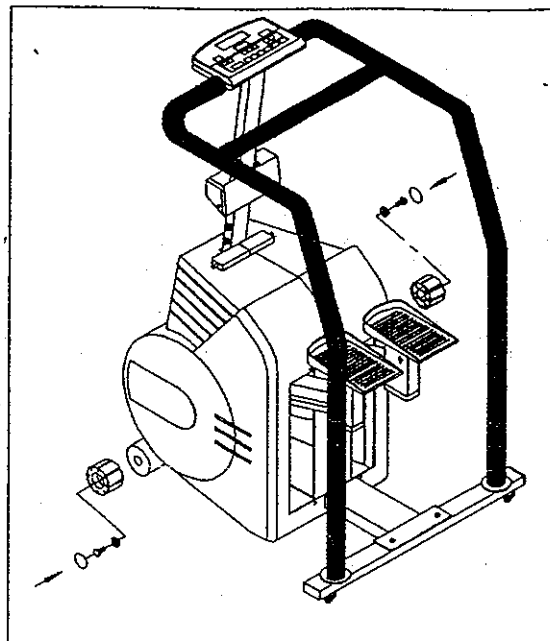

Fig. 16

7. Replace the post shroud, secure with two screws (see Fig. 17 & 18).

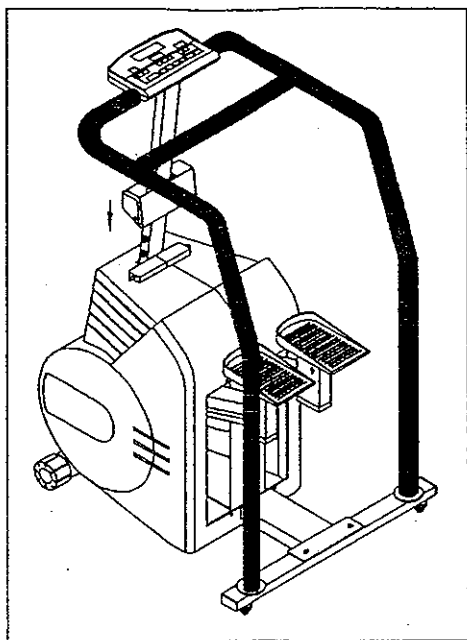

Fig. 17

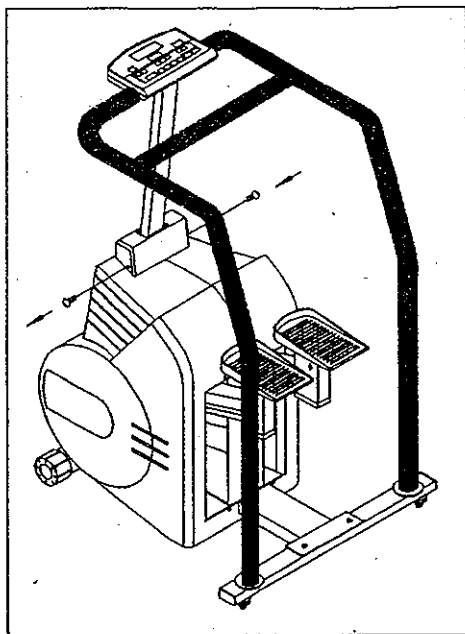

Fig. 18

M. TERMINAL REMOVAL AND INSTALLATION

1. Remove all the screws securing the handlebars and rear base (see Fig. 1).

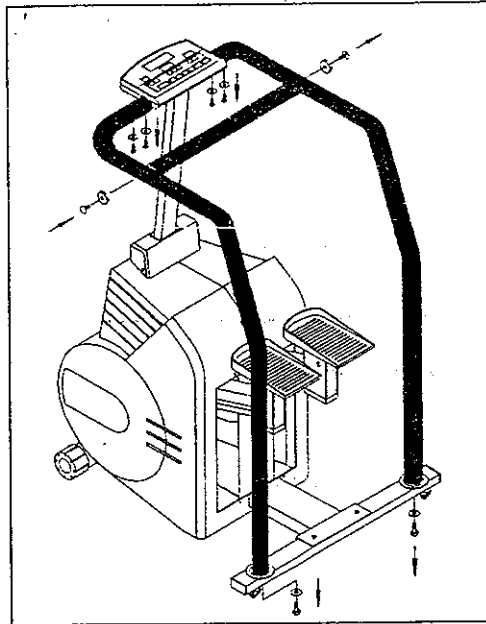

Fig.1

2. Unscrew the two screws securing the post shroud (see Fig. 2).

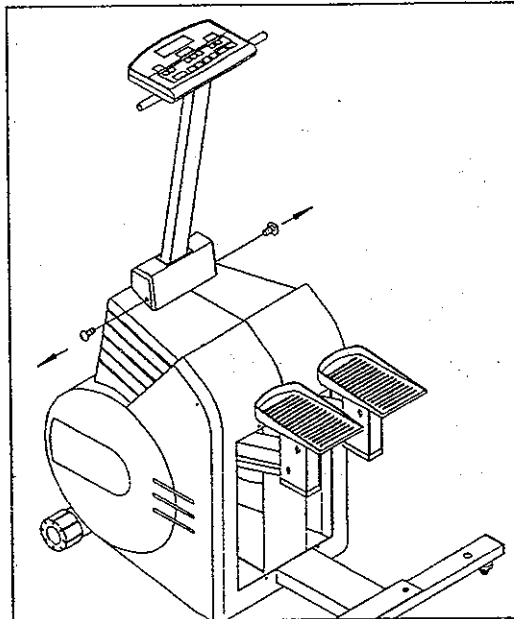

Fig. 2

3. Push the post shroud up and then unscrew all the screws and washers securing the front post (see Fig. 3).

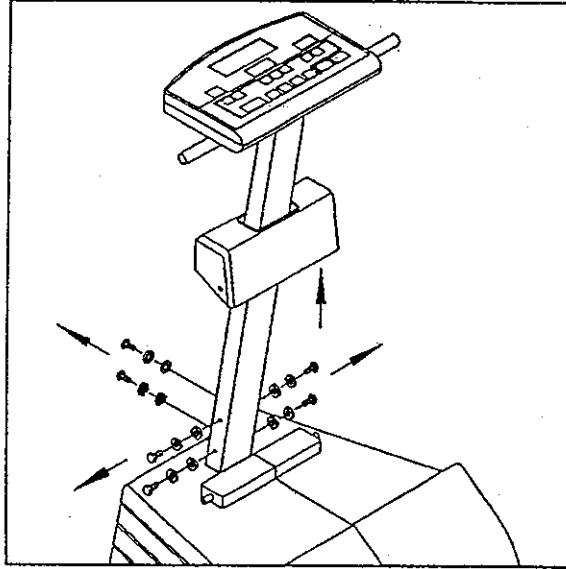

Fig. 3

4. Remove the front post, first pull back the retaining clips, then release the cable from its upper socket on the terminal.

Pull back the retaining clips on the terminal's lower socket to release the cable.

NOTE: Do not let the cable slip into the inside of the shroud.

Then, remove the two screws and bushings securing the terminal (see Fig. 4) and remove.

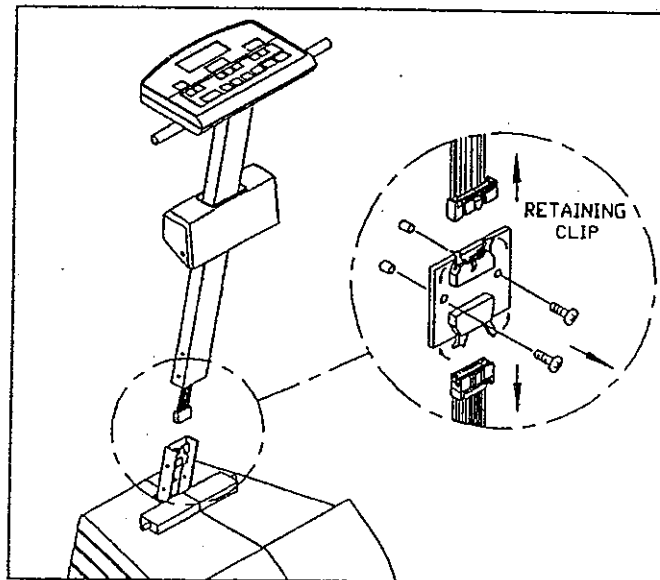

Fig. 4

To install:

1. Install the new terminal and secure with two bushings and screws. Then plug two 16 pin cables into their sockets on the terminal (see Fig. 5).

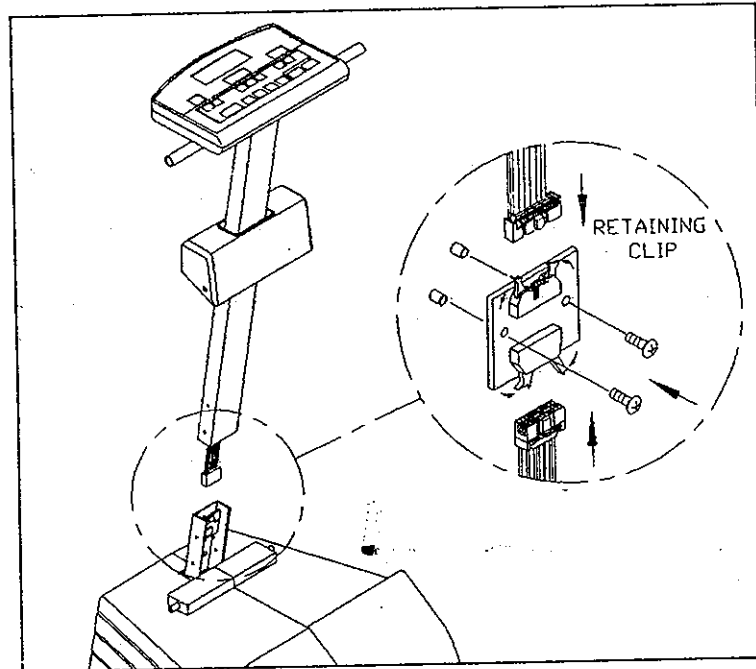

Fig. 5

2. Assemble the front post and tighten all the screws and washers. Then replace the post shroud (see Fig. 6).

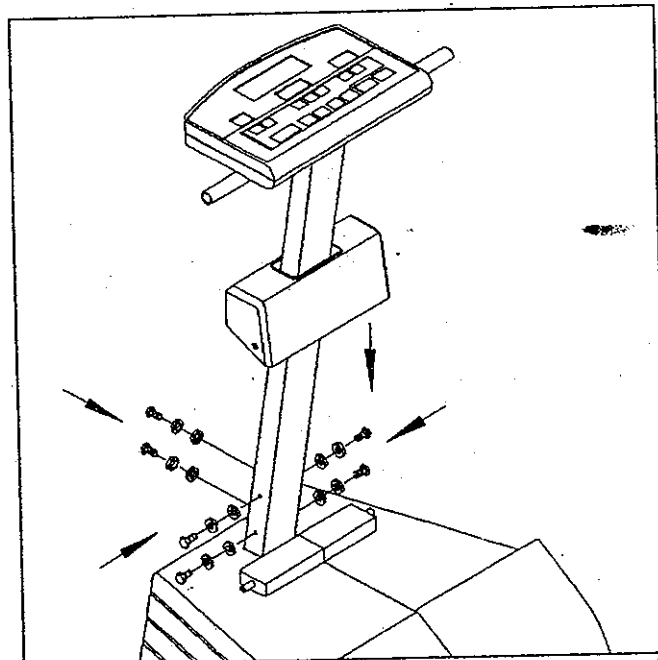

Fig. 6

3. Secure the post shroud with two screws (see Fig. 7).

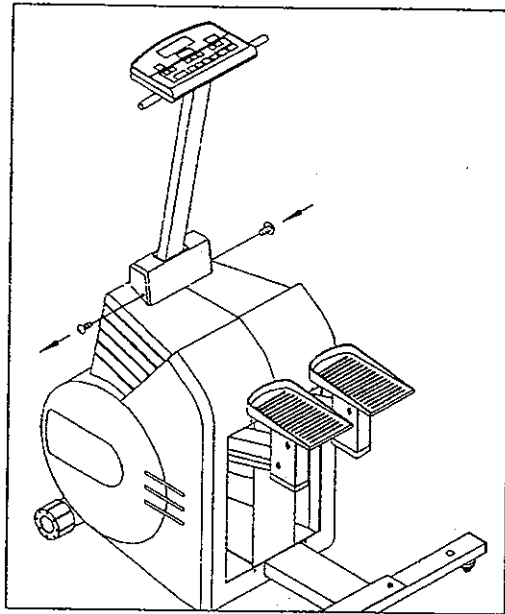

Fig. 7

4. Insert the bottom handrails into the rear base and the upper rails to the electronics package. **DO NOT TIGHTEN YET.**

Assemble the cross handlebar to the front of the handrail and secure with screws and washers.

Now, tighten all the screws (see Fig. 8).

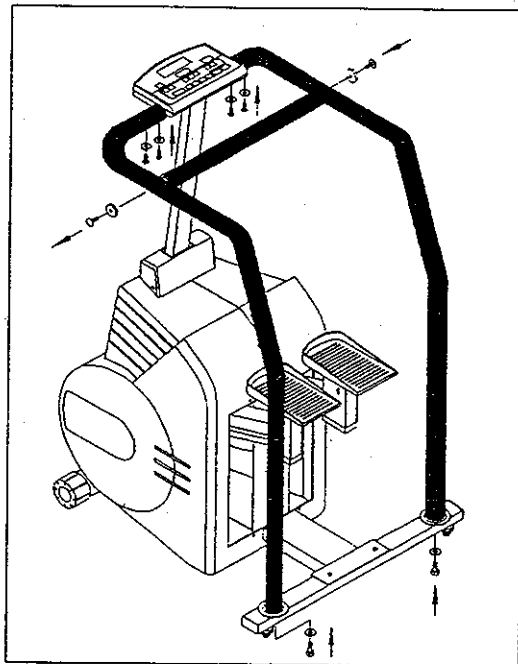

Fig. 8

N. CHAIN REMOVAL AND INSTALLATION PROCEDURE (FOR 7003 & 7003C)

1. Remove the two screws securing the post shroud (see Fig. 1 & 2).

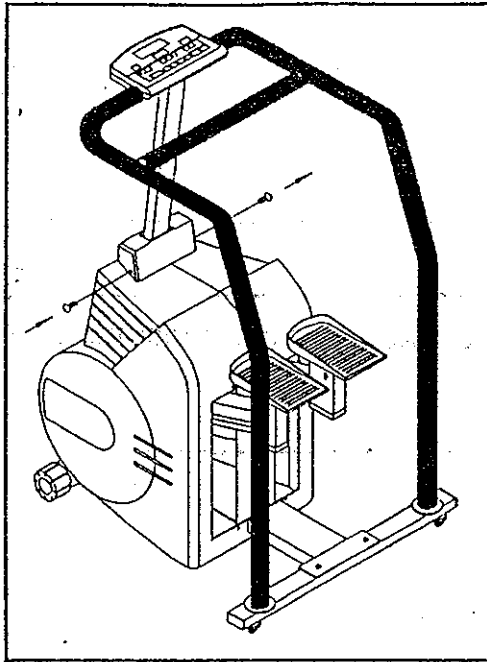

Fig.1

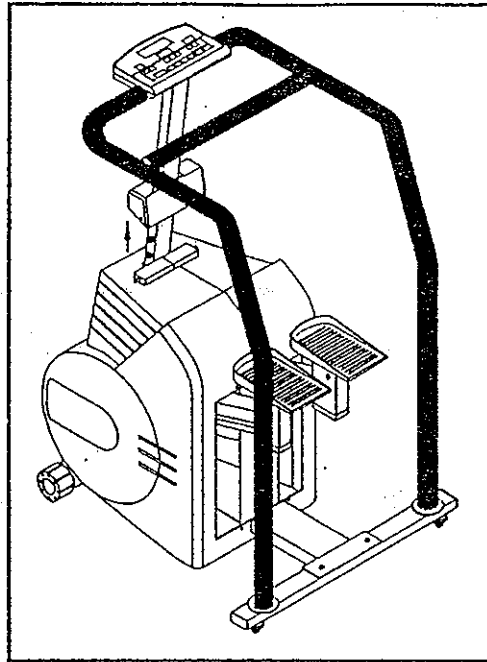

Fig. 2

2. Remove the transport wheel labels first, then unscrew the transport wheels on the front of the stair climber. Remove both wheels (see Fig. 3).

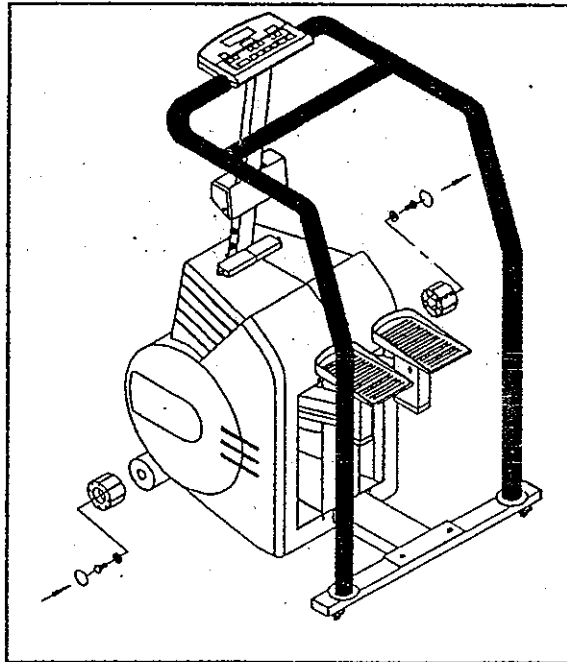

Fig. 3

3. Remove the four screws securing the front cover (see Fig. 4).

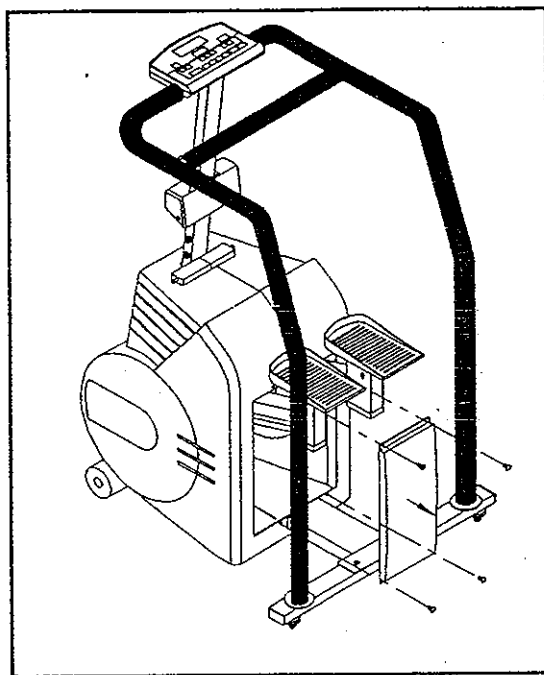

Fig. 4

4. Remove the repair window (see Fig. 5).

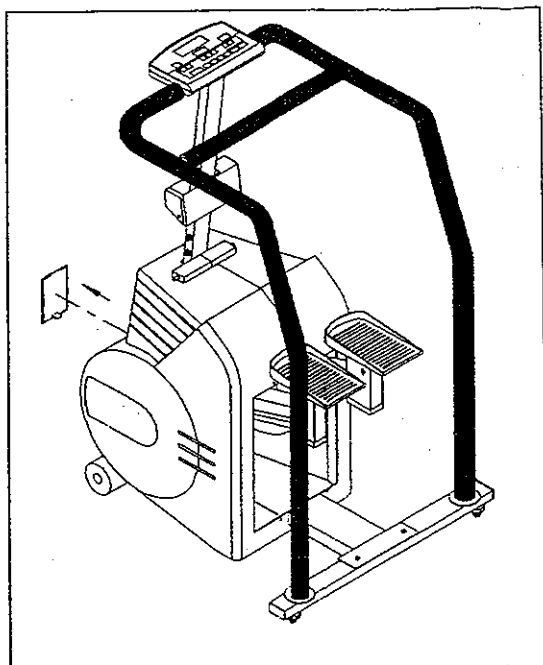

Fig. 5 (7003)

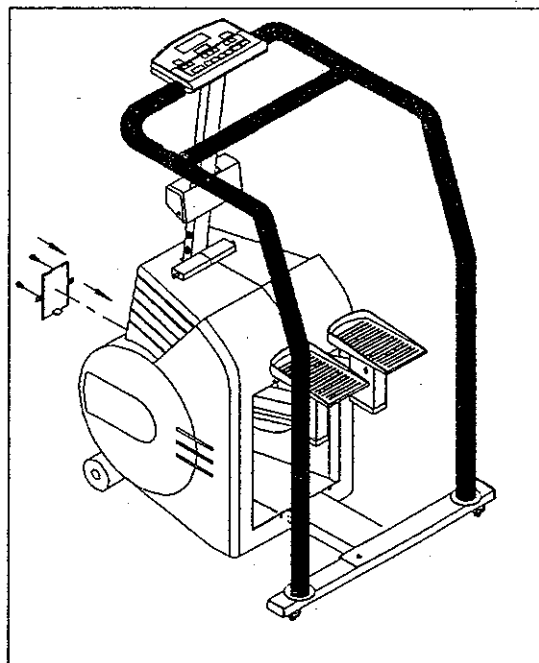

Fig5. (7003/7003B/7003C/7003N)

5. Remove the nine screws securing the main shroud. (see Fig. 6).

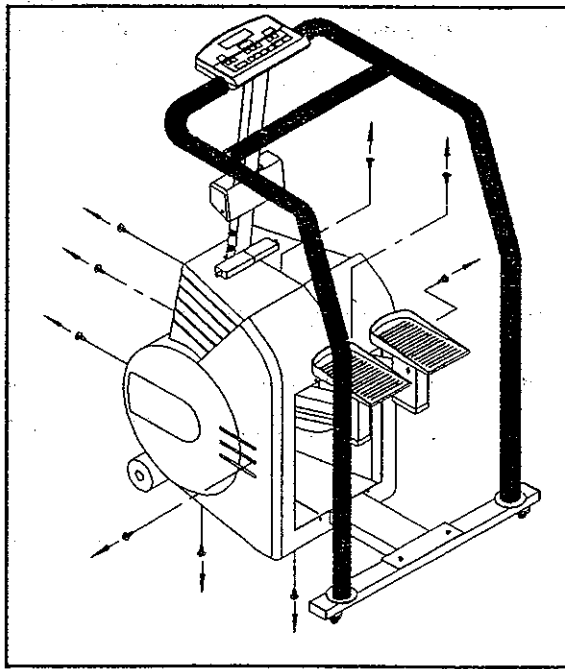

Fig. 6

6. Remove the main shroud (see Fig. 7).

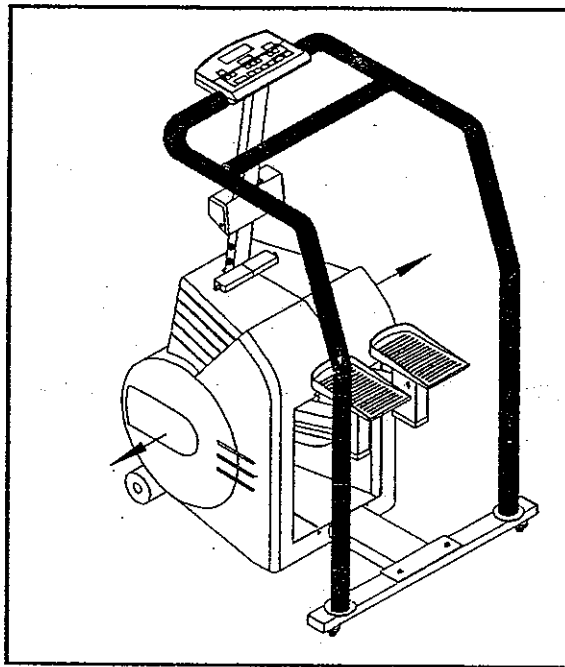

Fig. 7

7. Raise up the left spring and release it; follow steps A and B (see Fig. 8).

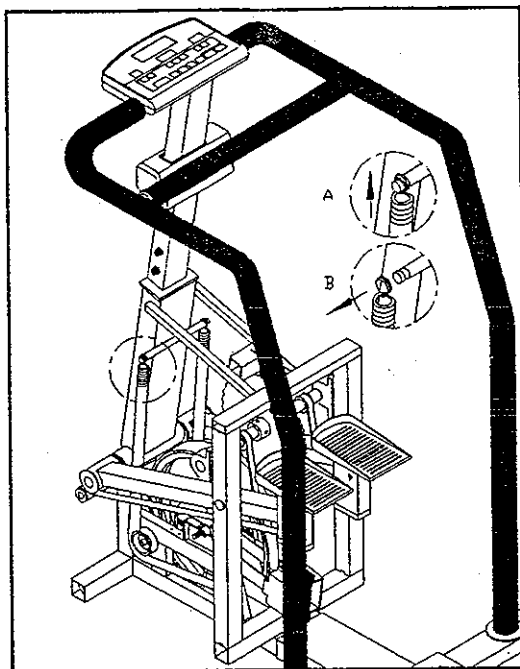

Fig. 8

8. Place the left foot pad at its lowest position, then slide out the left spring (see Fig. 9).

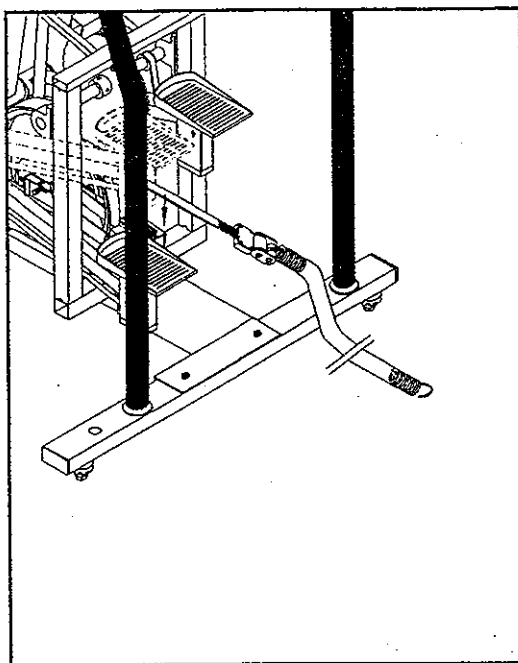

Fig. 9

9. Find the chain connector, then use a clip to remove it. Then remove the disconnected chain (see Fig. 10-12).

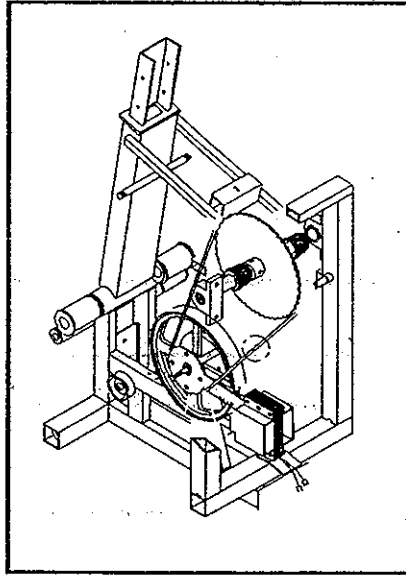

Fig. 10

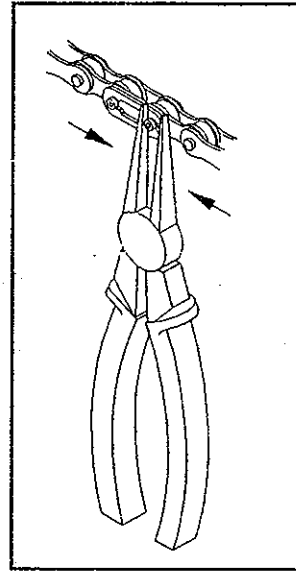

Fig. 11

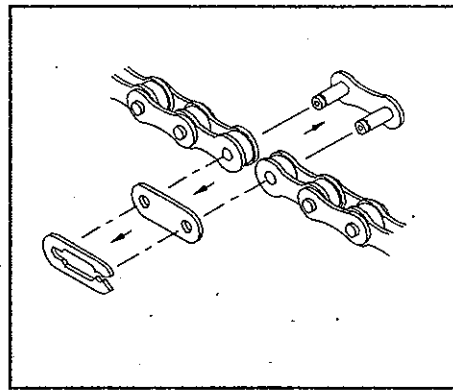

Fig. 12

To install:

1. Attach a new chain to the chain wheel through the gear (see Fig. 13).

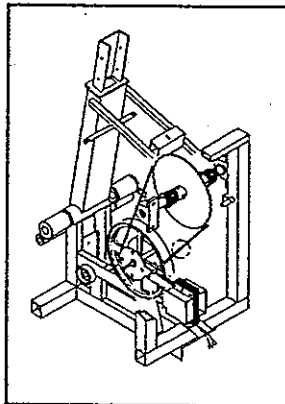

Fig. 13

2. Connect the chain with connector, washer, and holder (see Fig. 14).

Use a clip to secure the chain (see Fig. 15).

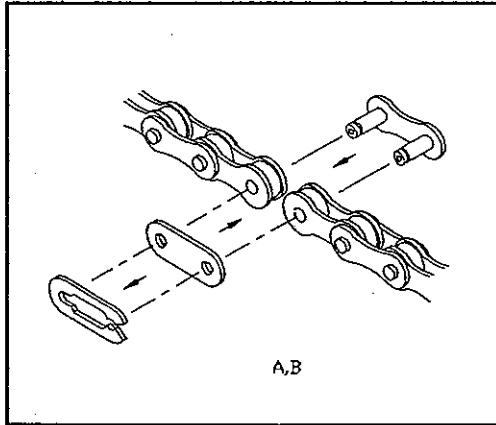

Fig. 14

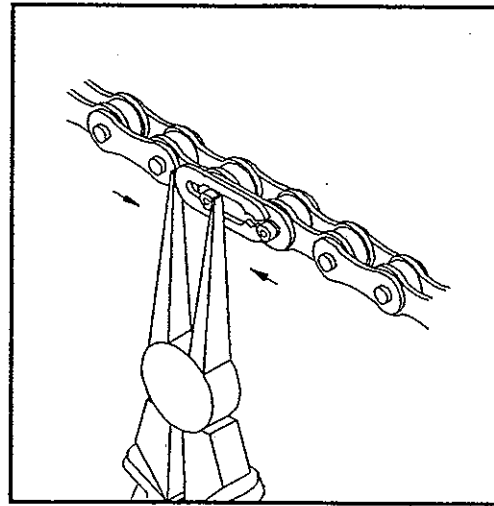

Fig. 15

3. Raise the left foot pad to its highest point. Match the teeth of the poly-V belt into the gear teeth (see Fig. 16 & 17)

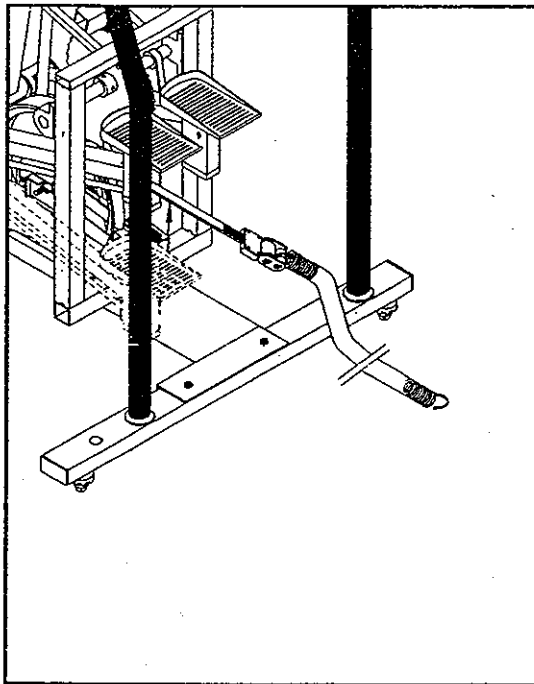

Fig. 16

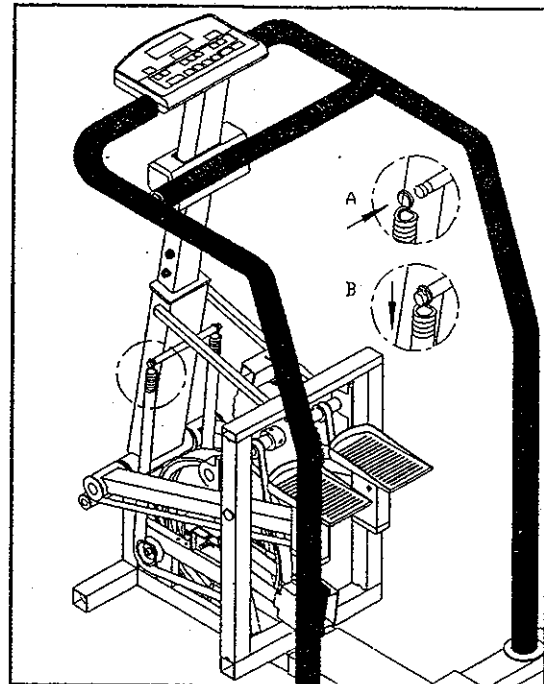

Fig. 17

4. Secure the left spring in its correct position (see Fig. 17).

5. Replace the main shroud and tighten with screws (see Fig. 18 & 19).

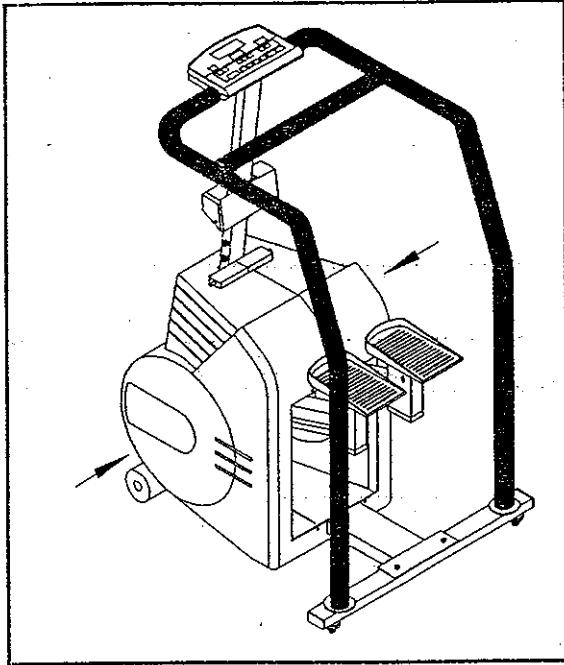

Fig. 18

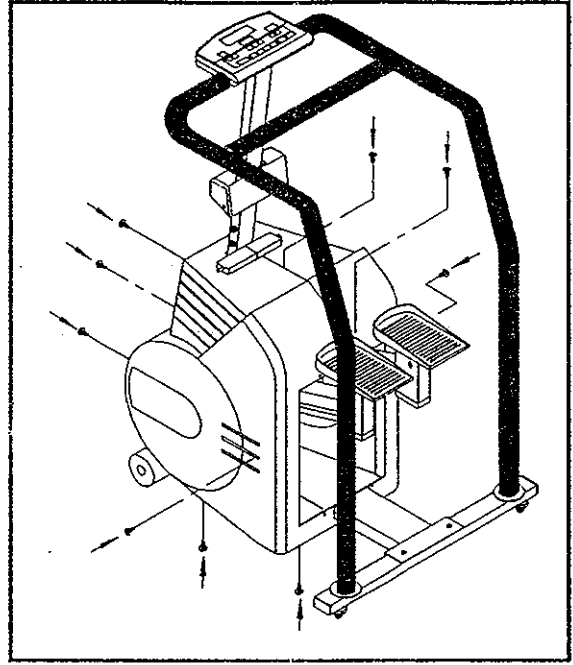

Fig. 19

6. Replace the repair window (see Fig. 20).

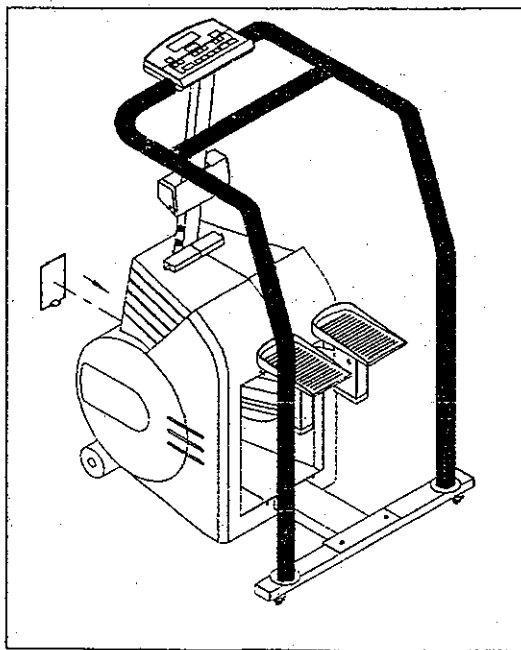

Fig. 20 (7003)

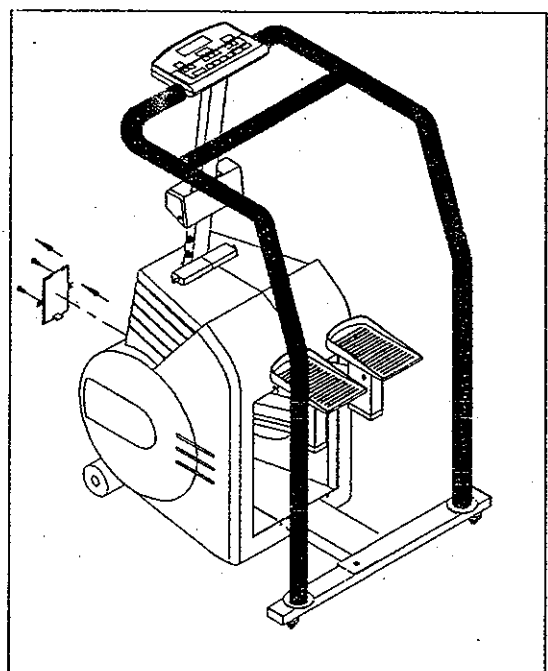

Fig. 20. (7003/7003B/7003C/7003N)

7. Secure the front cover with screws (see Fig. 21).

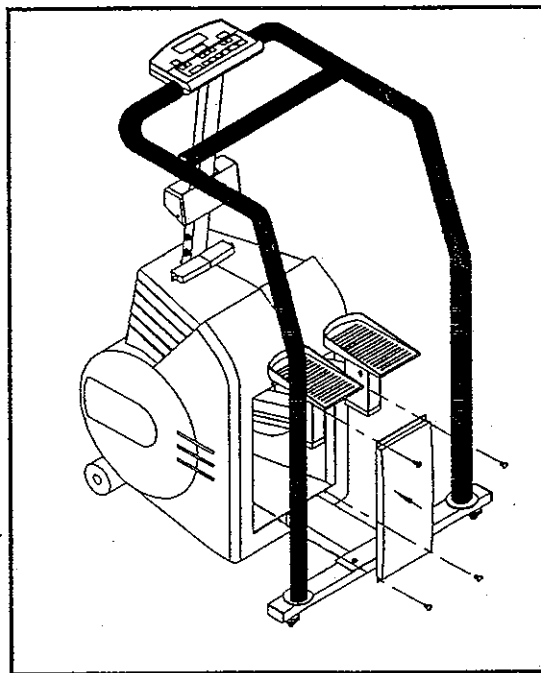

Fig. 21

8. Replace both transport wheels, tighten with screw and washer, then cover with labels (see Fig. 22).

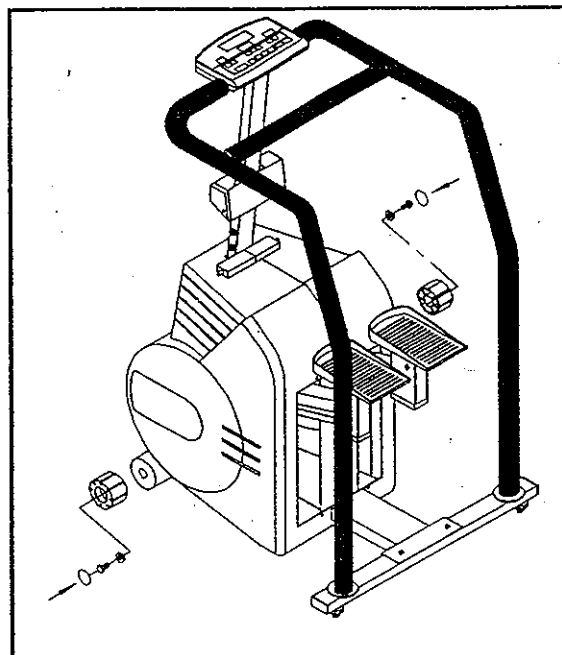

Fig. 22

9. Replace the post shroud, secure with two screws (see Fig. 23. & 24).

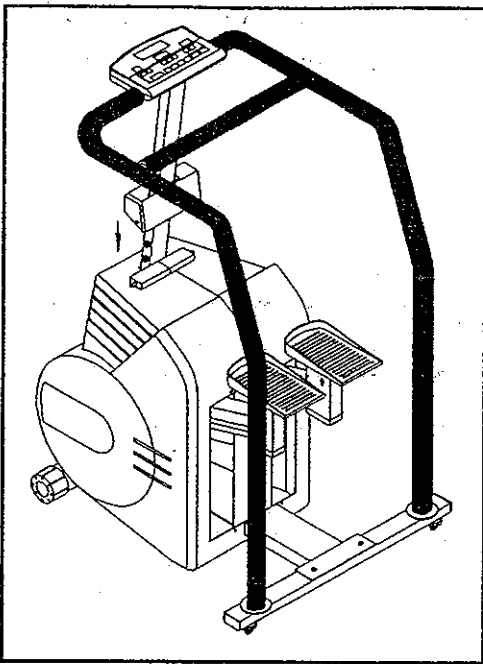

Fig. 23

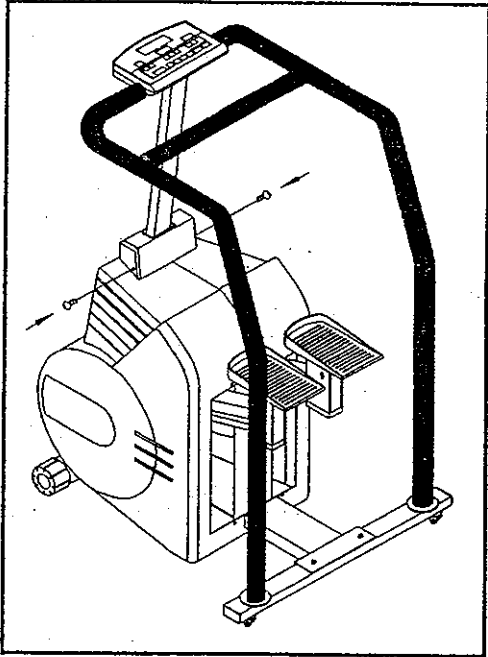

Fig. 24

O. CHAIN/BELT WHEEL AND GEAR SHAFT REMOVAL AND INSTALLATION PROCEDURE

1. Remove the two screws securing the post shroud (see Fig. 1 & 2).

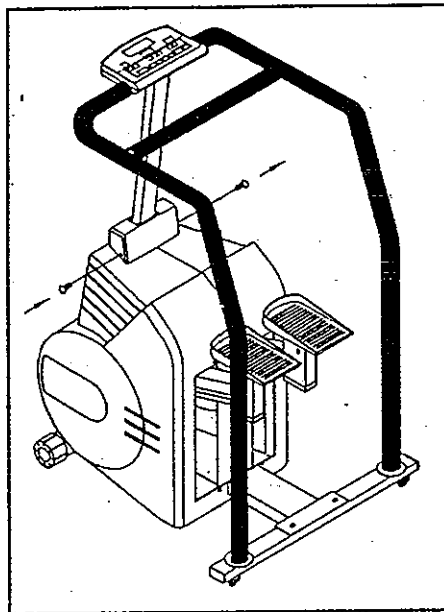

Fig.1

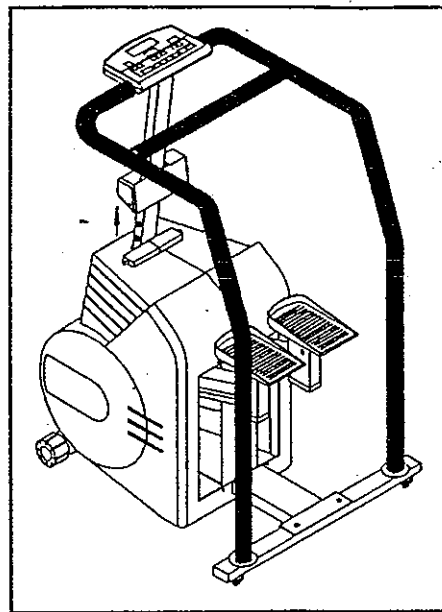

Fig. 2

2. Remove the transport wheel labels first, then unscrew the transport wheels on the front of the stair climber. Remove both wheels (see Fig. 3).

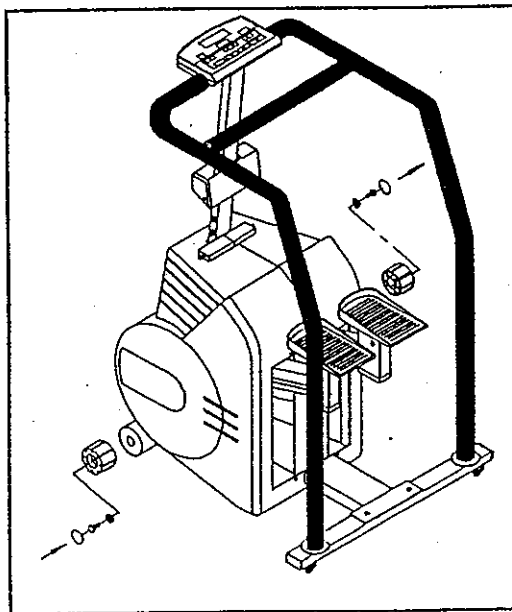

Fig. 3

3. Remove the four screws securing the front cover (see Fig. 4).

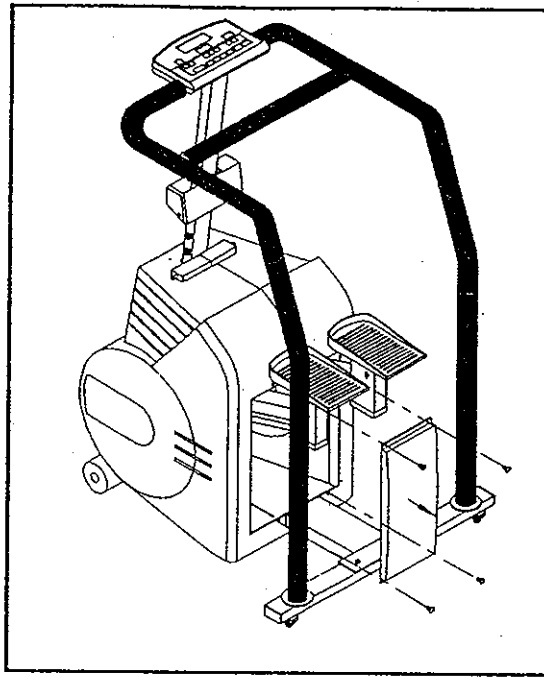

Fig. 4

4. Remove the repair window (see Fig. 5).

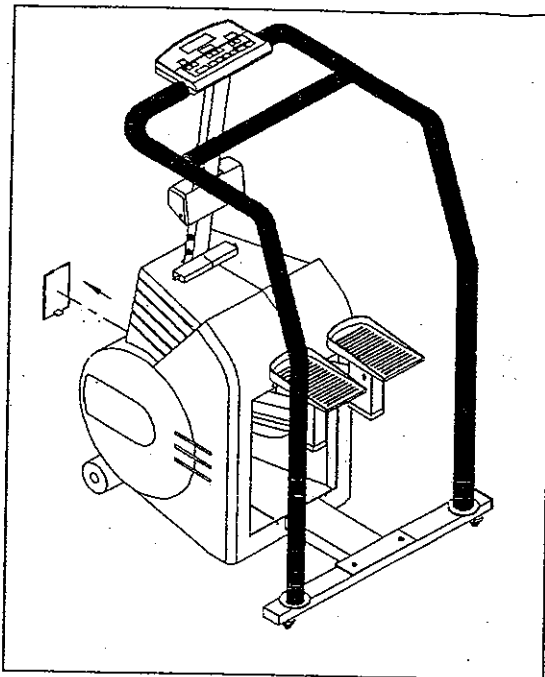

Fig5. (7003)

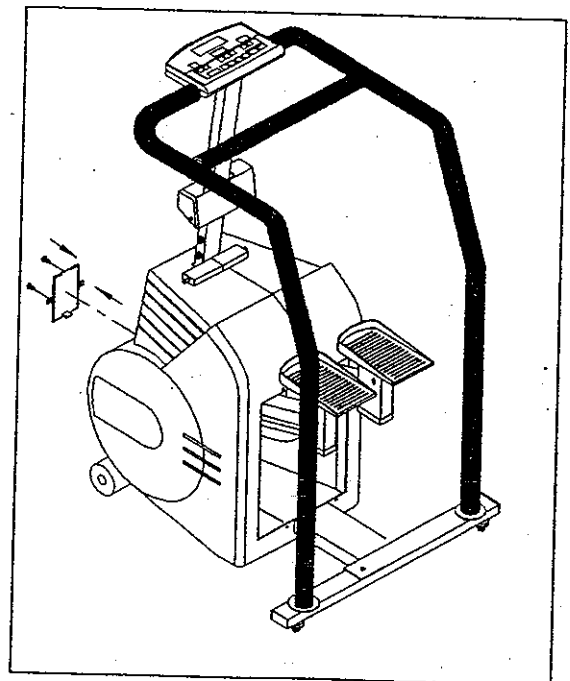

Fig5. (7003/7003B/7003C/7003N)

5. Remove the nine screws securing the main shroud (see Fig. 6).

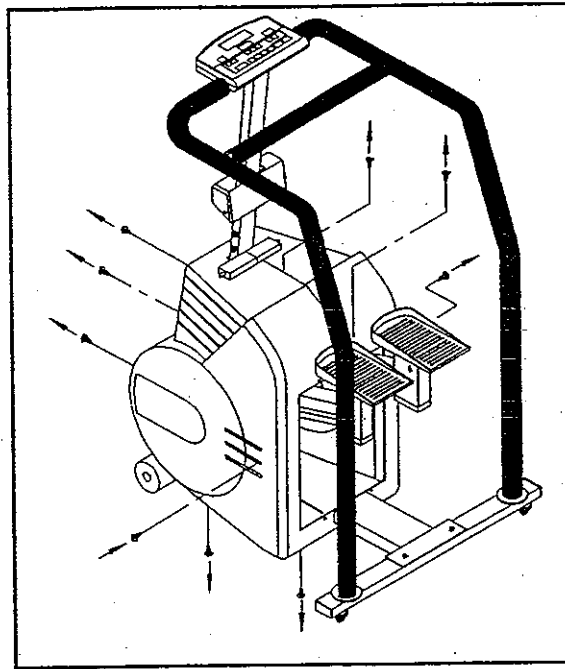

Fig. 6

6. Remove the main shroud (see Fig. 7).

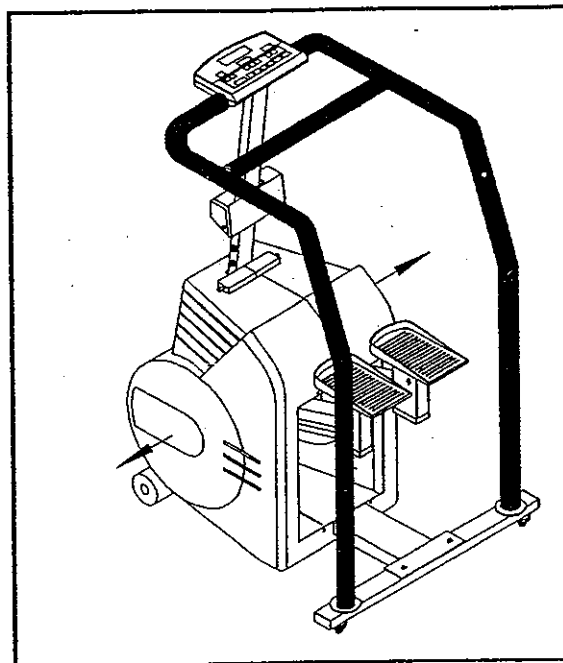

Fig. 7

7. Raise up the springs to release both sides, following steps A and B (see Fig. 8).

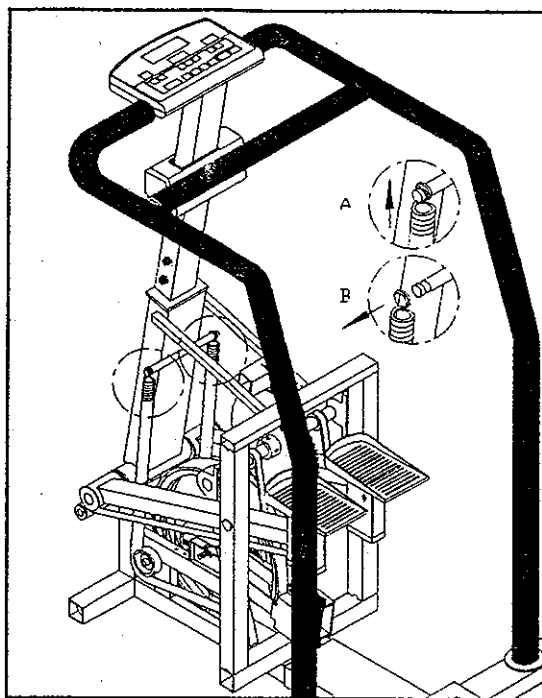

Fig. 8

8. Lower the foot pads to their lowest position, then slide out the springs (see Fig. 9).

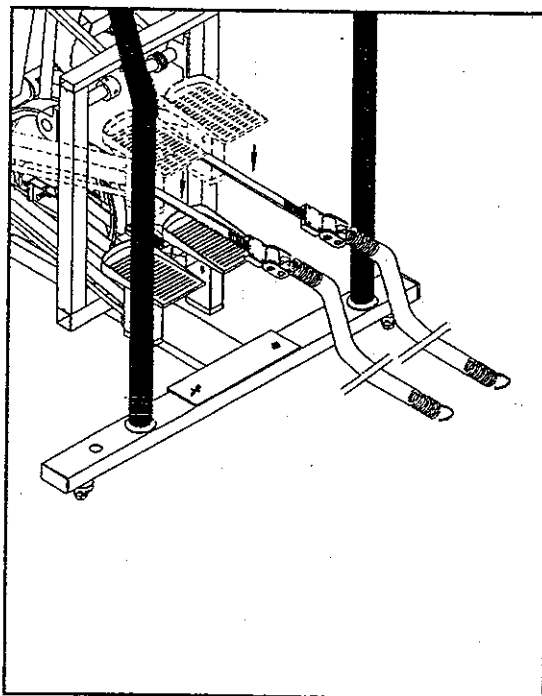

Fig. 9

For 7003 & 7003C

9. Find the chain connector, then use a clip to remove it. Then remove the disconnected chain (see Fig. 10-12).

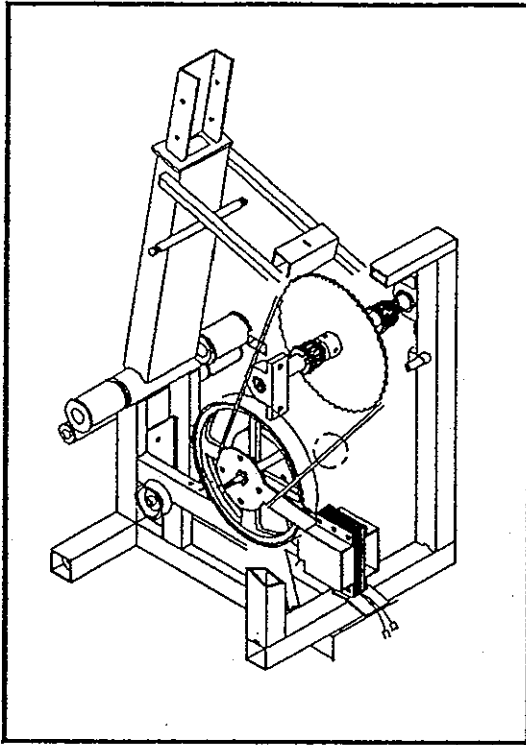

Fig. 10

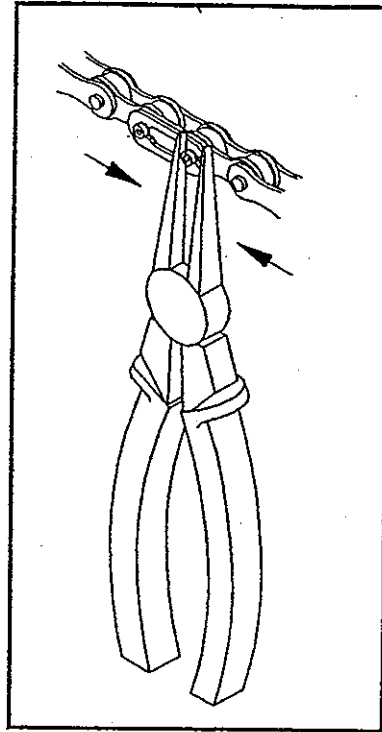

Fig. 11

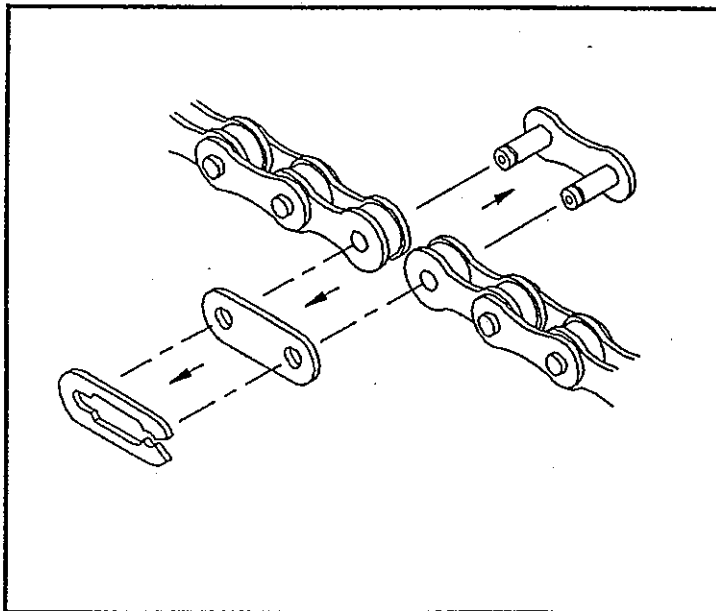

Fig. 12

10. Remove the two screws and washers securing the bearing (pillow block) on each side (see Fig. 13).

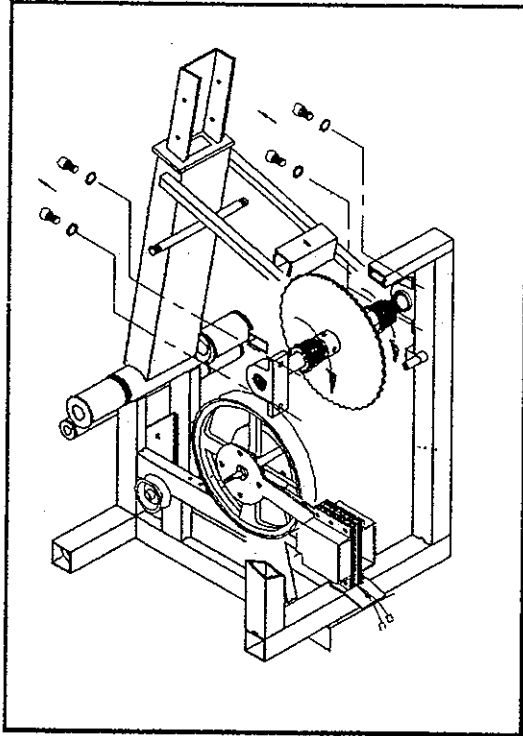

Fig. 13 (7003/7003C)

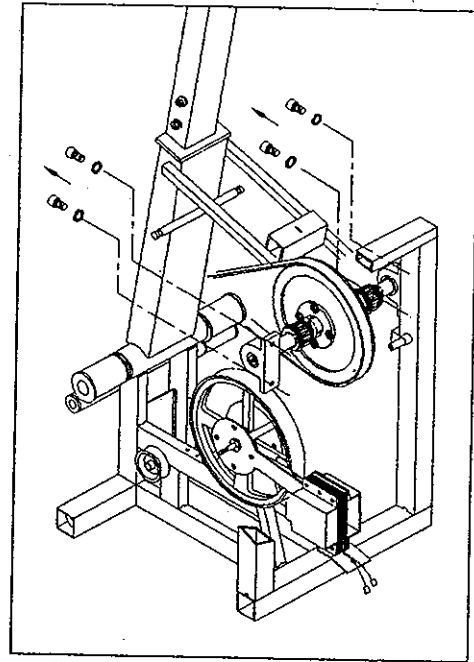

Fig. 13 (7003B/7003N)

11. Remove the two screws on the surface of the gear shaft, and one screw and washer securing the center of the gear shaft on both side (see Fig. 14).

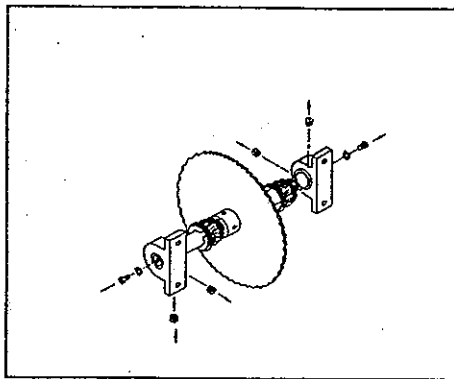

Fig14. (7003/7003C)

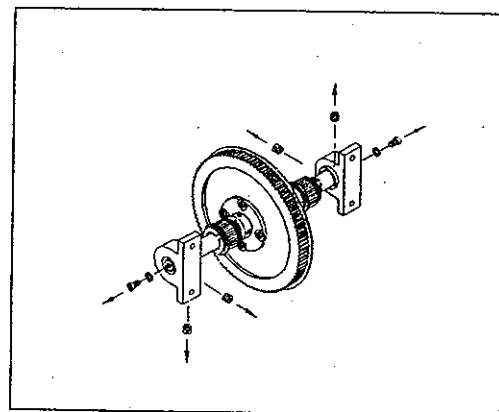

Fig14. (7003B/7003N)

12. Remove both bearings (pillow block) (see Fig. 15).

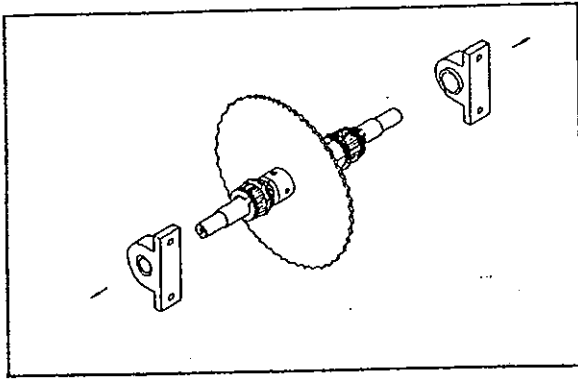

Fig15. (7003/7003C)

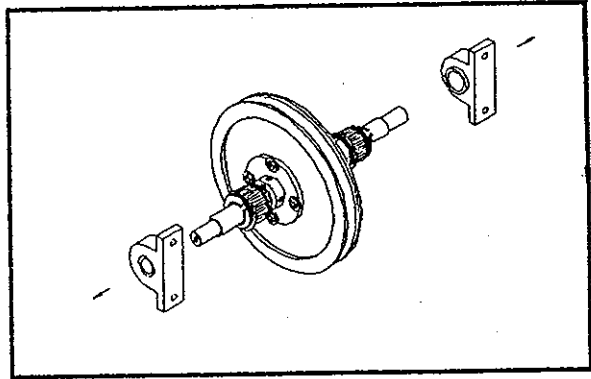

Fig15. (7003B/7003N)

13. Use a clip to remove the C-ring securing the gear shaft on each side (see Fig. 16).

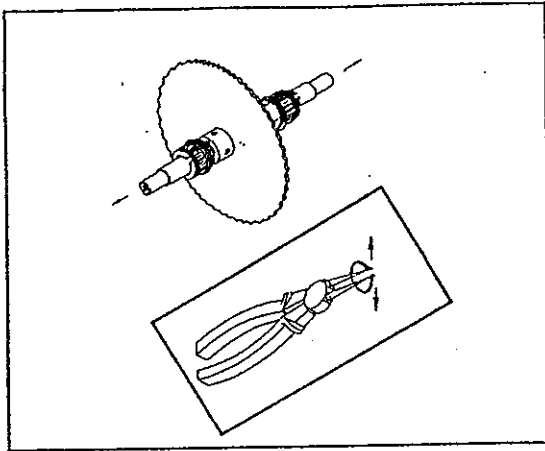

Fig16. (7003/7003C)

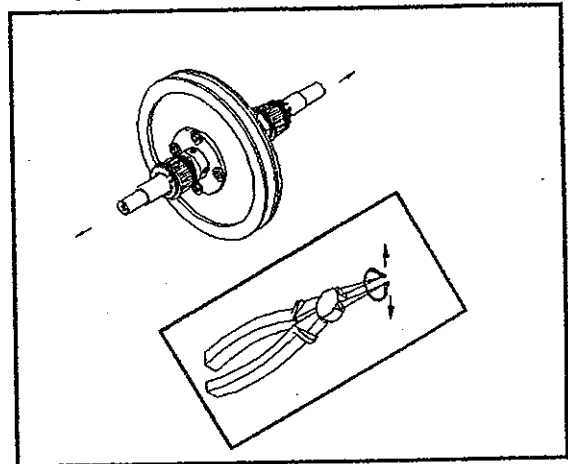

Fig16. (7003B/7003N)

14. Remove all the parts from the gear shaft on each side (see Fig. 17). Remove the chain wheel and the gear shaft.

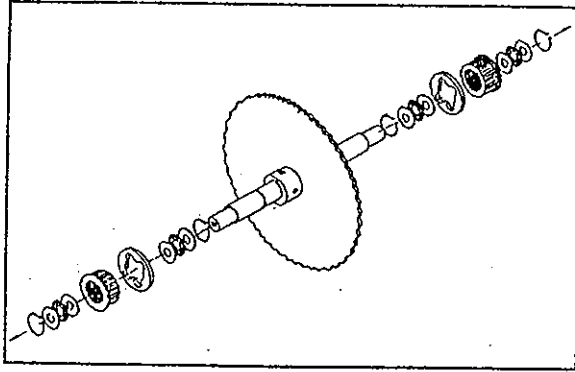

Fig17. (7003/7003C)

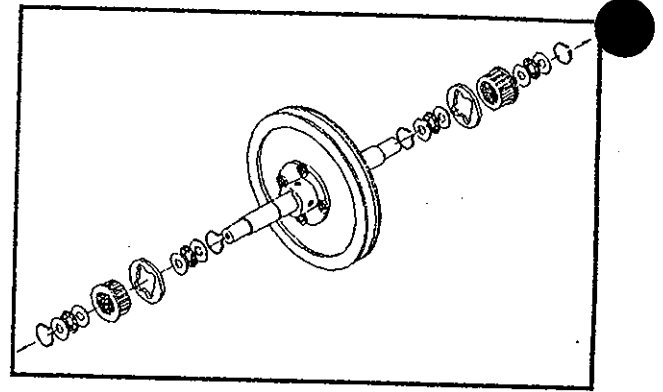

Fig17. (7003B/7003N)

To install:

1. Install the new chain wheel and gear shaft, and reassemble all the parts from the gear shaft, make sure all the parts in their correct positions, follow the steps as shown in Fig. 18. Otherwise, there is no tension while you are climbing.

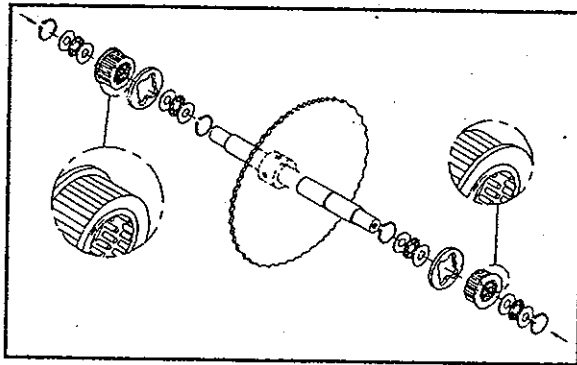

Fig18. (7003/7003C)

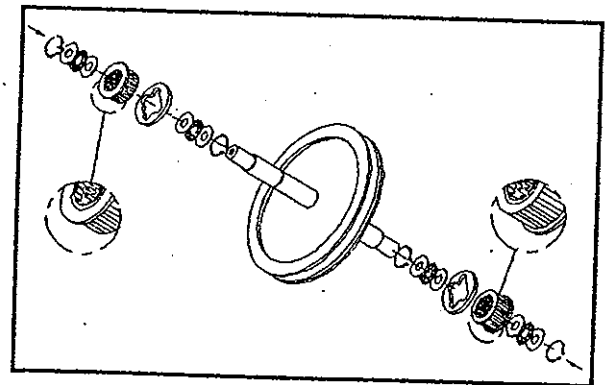

Fig18. (7003B/7003N)

2. Use a clip to fasten the C-ring into place (see Fig. 19).

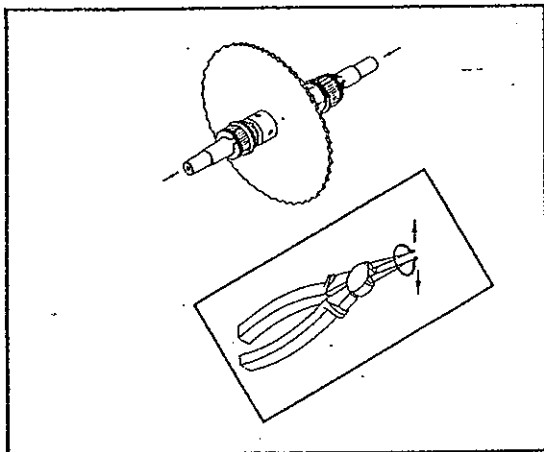

Fig19. (7003/7003C)

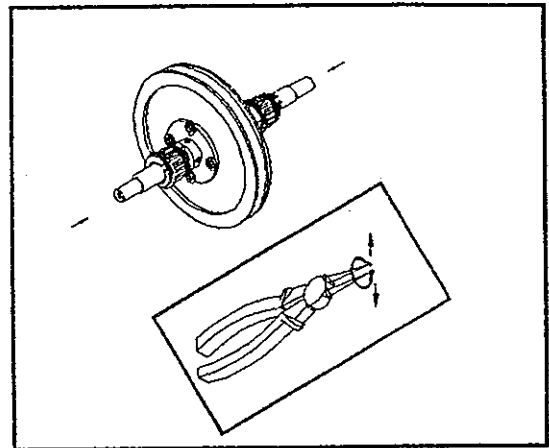

Fig19. (7003B/7003N)

3. Assemble both sides of the bearings (pillow block) back into position (see Fig. 20).

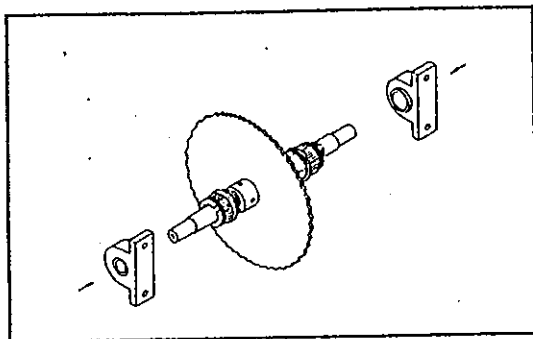

Fig20. (7003/7003C)

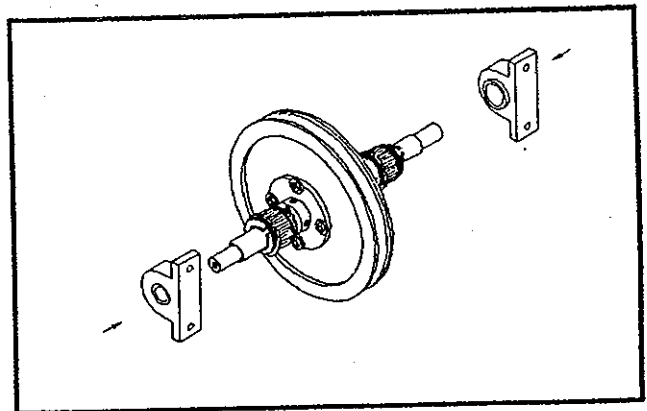

Fig20. (7003B/7003N)

- Secure the two set screws to the gear shaft on the shaft surface. Then tighten one screw with washer to the center of the gear shaft (see Fig. 21).

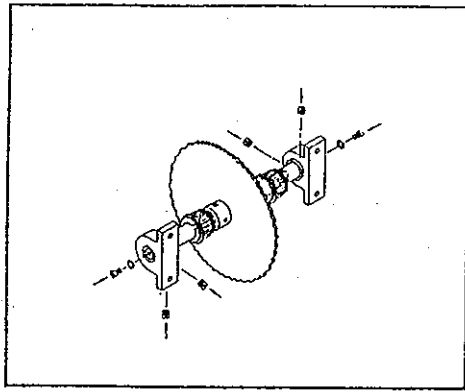

Fig21. (7003/7003C)

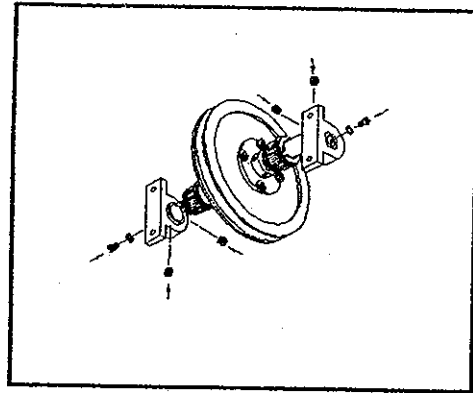

Fig21. (7003B/7003N)

For 7003 & 7003C

- Put the gear shaft into place, and tighten the two screws and washers on each side.

Use a specific gauge to make sure the gear shaft is proper aligned between the two wheels.

Loosen the screw, adjust the chain wheel to align with small chain wheel properly, then secure with screw (see Fig. 22).

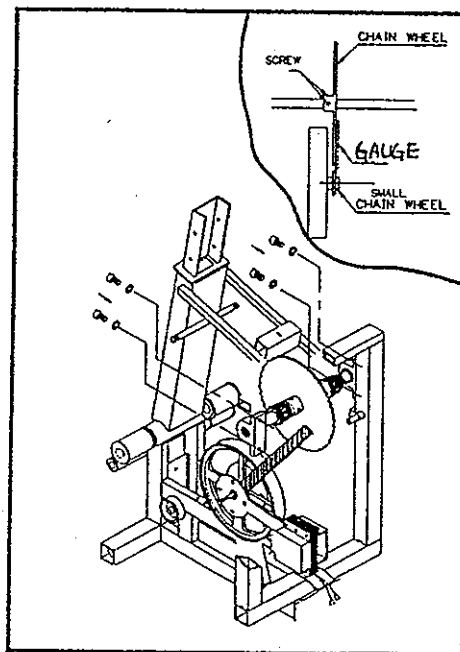

Fig. 22

6. Connect the chain with connector, washer, and holder. Use a clip to secure the chain. (see Fig. 23-25).

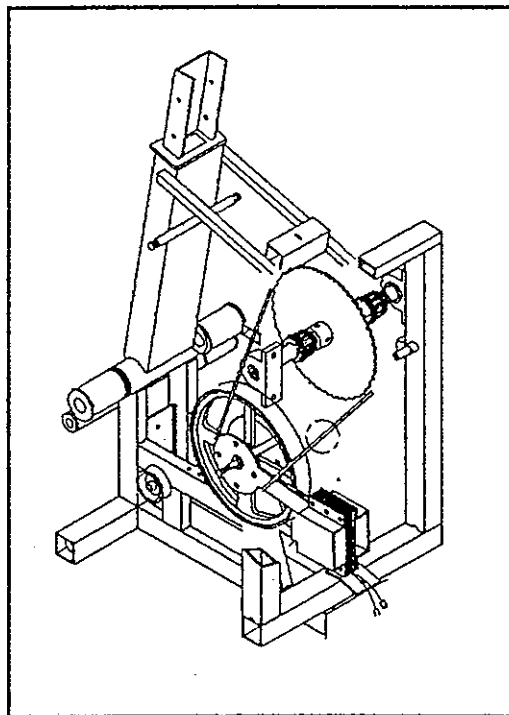

Fig. 23

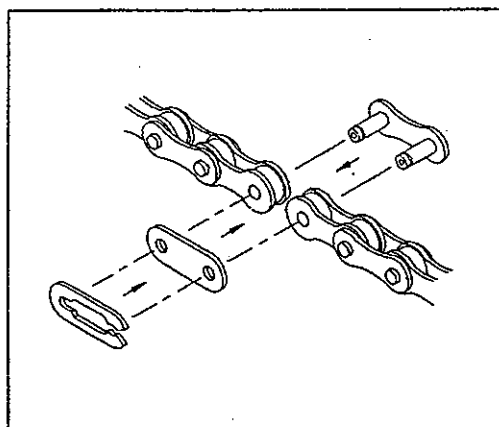

Fig. 24

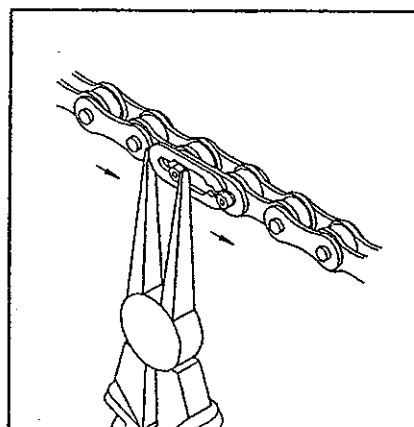

Fig.25

For 7003B & 7003N

6. Assemble the flywheel's poly-V belt over the gear shaft (see Fig. 25A.1).

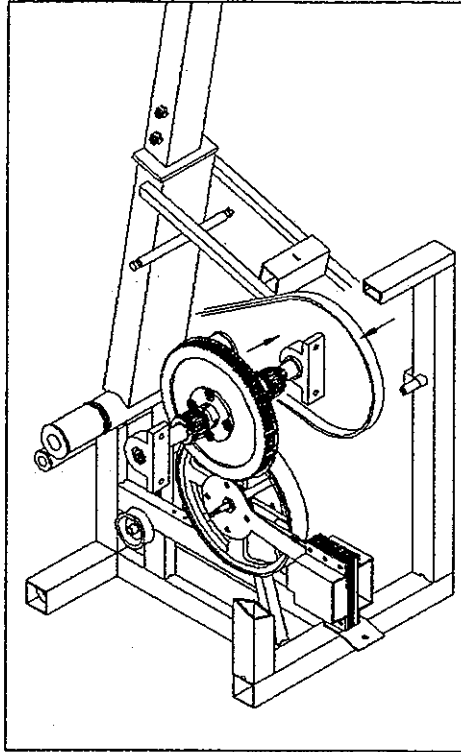

Fig.25A-1

6-1. Assemble both sides of the bearings (pillow block) back into position (see Fig. 25A-2).

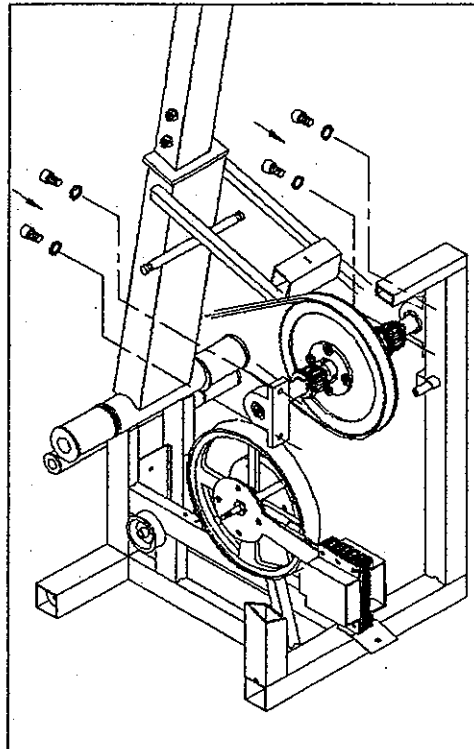

Fig.25A-2

6-2. Make sure the gear shaft wheel with idler pulley aligned. And the correct gap between the idler pulley and flywheel should be 5-6mm (see Fig 25A-3).

6-3. If the gap need to be adjusted, use a hex Allen wrench to release both sides of the gear shaft screws, adjust the gear wheel until the correct gap shows, then secure both screws (see Fig. 25A-4).

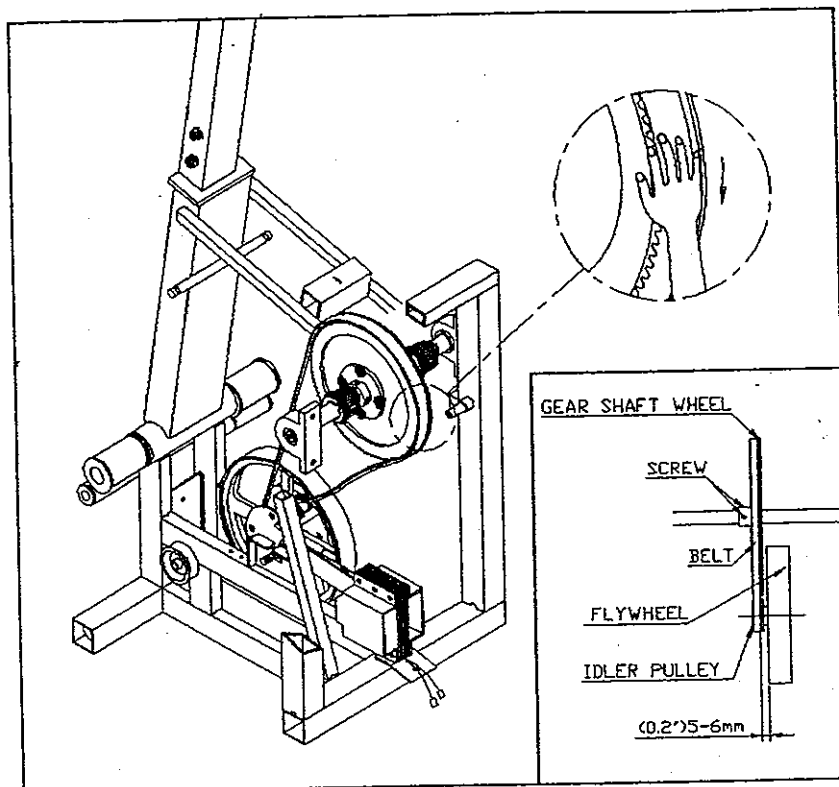

Fig.25A-3

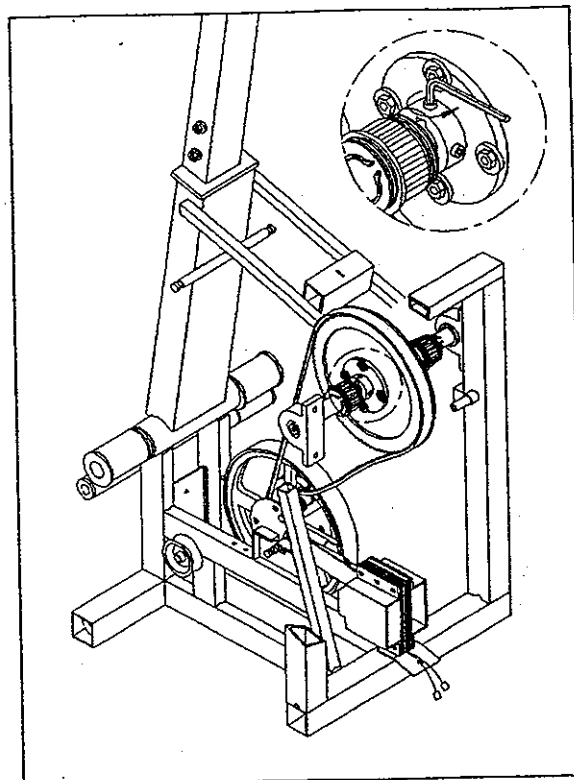

Fig.25A-4

7. Raise both foot pads to their highest positions. Match the teeth of the poly-V belt into the gear teeth (see Fig. 26 & 27).

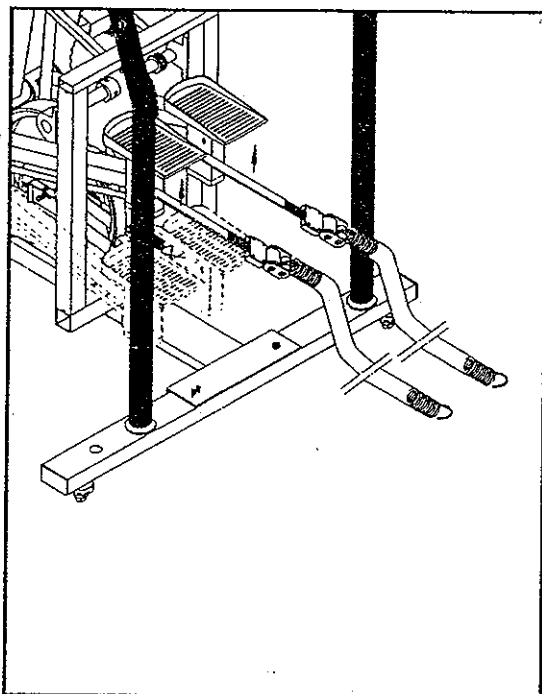

Fig.26

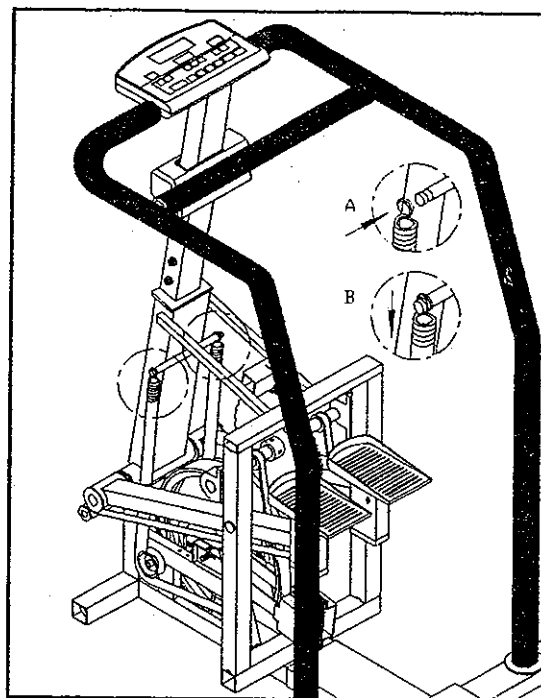

Fig.27

8. Secure the two springs in their correct positions, following steps A and B (see Fig. 27).

9. Replace the main shroud and tighten with screws (see Fig. 28 & 29).

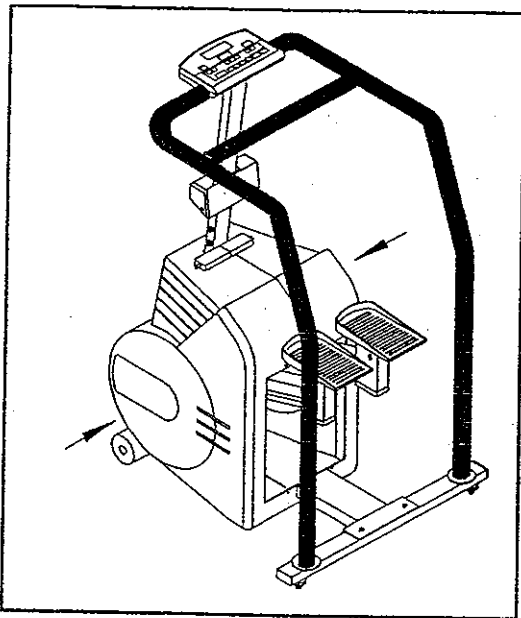

Fig.28

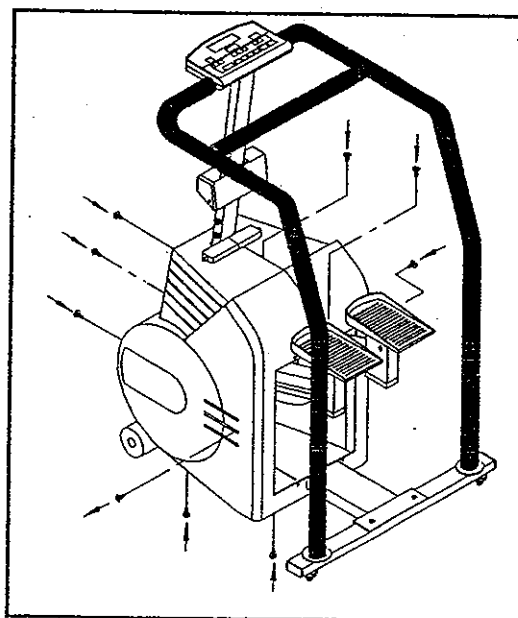

Fig.29

10. Replace the repair window back into position (see Fig. 30).

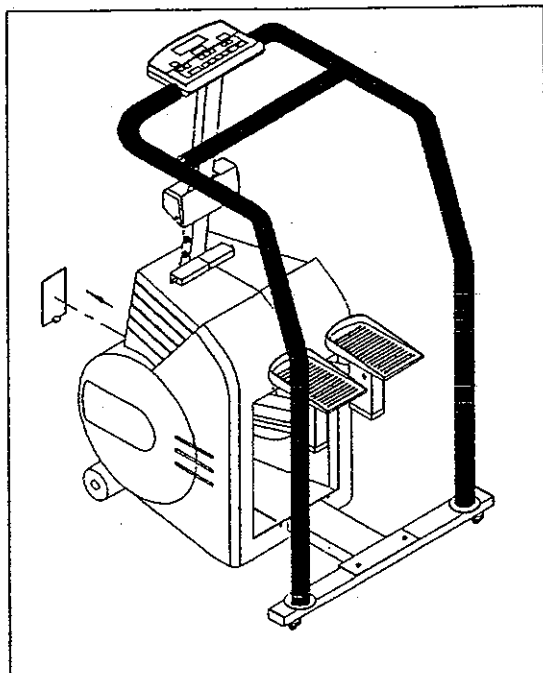

Fig 30. (7003)

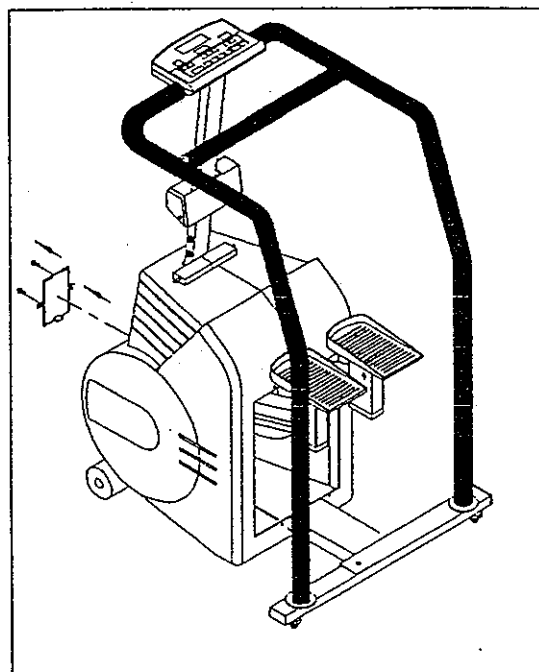

Fig 30. (7003/7003B/7003C/7003N)

11. Secure the front cover with screws (see Fig. 31).

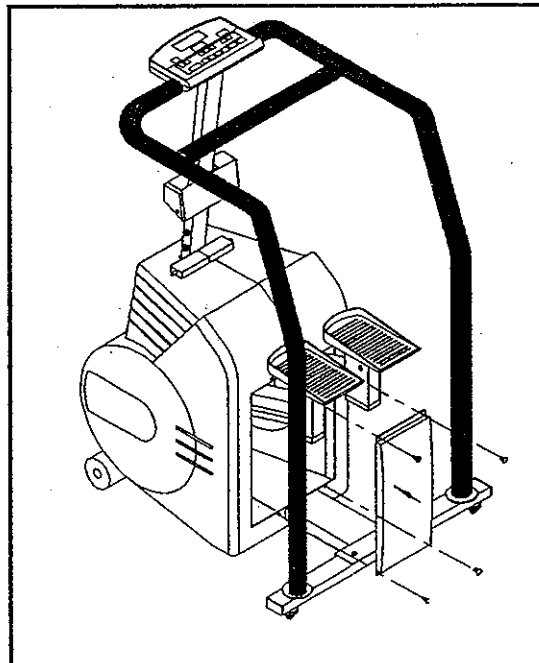

Fig.31

12. Replace the transport wheels, tighten with screws and washers, then cover with labels (see Fig. 32).

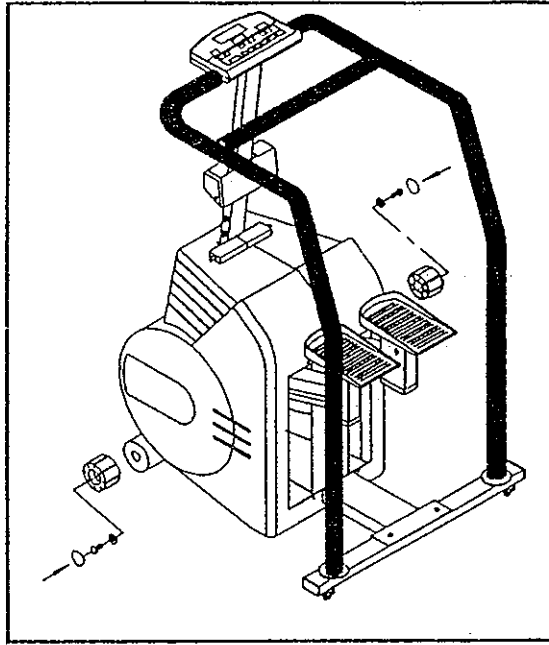

Fig.32

13. Replace the post shroud, secure with two screws (see Fig. 33 & 34).

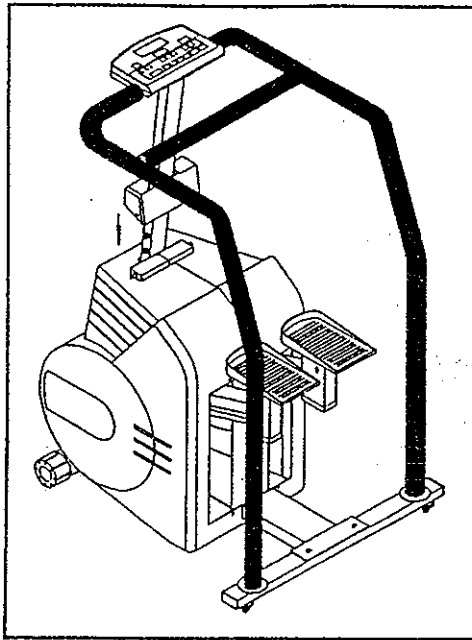

Fig.33

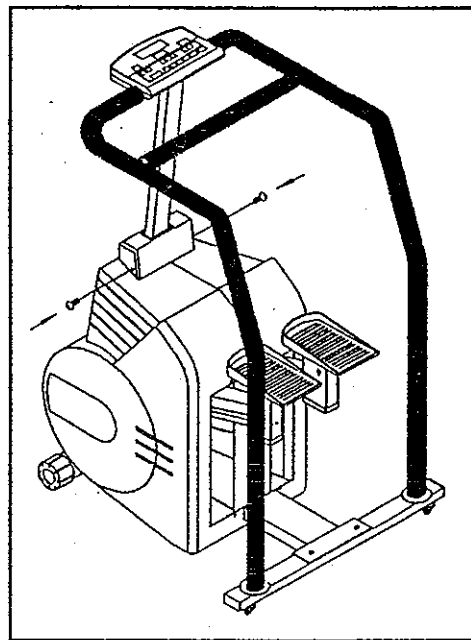

Fig.34

P. STAIR ARM BELT REMOVAL AND INSTALLATION PROCEDURE

1. Remove the two screws securing the post shroud (see Fig. 1 & 2).

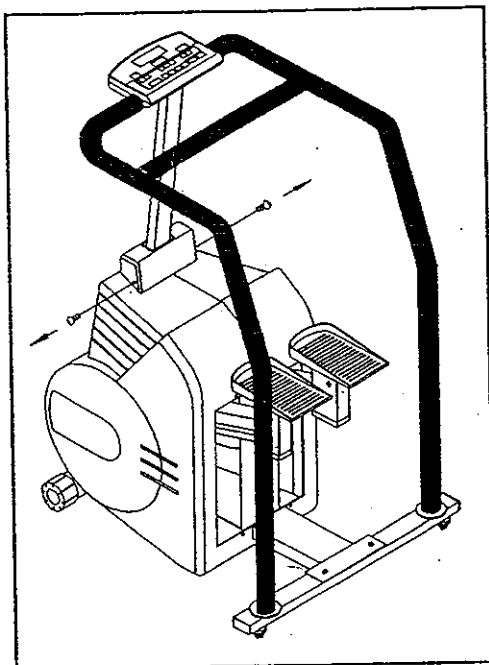

Fig.1

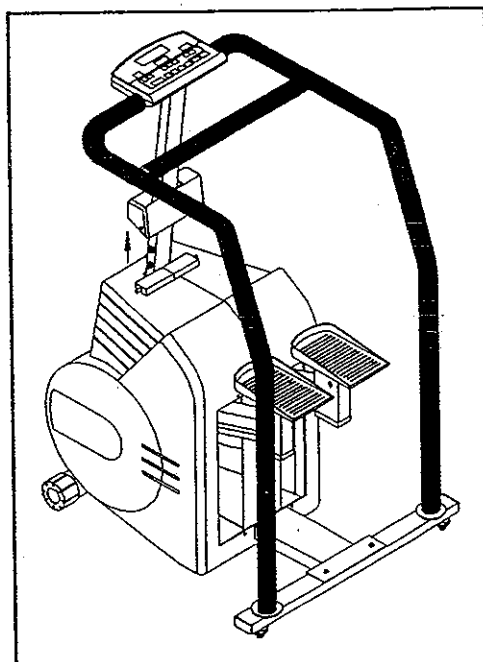

Fig. 2

2. Remove the transport wheel labels first, then unscrew the transport wheels on the front of the stair climber. Remove both wheels (see Fig. 3).

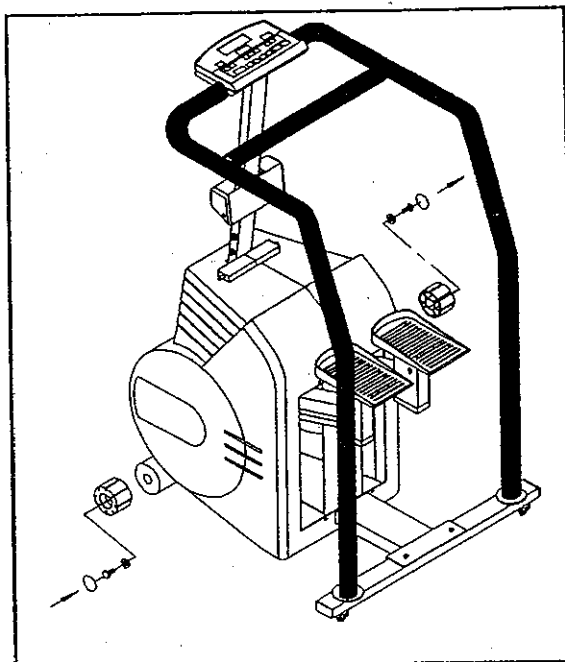

Fig. 3

3. Remove the four screws securing the front cover (see Fig. 4).

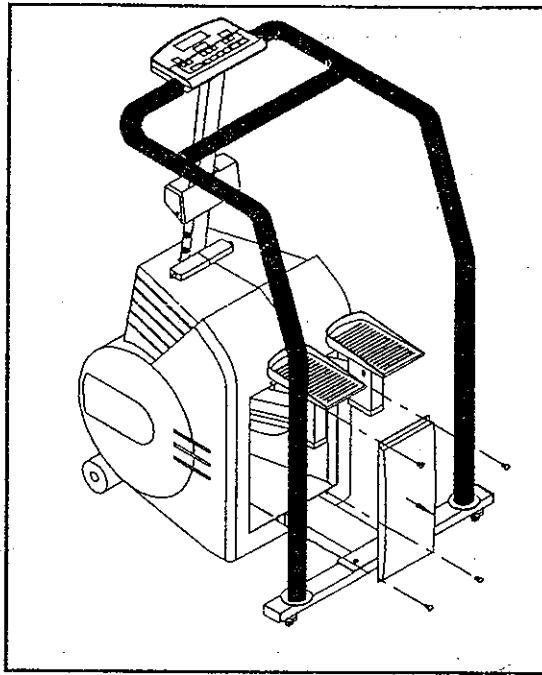

Fig. 4

4. Remove the repair window (see Fig. 5).

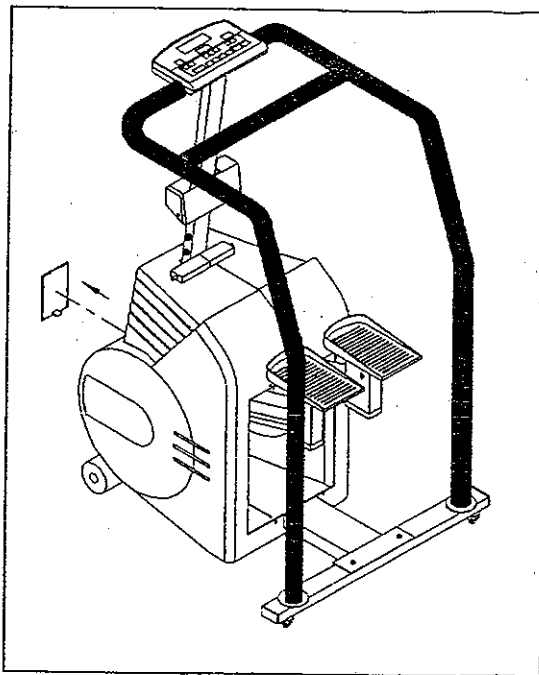

Fig 5. (7003)

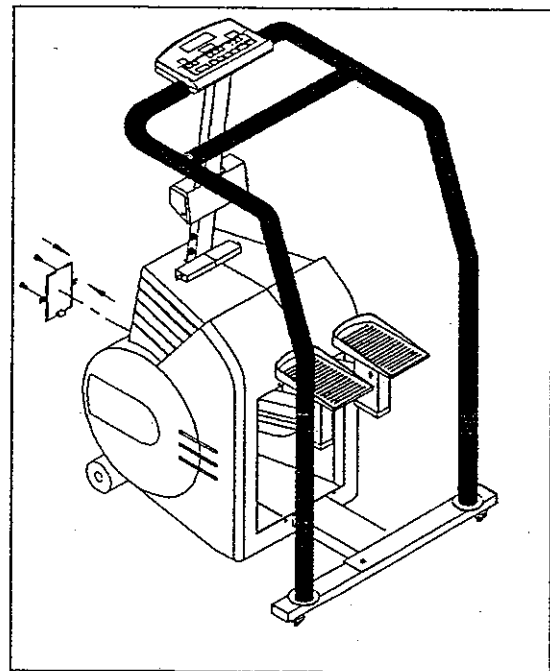

Fig 5. (7003/7003B/7003C/7003N)

5. Remove the nine screws securing the main shroud (see Fig. 6).

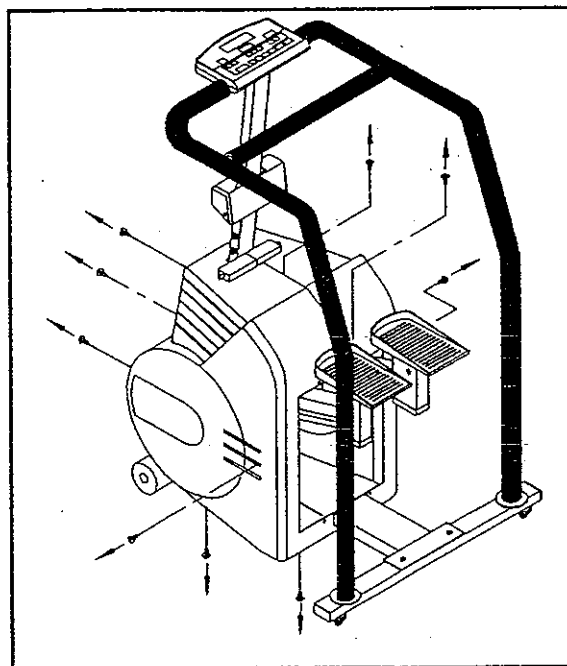

Fig. 6

6. Remove the main shroud (see Fig. 7).

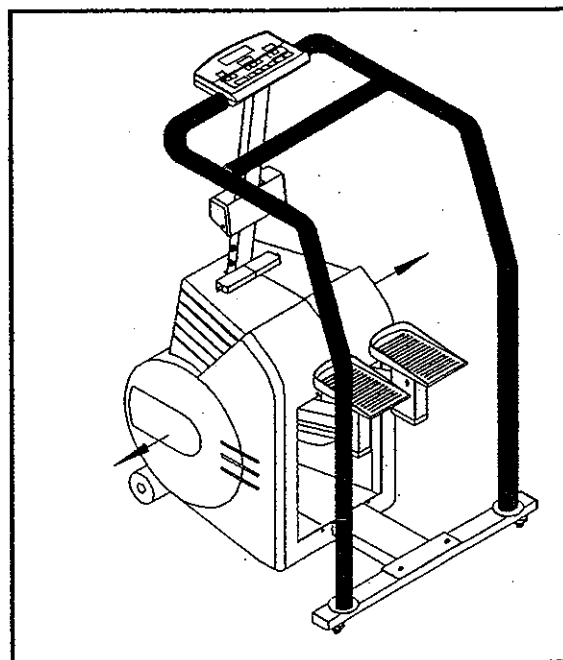

Fig. 7

7. Raise up the springs to release both sides, following steps A and B (see Fig. 8).

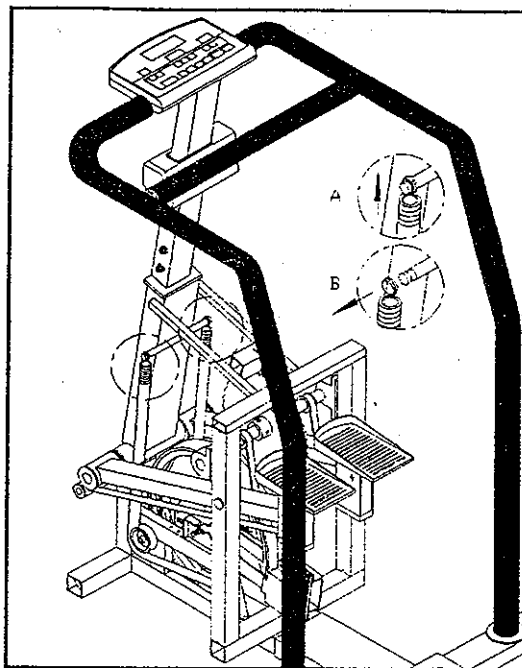

Fig. 8

8. Lower the foot pads to their lowest position, then slide out the springs (see Fig. 9)

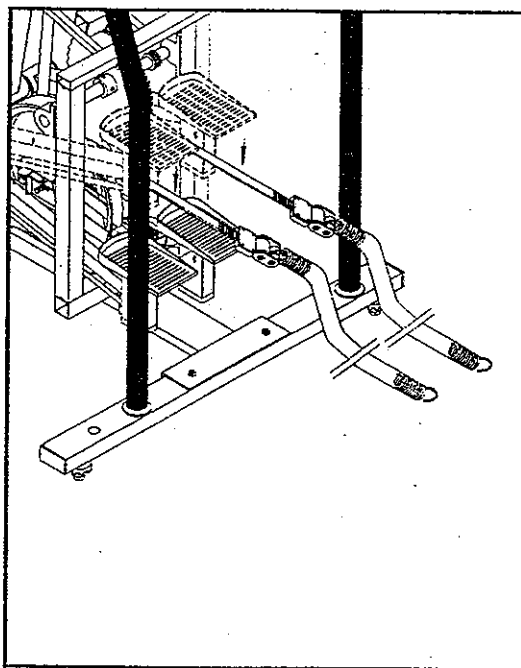

Fig. 9

9. Remove the screw and washer securing the belt to the stair arm.

Remove the belt (see Fig. 10).

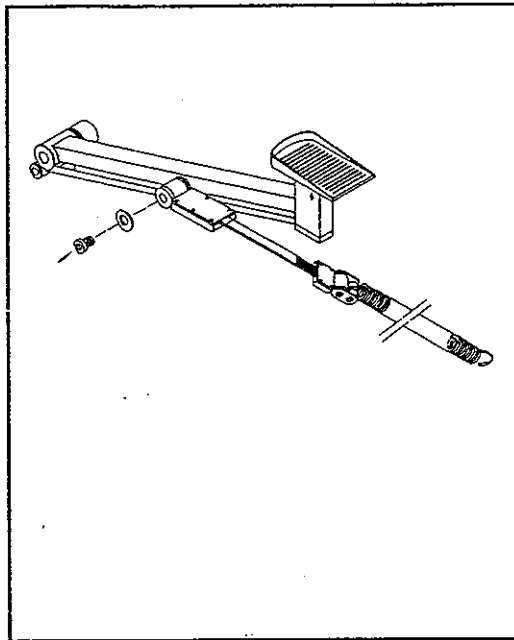

Fig. 10

10. Find the connector which connects the belt and the spring. Then, unscrew the two screws and washers on both sides of the connector (see Fig. 11).

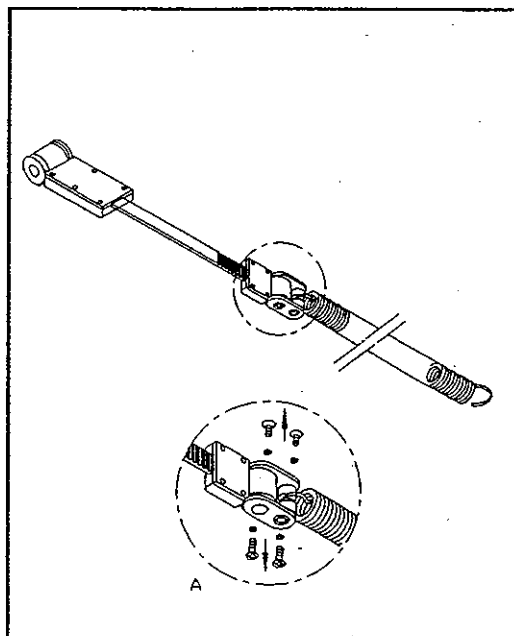

Fig. 11

11. Disassemble following the steps in Fig. 12.

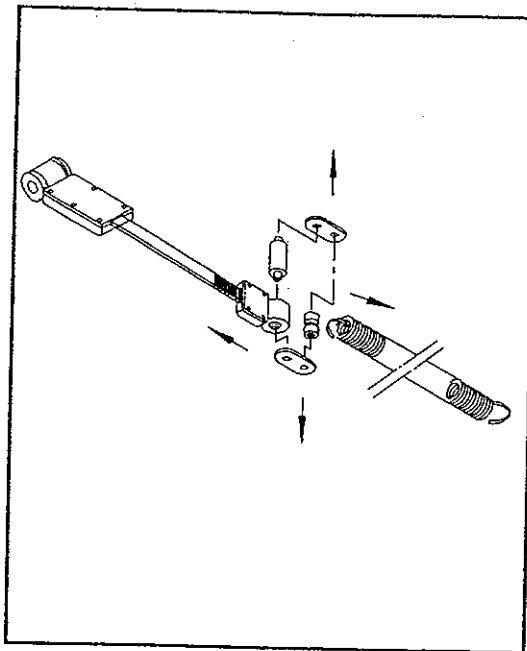

Fig. 12

To install:

1. Install a new belt and reassemble all the parts as shown in Fig. 13.

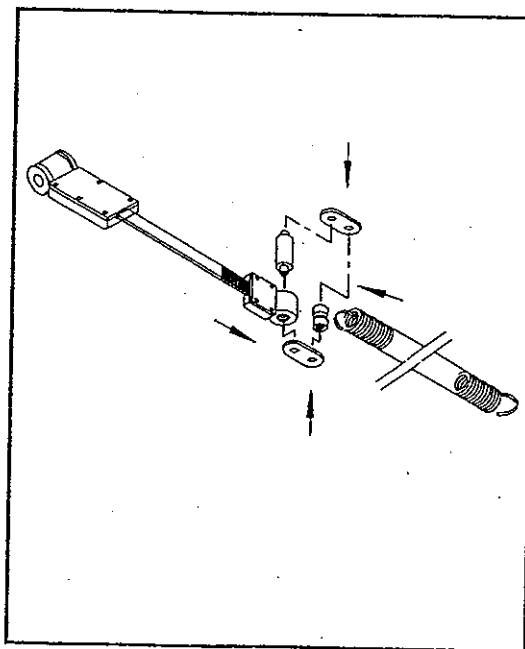

Fig. 13

2. Connect the belt to the spring securely with two screws and washers on both sides (see Fig. 14).

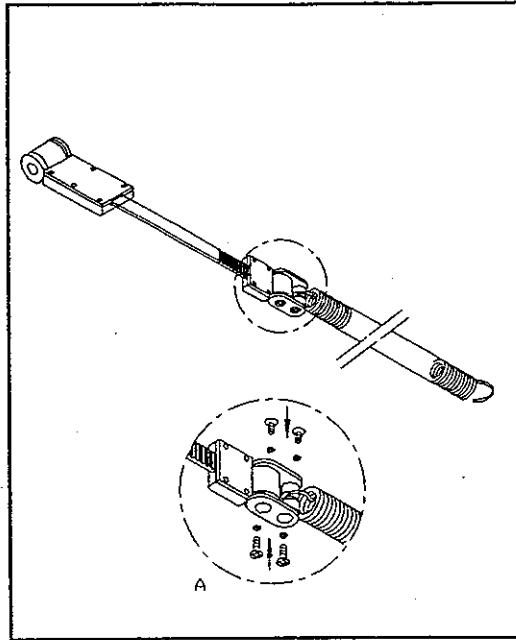

Fig. 14

3. Secure the belt to the stair arm with the screw and washer (see Fig. 15).

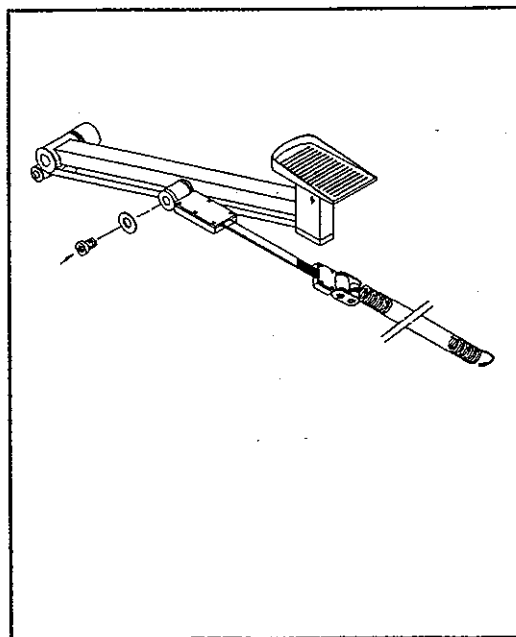

Fig. 15

4. Raise both foot pads to their highest positions. Match the teeth of the belt into the gear teeth (see Fig. 16 & 17).

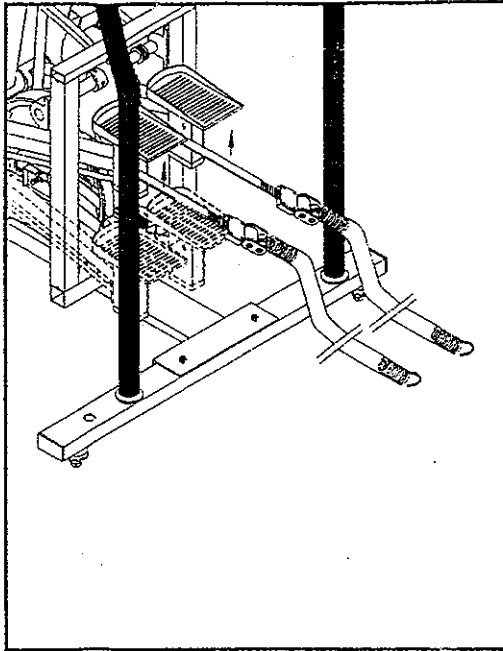

Fig. 16

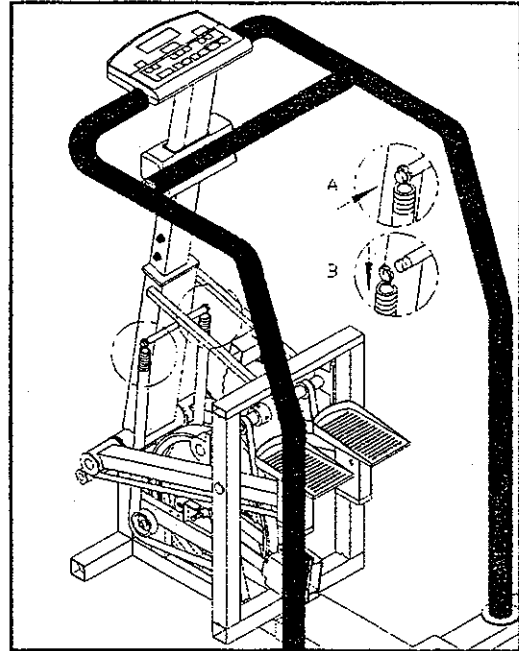

Fig. 17

5. Secure the two springs in their correct positions, following steps A and B (see Fig. 17).

6. Replace the main shroud and tighten with screws (see Fig. 18 & 19).

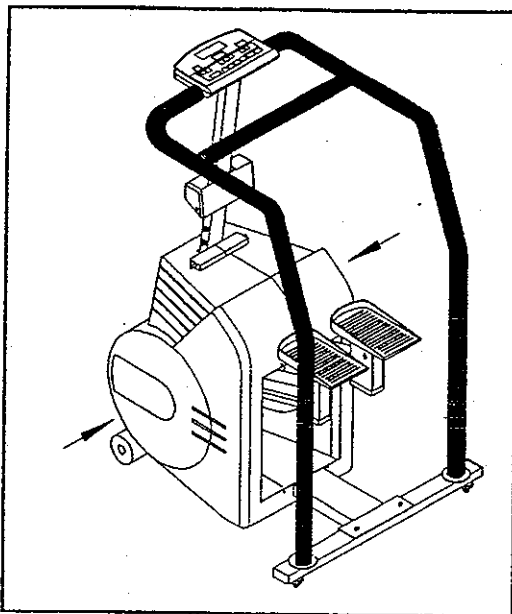

Fig. 18

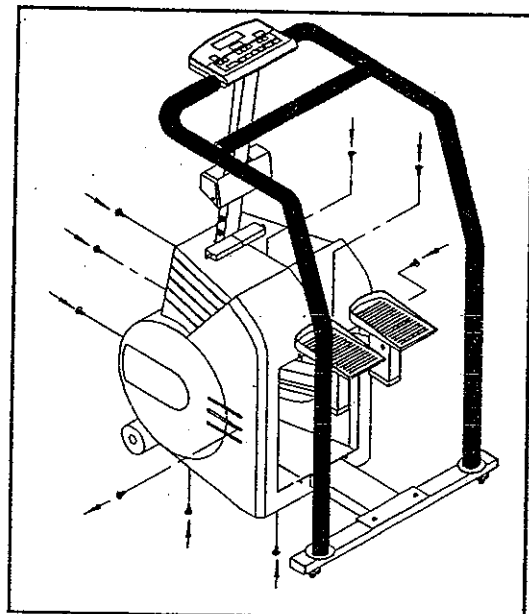

Fig. 19

7. Place the repair window into position (see Fig. 20).

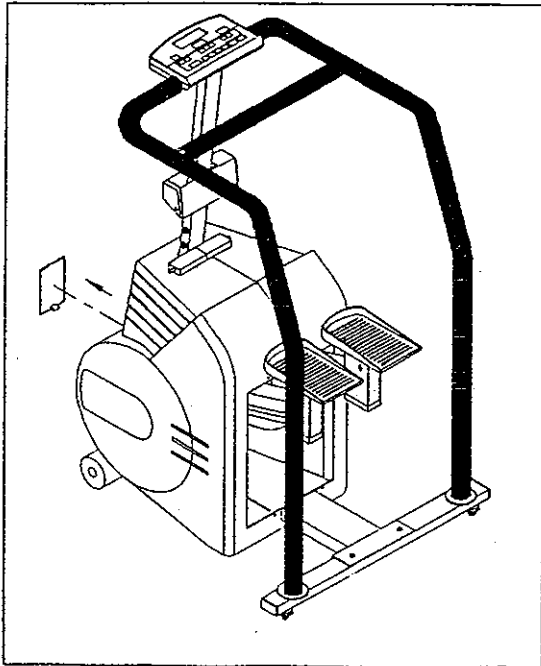

Fig 20. (7003)

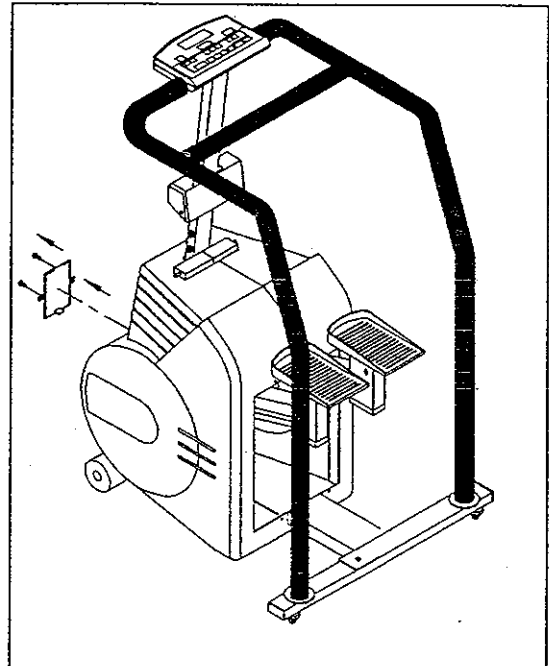

Fig 20. (7003/7003B/7003C/7003N)

8. Secure the front cover with four screws (see Fig. 21).

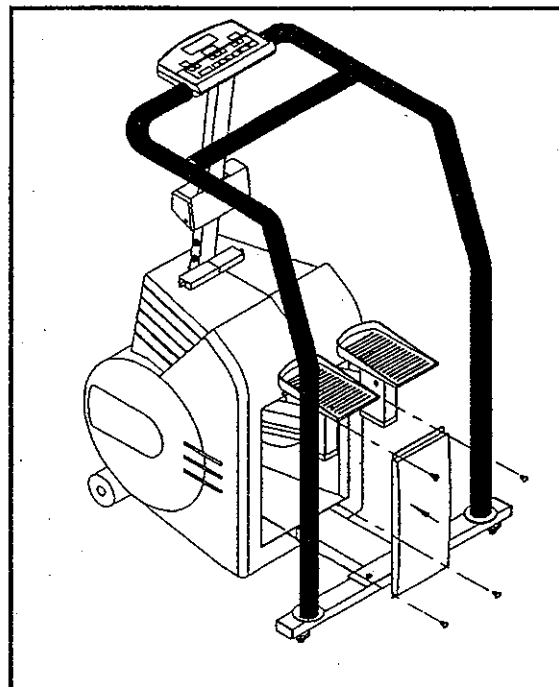

Fig. 21

9. Replace the transport wheels, tighten with screws and washers; then cover with labels (see Fig. 22).

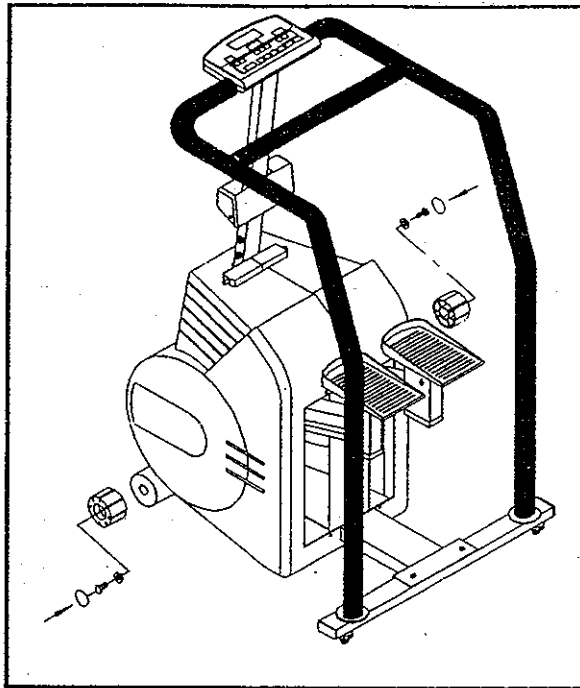

Fig. 22

10. Replace the post shroud, secure with two screws (see Fig. 23 & 24).

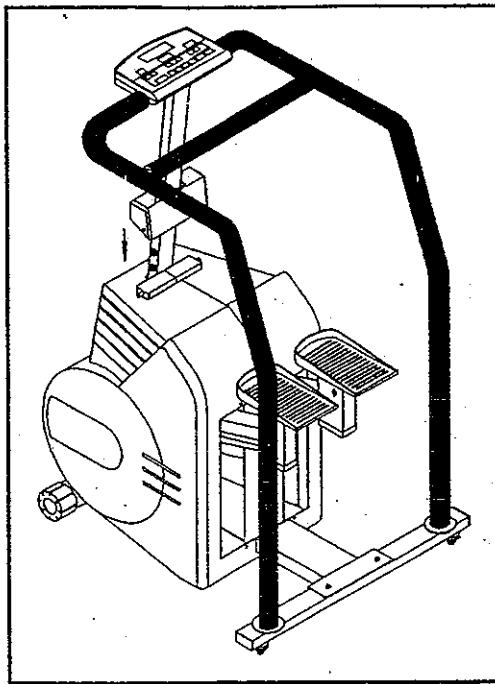

Fig. 23

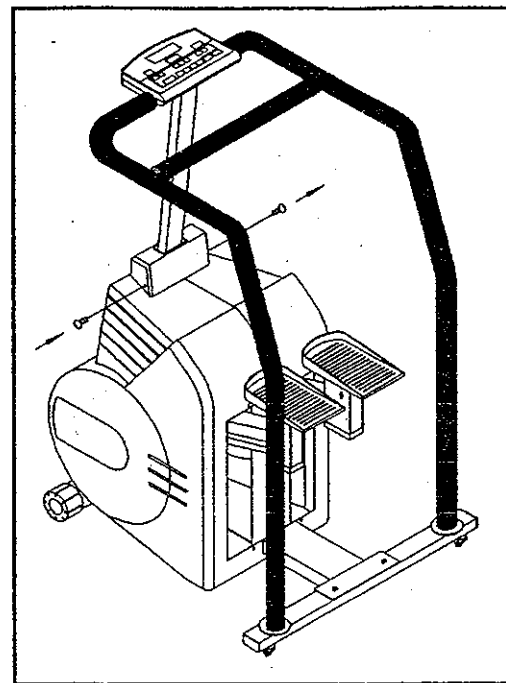

Fig. 24

Q. SPRING REMOVAL AND INSTALLATION PROCEDURE

1. Remove the two screws securing the post shroud (see Fig. 1 & 2).

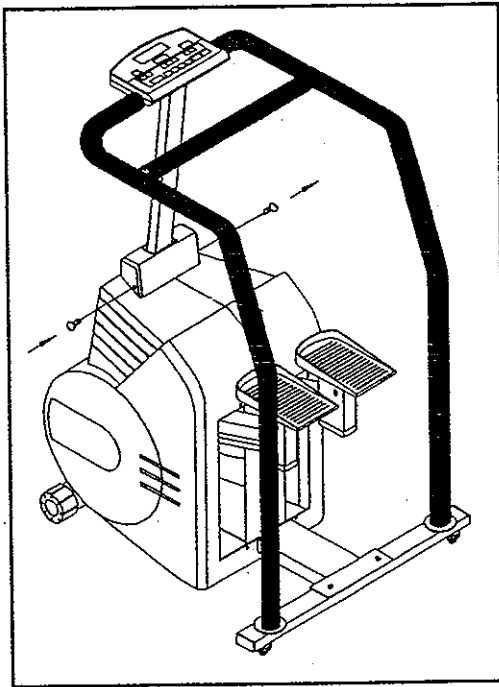

Fig.1

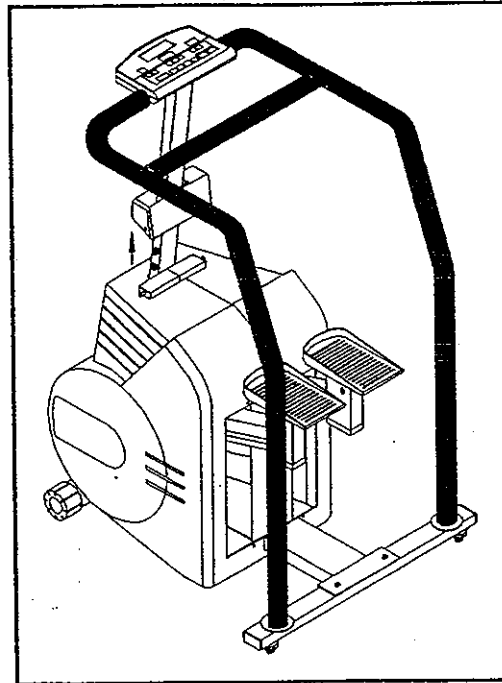

Fig. 2

2. Remove the transport wheel labels first, then unscrew the transport wheels on the front of the stair climber. Remove both wheels (see Fig. 3).

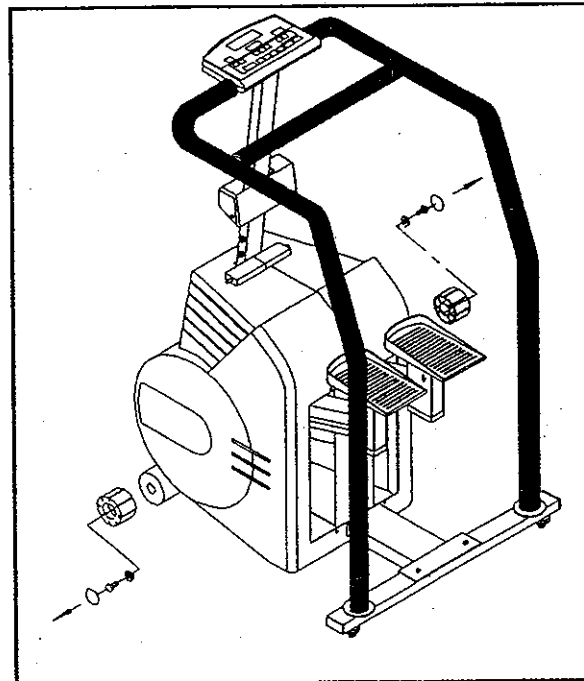

Fig. 3

3. Remove the four screws securing the front cover (see Fig. 4).

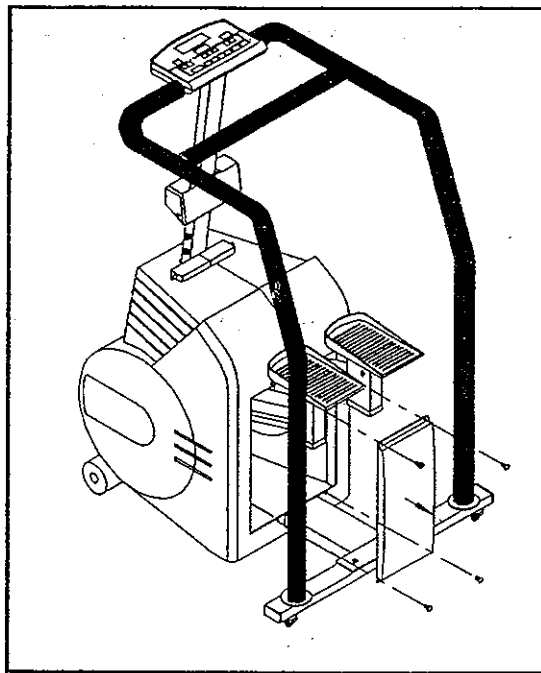

Fig. 4

4. Remove the repair window (see Fig. 5).

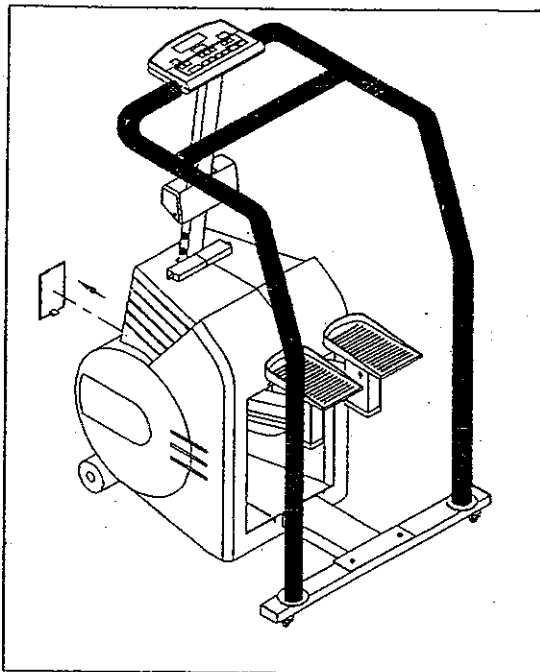

Fig 5. (7003)

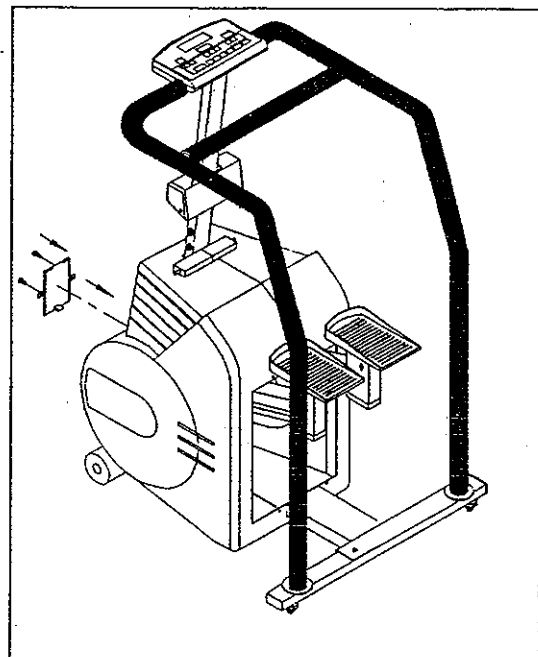

Fig 5. (7003/7003B/7003C/7003N)

5. Remove the nine screws securing the main shroud (see Fig. 6).

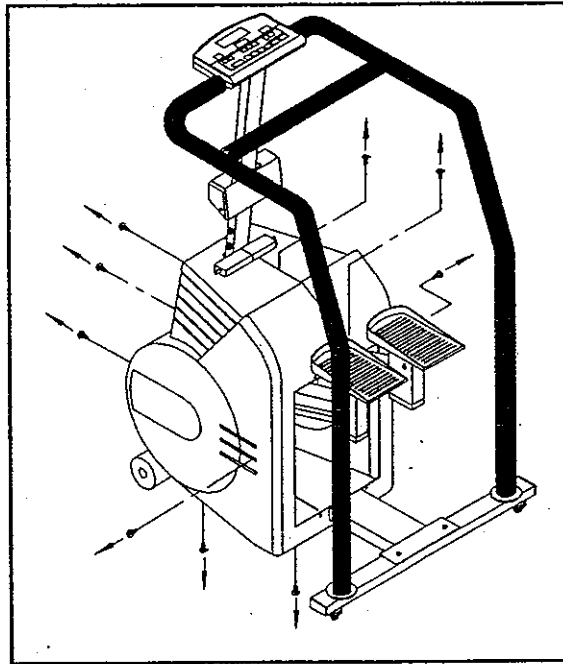

Fig. 6

6. Remove the main shroud (see Fig. 7).

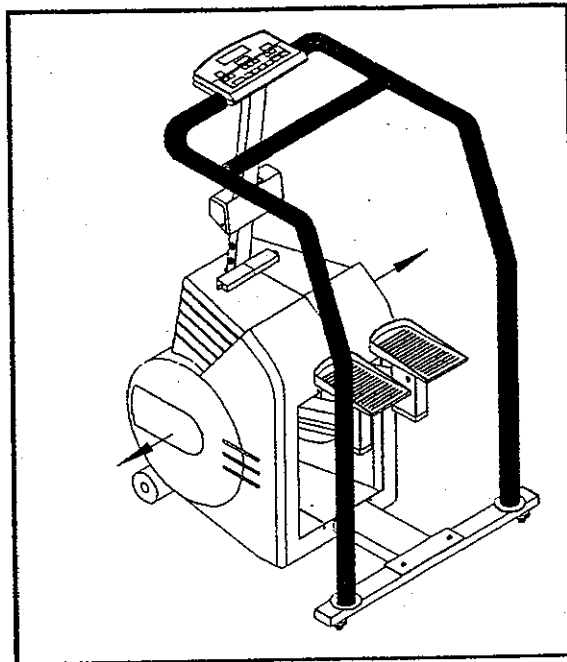

Fig. 7

7. Raise up the springs to release both sides, following steps A and B (see Fig: 8).

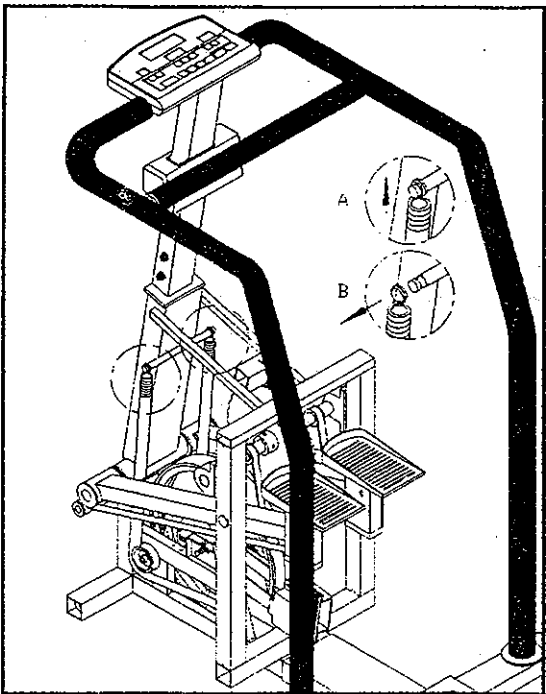

Fig. 8

8. Lower the foot pads to their lowest position, then slide out the springs (see Fig. 9)

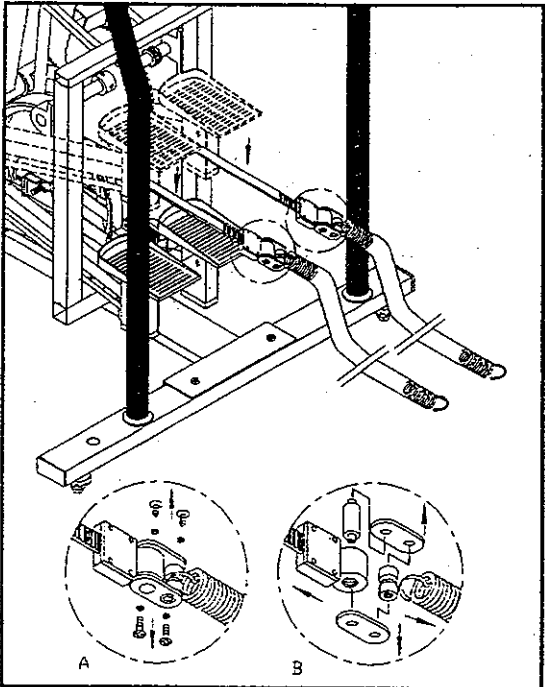

Fig. 9

Find the connector which connects the stair arm belt and the spring. Then, unscrew the two screws and washers on both sides of the connector (see Fig. 9A).

Disassemble following the steps in Fig. 9B.

To install:

1. Replace a new spring. Connect the stair arm belt to the spring securely with two screws and washers on both sides.

Reassemble all the parts as shown in Fig. 10 to 10B.

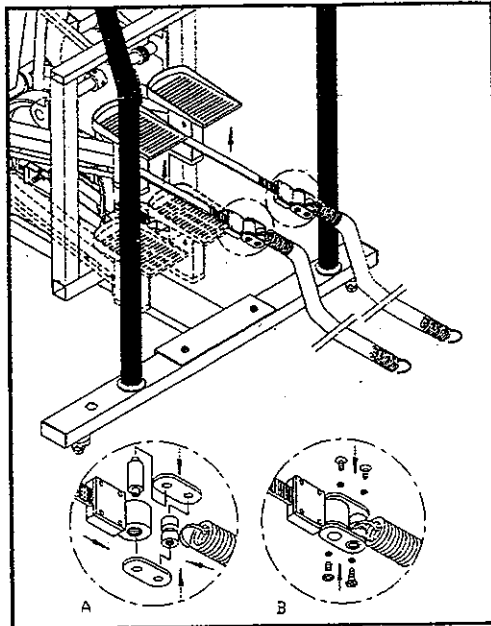

Fig. 10

2. Raise both foot pads to their highest positions. Match the teeth of the stair arm belt into the gear teeth.

Secure the two springs in their correct positions, following steps A and B (see Fig. 11).

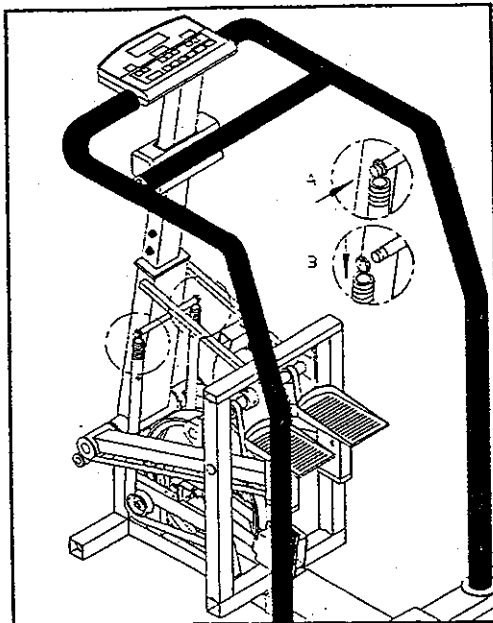

Fig. 11

3. Replace the main shroud and tighten with screws (see Fig. 12 & 13).

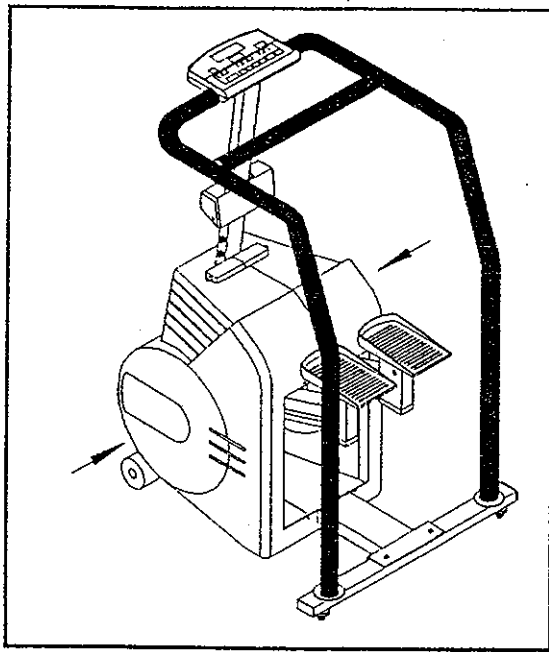

Fig. 12

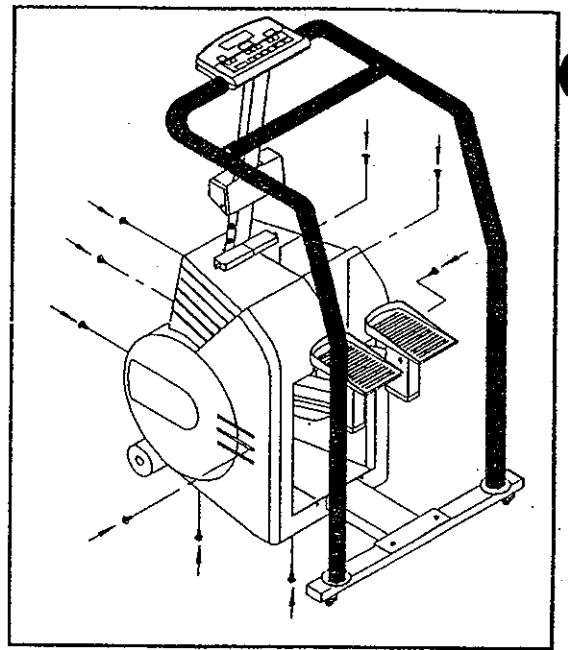

Fig. 13

4. Place the repair window into position (see Fig. 14).

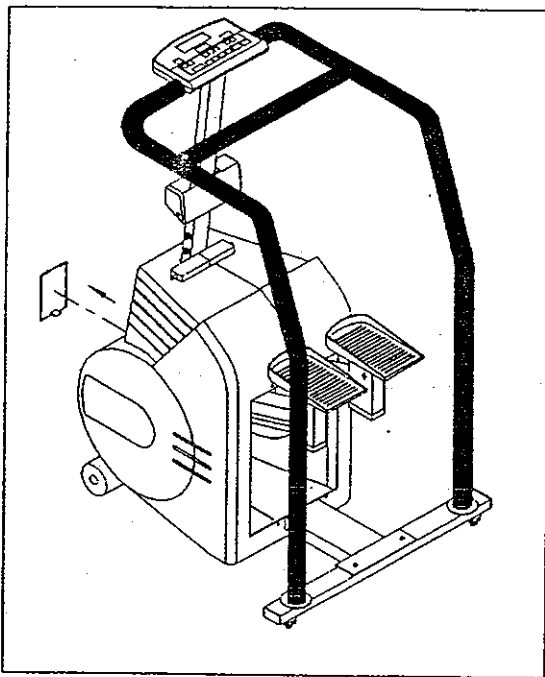

Fig 14. (7003)

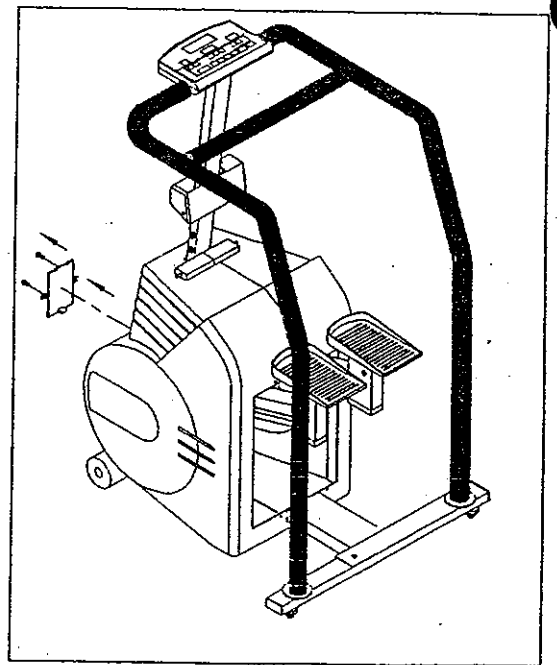

Fig 14. (7003/7003B/7003C/7003N)

5. Secure the front cover with the four screws (see Fig. 15).

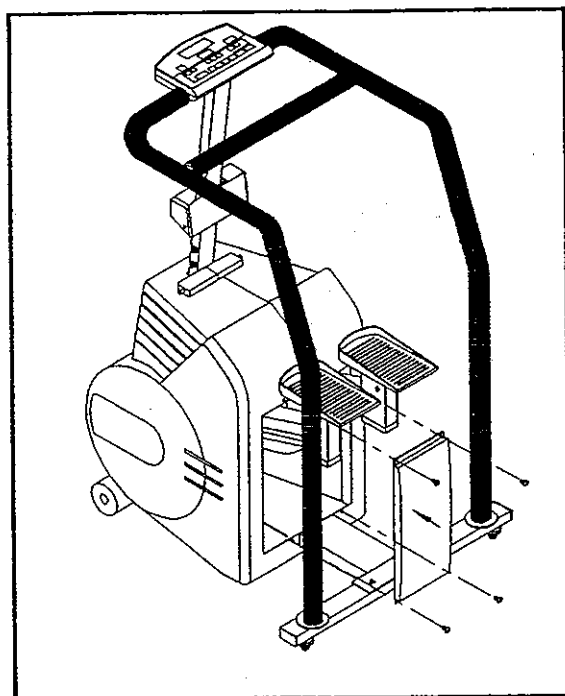

Fig. 15

6. Replace the transport wheels, tighten with screws and washers, then cover with labels (see Fig. 16).

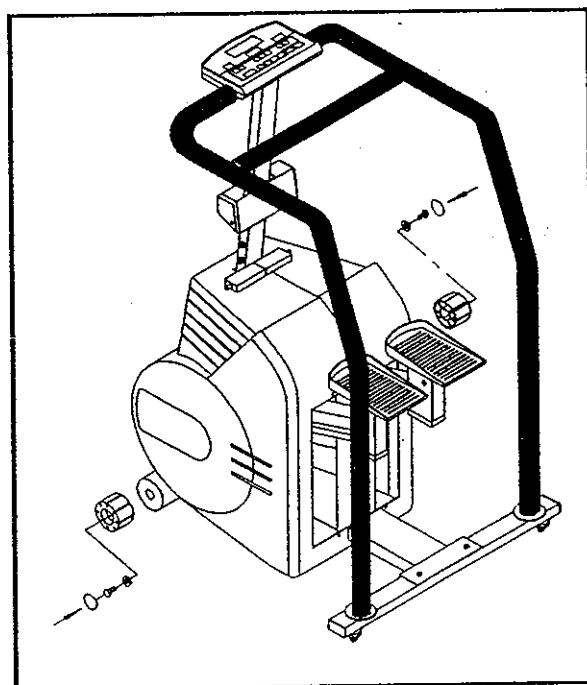

Fig. 16

7. Replace the post shroud, secure with two screws (see Fig. 17 & 18).

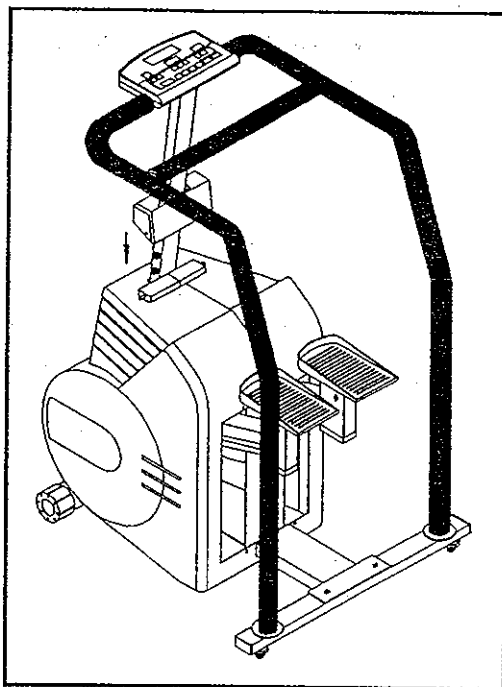

Fig. 17

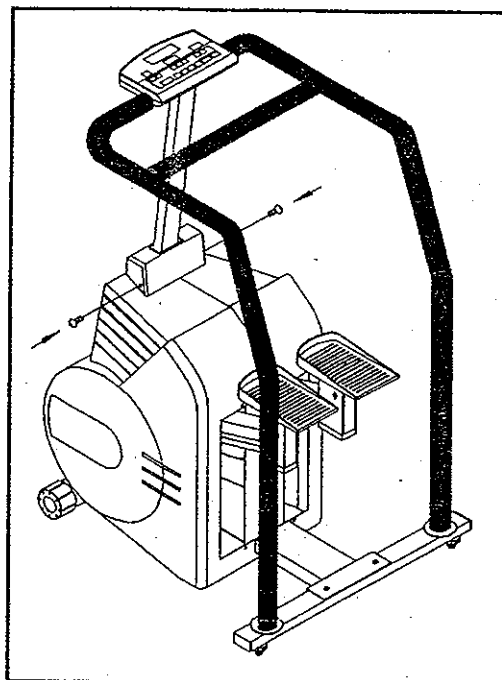

Fig. 18

R. ADAPTER REMOVAL AND INSTALLATION PROCEDURE

CAUTION: Make sure to turn the adapter switch to "O" (OFF) position, then unplug the power cord from the electrical outlet (see Fig. 1).

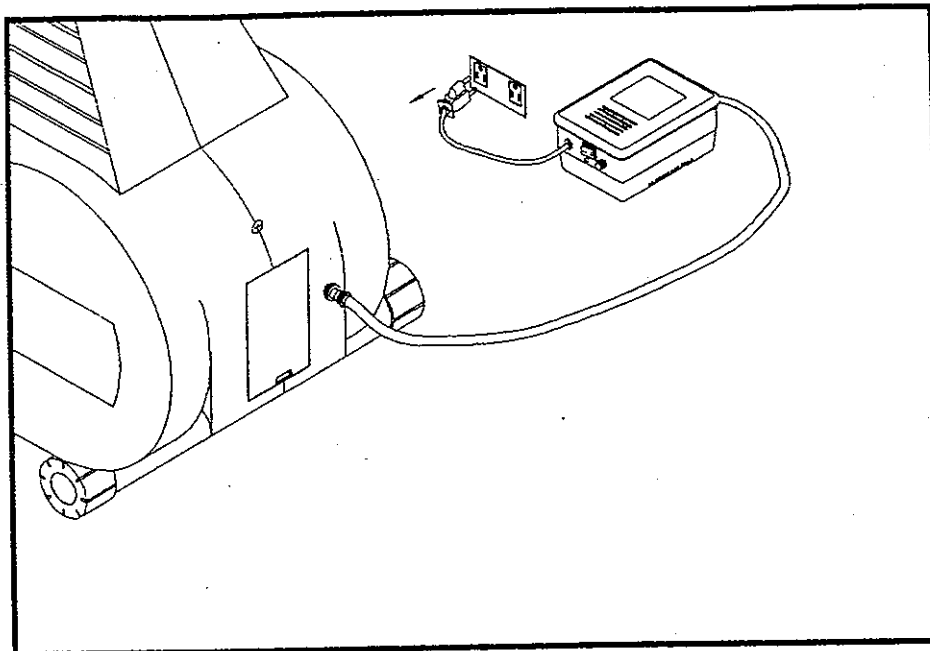

Fig.1

To remove the adapter connector, turn the knob counterclockwise. Unplug the adapter from the stair climber (see Fig. 2 to 2-2).

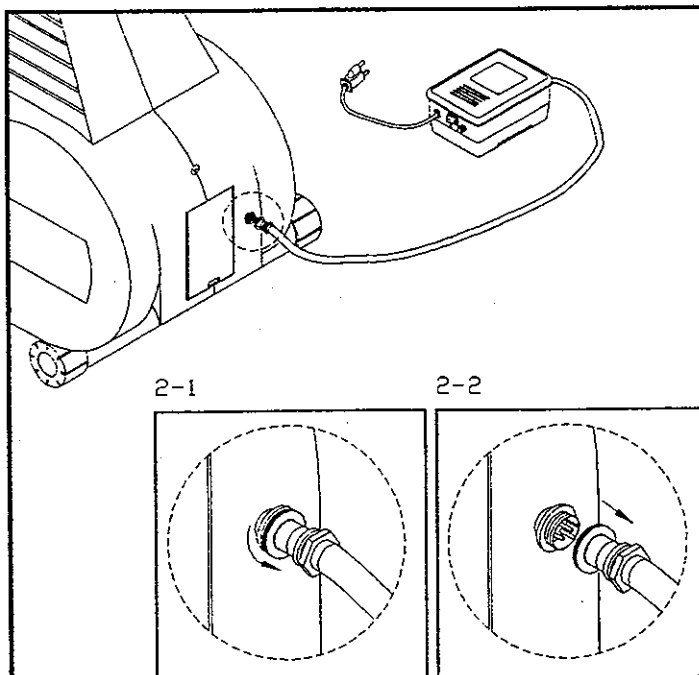

Fig. 2

To install:

Plug the new adapter's connector into the socket at the front of the stair climber.
Turn the holder clockwise to secure the adapter (see Fig. 3 to 3-2).

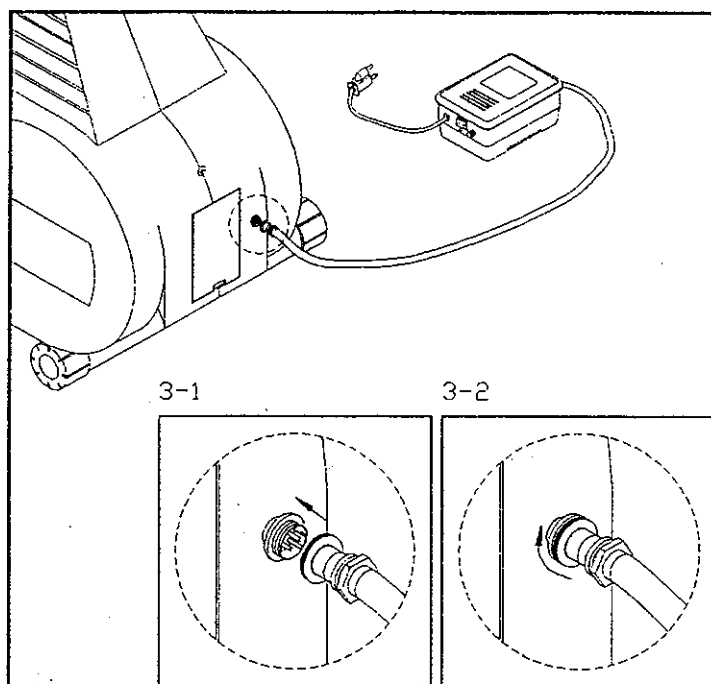

Fig. 3

The adapter connector is designed to engage in one direction only. Make sure it is securely in its socket to avoid damage to the stair climber.

S. ADAPTER FUSE REMOVAL AND INSTALLATION PROCEDURE

1. Locate the fuse holder (2 Amp) on the front of the adapter (see Fig. 1).

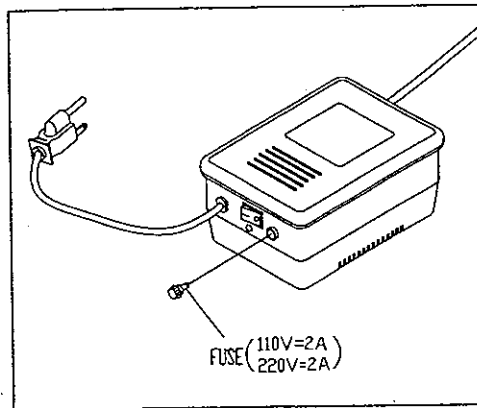

Fig. 1

2. Push the fuse holder in and then turn the holder counterclockwise to remove (see Fig. 2).

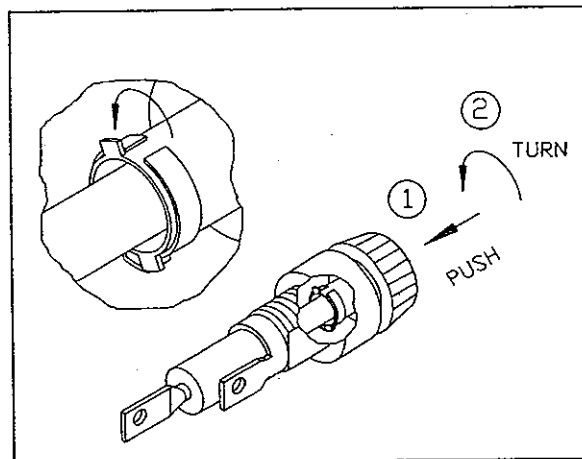

Fig. 2

3. Remove the damaged fuse (see Fig. 3).

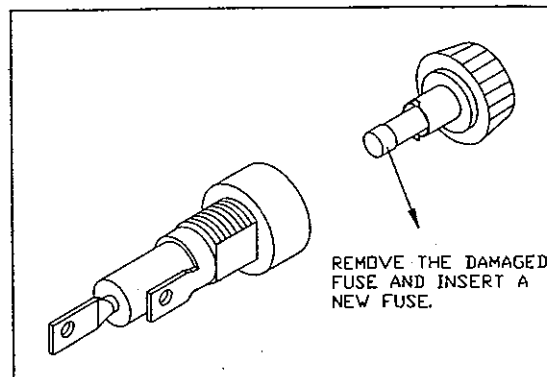

Fig. 3

To install:

Insert a new fuse into the holder: Push the fuse and holder in, then turn clockwise to secure the fuse holder (see Fig. 4).

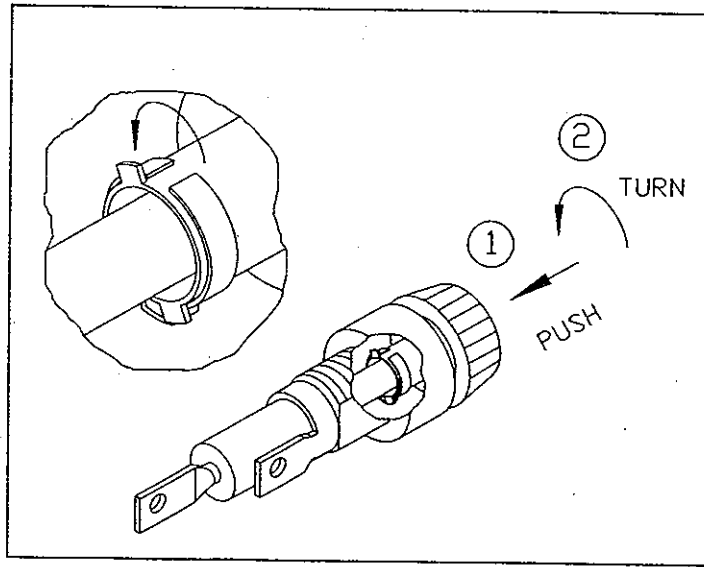

Fig. 4

T. TENSION/LOAD ADJUSTMENT (FOR 7003 & 7003B)

Under normal operation, the step speed of the stair climber in Level 1 should be between 25 step/min and 28 step/min.

NOTE 1. MAKE SURE TO INPUT THE EXACT WEIGHT OF USER BEFORE STEPPING ON THE STAIR CLIMBER.

NOTE 2. DO NOT HOLD THE HANDLEBAR WHEN STEPPING.

If the speed is not within this range, the VR unit needs to be adjusted.

1. Open the back cover (see Fig. 1). The VR can be found on the right hand side of the drive board.

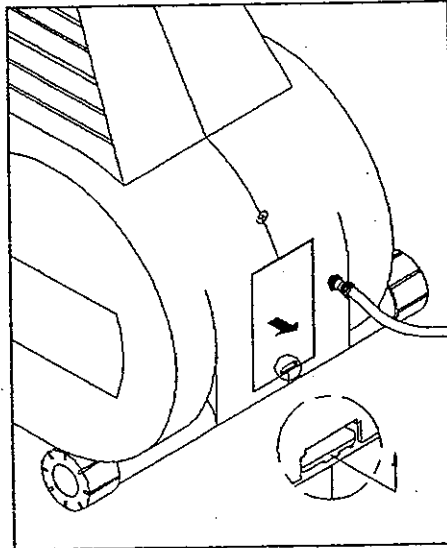

Fig.1

Please note that there are two kinds of VR units (distinguishable by a CE mark on the stair climber).

a) The VR with the CE mark (see Fig.2A) allows an adjustment of 1~2 turns per time.

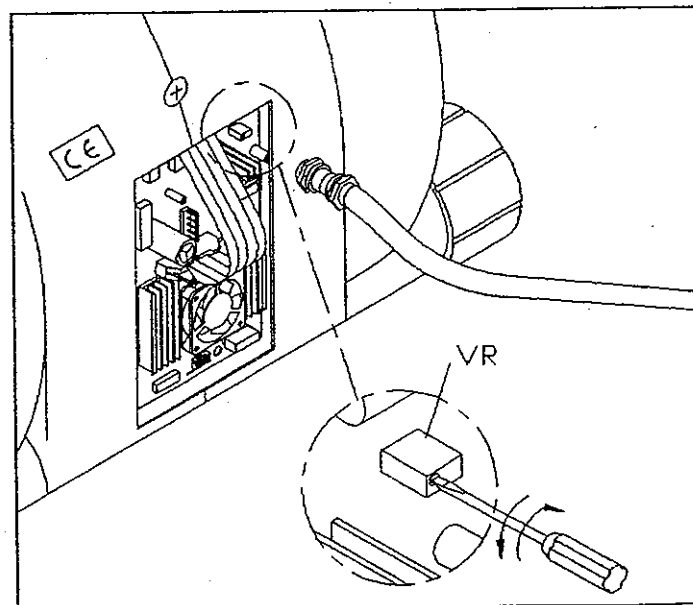

Fig. 2A

- b) The VR without the CE mark (see Fig. 2B) only allows an adjustment of 1~2 notches per time.

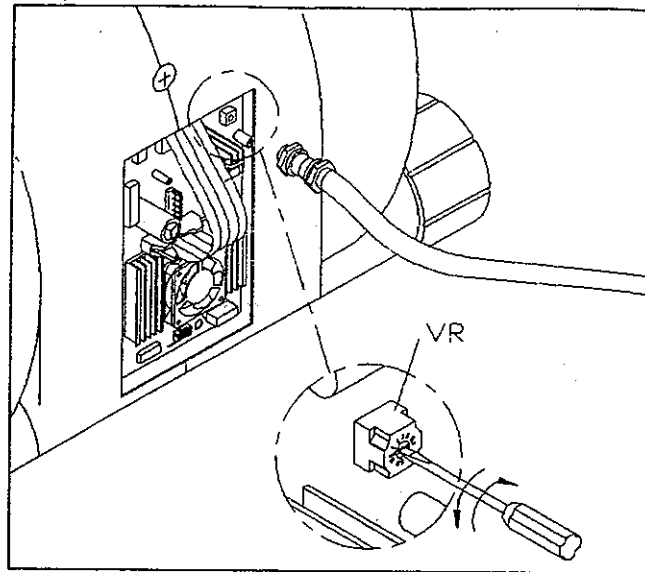

Fig. 2B

2. Turn on the stair climber and have someone stand on the stair climber footpads, input his/her weight, and select Level 1. Have this person begin to step without holding the handrails.
3. As the person steps on the stair climber, adjust the VR with a small screwdriver.

ATTENTION:

- . If the step/min is more than 28, turn the VR clockwise.
- . If the step/min is less than 25, turn the VR counterclockwise.

Adjust the VR unit until the step speed is between 25~28 step/min

4. Replace the back cover (see Fig. 3&4).

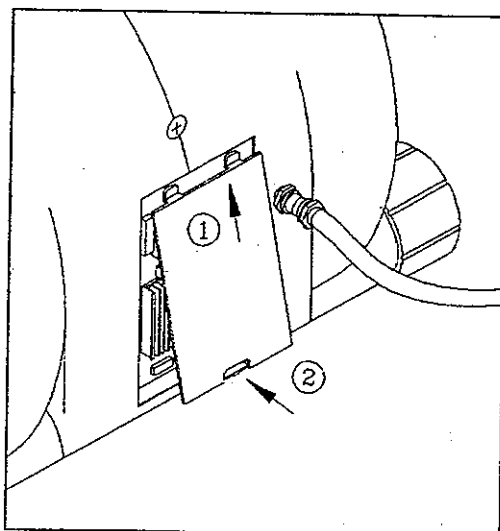

Fig.3

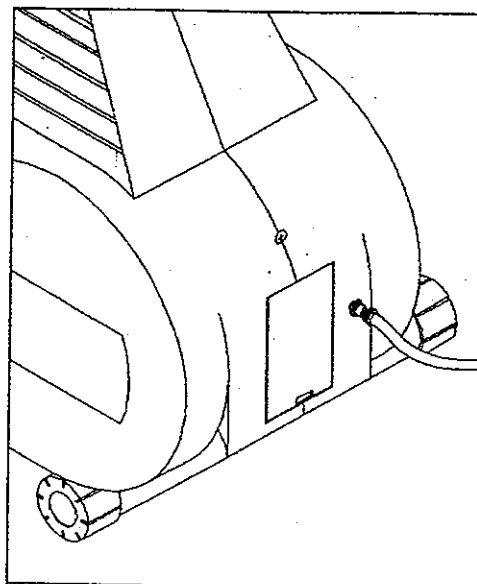

Fig. 4